

## Magnetically controlled liquid level indicator

Type: ITA

### Technical Catalogue

ITA with Aluminum-  
Indication rail  
and switch



ITA with mA-output signal and  
digital display with volume  
linearization



ITA with steam  
casing



ITA with Armaflex®-  
Isolation (refrigerant)



Inspection / Certificate:

1. Material certificate EN 10204 2.1
2. Material certificate EN 10204 3.1 B
3. Test acc. to NACE
4. Pressure test certificate
5. Pressure test acc to „AD-Merkblatt“ by German TUV
6. Construction and pressure test as per TRD by German TUV
7. Dye penetration test DIN 54152
8. X-Ray test acc. with DIN 54111, part 1
9. PMI-check
10. ATEX-certificate
11. General approval of construction inspection acc. with § 19 water resources law about flammable liquids-Vbf
12. Water level controller component-check as per VdTUV/WR91-352
13. Germanischer Lloyd
14. Certification of passivation
15. Weight certificate

ITA, material PVDF





**Headquarters:**  
**(Germany, world-wide sales)**  
INTRA-AUTOMATION GmbH  
Otto-Hahn-Strasse 20  
41515 Grevenbroich  
GERMANY

☎ +49-(0)2181-75665-0  
☎ +49-(0)2181-64492  
✉ [info@intra-automation.de](mailto:info@intra-automation.de)  
💻 [www.intra-automation.de](http://www.intra-automation.de)

**Subsidiary in the Netherlands:**  
**(Sales in the Benelux-States)**  
BV INTRA-AUTOMATION HTP  
Bosschendijk 193  
4731 DD Oudenbosch  
THE NETHERLANDS

☎ +31-(0)165-32201  
☎ +31-(0)165-322970  
✉ [info@intra-automation.nl](mailto:info@intra-automation.nl)  
💻 [www.intra-automation.nl](http://www.intra-automation.nl)

© 2008 by Intra-Automation GmbH  
ITA is a trade mark of Intra-Automation GmbH  
Please submit suggestions or comments regarding this ITA catalogue to:  
[info@intra-automation.de](mailto:info@intra-automation.de)

## List of contents:

1.	ISO-9001 Certificate	4
2.	Functioning and General Information	5
	2.1 Magnetically controlled liquid level gauge type ITA	5
	2.2 Level measurement tasks	5
	2.3 Advantages	6
	2.4 Switches and alarm contacts	6
	2.5 Floats	6
	2.6 Indication rails	7
	2.7 Materials	7
	2.8 Special versions	7
	2.9 Additional equipment	7
	2.10 Acceptance tests and certificates	7
3.	Level gauges in details	8
	3.1.1 ITA-3	8
	3.1.2 ITA-3.0	10
	3.2.1 ITA-3 Cryo (cryogenic applications)	18
	3.2.2 ITA-3.0 Cryo (cryogenic applications)	20
	3.3.1 ITA-3 CR64 (cryogenic applications)	27
	3.3.2 ITA-3.0 CR64 (cryogenic applications)	29
	3.4 ITA-3.5 (wetted parts E-CTFE-coated)	36
	3.5 ITA-3.8 (wetted parts E-TFE-coated, for vacuum service)	41
	3.6.1 ITA-4	46
	3.6.2 ITA-4.0	48
	3.7.1 ITA-4.1	52
	3.7.2 ITA-4.1.0	54
	3.8.1 ITA-5	58
	3.8.2 ITA-5.0	60
	3.9 ITA-5.5	65
	3.10.1 ITA-6	68
	3.10.2 ITA-6.0	70
	3.11.1 ITA-6 Cryo (cryogenic applications)	78
	3.11.2 ITA-6.0 Cryo (cryogenic applications)	80
	3.12.1 ITA-6 CR64 (cryogenic applications)	85
	3.12.2 ITA-6.0 CR64 (cryogenic applications)	87
	3.13 ITA-6.8 (wetted parts E-TFE-coated, for vacuum service)	92
	3.14.1 ITA-7	96
	3.14.2 ITA-7.0	98
	3.15.1 ITA-8.1 PVC	105
	3.15.2 ITA-8.2PP	109
	3.15.3 ITA-8.3 PVDF	113
	3.16.1 ITA-9.1 PVC	117
	3.16.2 ITA-9.2 PP	120
	3.16.3 ITA-9.3 PVDF	123
	3.17.1 ITA-10	126
	3.17.2 ITA-10.0	128
	3.18.1 ITA-11	135
	3.18.2 ITA-11.0	137
	3.19.1 ITA-12	144
	3.19.2 ITA-12.0	146
	3.20.1 ITA-13	153
	3.20.2 ITA-13.0	155

**List of contents (continuation):**

4.	Equipment	162
	4.1 ITA-3 Cryo; ITA-3.0 Cryo	162
	4.2 Armaflex®-insulation	163
	4.3 Heat insulation	164
	4.4 Technical data switches	165
	4.5 Contact NJ-EX	168
	4.6 Indication rails	169
	4.7 Digital indication with volume linearization	170
	4.8 Niveau-source	171
	4.9 Reed-contact	172
	4.10 Magnetostrictive level transmitter	173
	4.11 Transmitter	175
5.	Special constructions	194
	5.1 ITA-T1S	194
	5.2 ITA-T1R	198

**Ordering codes:**

For mag. level gauges

Behind each subchapter of chapter 3

For add. Equipment	186
For special designs	189
For spare parts	190
For documentation	199

## 1. ISO 9001 Certificate



# CERTIFICATE

The TÜV CERT Certification Body  
of TÜV Rheinland Industrie Service GmbH

certifies in accordance with  
TÜV CERT procedures that

**Intra-Automation GmbH**  
Otto-Hahn-Str. 20  
D - 41515 Grevenbroich

has established and applies a quality management system for

**Manufacturing, design and sale  
of measuring and control equipment**

An audit was performed, Report No. 036028.

Proof has been furnished that the requirements according to

**DIN EN ISO 9001:2000**

are fulfilled.

The certificate is valid until **2010-01-25**.

Certificate Registration No. **01 100 036028**



Cologne, 2007-03-20

First certification 2004

 **TÜVRheinland®**

  
TÜV CERT Certification Body of  
TÜV Rheinland Industrie Service  
GmbH

www.tuv.com

## 2. Functioning and General Information

### 2.1 Magnetically controlled liquid level gauge type ITA

The product line ITA is used wherever fluid level has to be monitored, indicated, and controlled in a reliable way, especially with corrosive, toxic and inflammable fluids.

The ITA level indicators offer a reliable, accident-free and maintenance-free usage, through a simple and break-resistant construction at a maximum process pressure of 320 bar and a temperature range from – 50 through 400 °C. The fluid level is indicated directly with a separation of the measurement and indication area. The magnetic transfer of the fluid level from the tank to the indicator is continuous and vibration-resistant, even in the case of fast changing levels.

It is possible to mount the indication rail in any position on the pipe diameter. There is no corrosion of the indication system. The ITA® instruments may be used in open or closed vessels. A definite level measurement without any power supply is guaranteed due to a continuous rotation of the wafers, even if a power loss in the plant occurs.

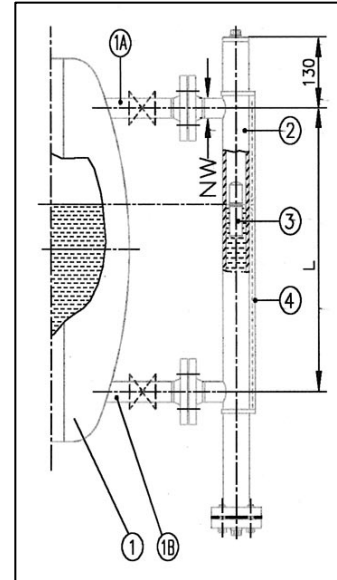

#### Functional principle:

A float chamber (2) is connected (1A and 1B) to the tank (1), and following the law of communicating tubes, the level in the float chamber is equal to the level of the tank. The float (3) follows the fluid level and transmits its movements contact-free to the indication rail (4) mounted on the outside. The float has a special magnet, which rotates the wafers by 180° as it passes them. The result is a clearly defined level indication, with the level shown in a continuous red stripe strongly contrasted to the white above. At increasing levels the color of the wafer changes from white to red and vice versa.

The indication rail and the wafers are made of Makrolon so that there will never be a problem of corrosion in humid and aggressive atmosphere. Each wafer has a permanent magnet, that is why the indicator is shock proof. Moreover, as there is no turbidness because of product contamination of the UV-radiation, the readability remains unobjectable even after some years.

All models are available with electronic alarms, that can be mounted at any position during operation of the system, which renders possible an optimal definition of the min. and max. data points. The indicator can be equipped with a scale for volume or height (depending on the customer's specifications).

### 2.2 Level measurement tasks

- 1.) Indicating the fluid level
- 2.) Monitoring the level with alarm contacts
- 3.) Transferring the level using measurement value sensors (analogue signal 4-20 mA) to electrical display units
- 4.) Interface level measurement

## 2.3 Advantages

No risk of glass breakage as a result of the separation of the measurement and indicator areas. The float principle means that changes of the density in the medium have very little influence on the indication accuracy.

## 2.4 Switches / Alarm contacts

Magnetic level indicators can be equipped with an arbitrary number of switch contacts. In contrast to electric float switches, switch contacts may be installed at any position of the stand pipe. Wherever additional float chambers are needed for float switches, magnetically controlled level gauges offer a considerable price benefit.

Electrical level measurement transducers which use the displacement principle must be recalibrated each time the fluid density has changed. The price of a magnetically controlled level indicator with integral electrical measurement transducer is considerably lower than level measurement transducers. The reed chain with an R/I measurement transducer can be changed without interrupting the operation. The measurement chamber is hermetically sealed – there is no contact between the fluid chamber and the reed chain.

The switches / alarm contacts are secured with pipe clips, and can be adjusted to any desired height. The connection is using 3-core cable or casing terminals. The changeover contact can be used as opener or closer. The switches are also available as explosion-proof version.

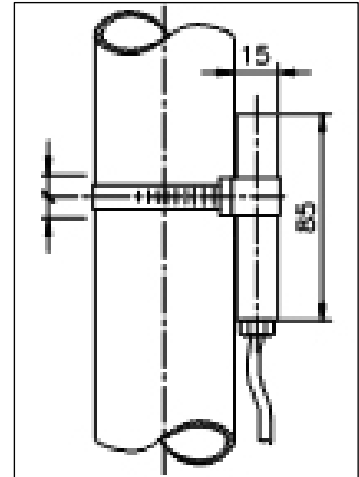

## 2.5 Floats

The construction of the float requires a great amount of technical knowledge. The float with its special magnet can rotate freely in the float chamber. The Intra construction avoids a guide wire and other devices. The float materials are stainless steel, 1.4571(316Ti), 1.4435 (316L) or titanium (PVC, PP, PVDF in case of the plastics level gauges). Floats without gas-prestressing are used from a minimum density of 0,35 kg/dm<sup>3</sup>. The maximum process pressure for sealed floats is 250 bar; at higher pressures the floats must be relieved from pressure (not to be used for condensing media).

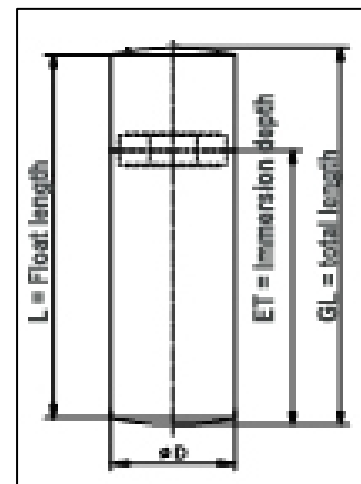

## 2.6 Indication rail

The ITA level gauges can be supplied with indication rails made from 2 different materials. Makrolon indication rails are resistible to breakage. The max. permissible media temperature is 120°C, with 20°C ambient temperature and natural convection as test conditions. The rails are resistible to UV-radiation and aggressive atmospheres and are sealed against dust by two seal-caps. Aluminum indication rails can be supplied as one part rail up to a length of 6 m. The sight cover material depends on the temperature, up to 150°C the material is Makrolon and up to 400°C it is glass. The surface of the indication rail can be coated with Saekaphen if required, the standard surface is brown-anodized.

## 2.7 Materials

The gauge chamber and the floats are made of stainless steel (1.4571), 254SMO (1.4529), titanium, Hasteloy, PVC, PP, PVDF and PTFE. Other materials on request.

## 2.8 Special versions

1. Transmitter, output signal 0-20 or 4-20 mA
2. Steam jacket, e.g. for viscous media
3. Float chamber with Armaflex® insulation, for temperatures below zero (centigrade)
4. Scale made of Gravoloy (white plastics) or aluminium red anodized
5. Two-parts versions without interruption of the indication, for measuring lengths > 5 m
6. Works report DIN 50049
7. Level indicator in GL-design (Germanischer Lloyd, Bureau Veritas, Det Norske Veritas, Lloyd's Register)
8. Usage as an overfilling guard for tanks for storing inflammable and non-inflammable water polluting liquids.
9. ITA Cryogenic versions for refrigerants
10. ITA with lining made of PTFE
11. ITA with inside coating made of E-CTFE (Halar)

## 2.9 Additional equipment

1. Anti-freezing heating belt for use in the open air
2. Vent/drain valves, threaded or flanged connection
3. Measuring scale, divisions to client's specifications
4. Armaflex insulation
5. Protective hose, additional protection of the indicator against dust, dirt and moisture
6. Plastics-indicator with armoring

## 2.10 Inspection / Certificates

1. Material certificate EN 10204 2.1
2. Material certificate EN 10204 2.2
3. Material certificate EN 10204 3.1 A/B/C
4. Test according to NACE
5. Pressure test certificate
6. Pressure test according to "AD-Merkblatt" by the German TÜV
7. Construction and pressure test as per TRD by the TÜV
8. Dye penetration test DIN 54152
9. X-ray-test in accordance with DIN 54111 part 1
10. PMI-check
11. ATEX-certification
12. General approval of construction inspection in accordance with § 19 water resources law – WHG – and § 12 law about flammable liquids – VbF
13. Water level controller component check as per VdTÜV/WR91-352
14. Germanischer Lloyd
15. Certificate of passivation
16. Weight certificate
17. PED 97/23/EG



### 3 Level Gauges in details

#### 3.1.1 ITA-3

Characteristics: **PN16 / Float pipe and flange material 1.4404**

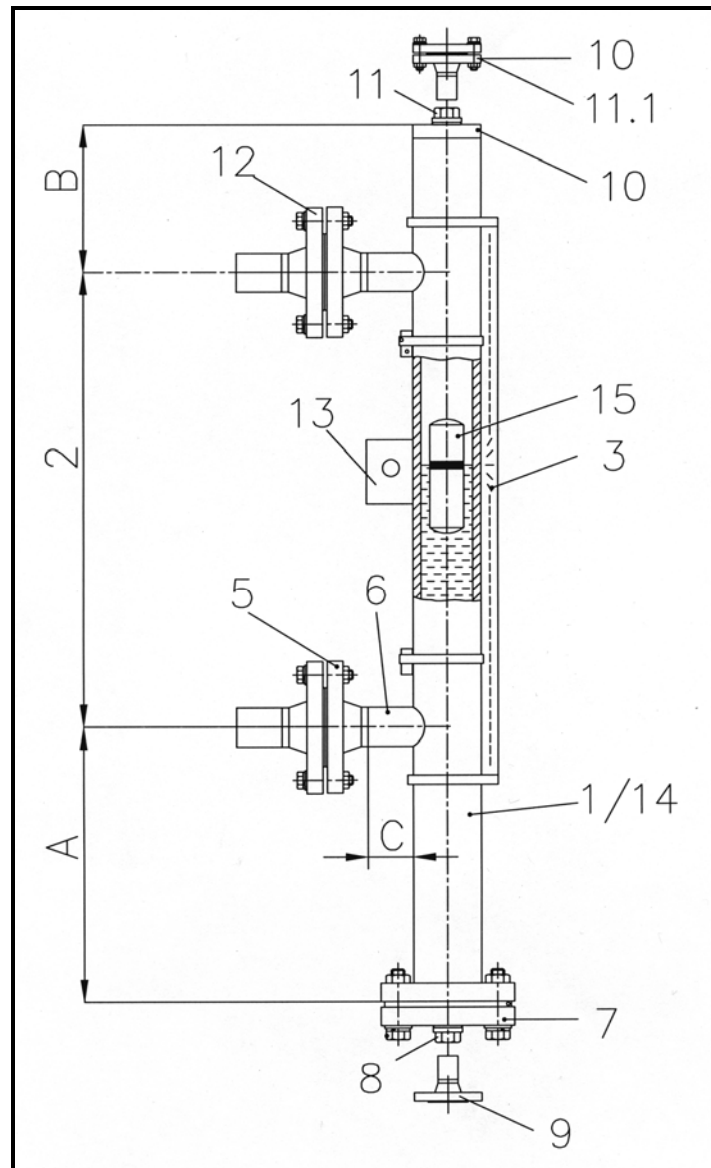

Parts drawing ITA-3

**Key:**

- |   |   |    |                               |
|---|---|----|-------------------------------|
| 1 | Float pipe welded Dimensions 60,3 x 2 mm                | 9  | Additional drain flange, open |
| 2 | c to c distance   | 10 | Float pipe top end finish     |
| 3 | Design (indication rail)                                | 11 | Vent plug                     |
| 5 | Process connection side/side                            | 12 | Counter flanges               |
| 6 | Side studs welded with T-pieces for 100 % X-ray testing | 13 | Additional bracket            |
| 7 | Float removal flange                                    | 14 | Float pipe seamless           |
| 8 | Drain plug  | 15 | Float                         |

**Technical specifications magnetic level gauge type ITA 3**

Principle	:	Communicating tubes with magnetic float
Mounting position	:	vertical
Measuring range	:	<b>max. 5000 mm (one-part)</b> > 5000 mm 2- or multipart
Pipe diameter	:	<b>60,3 x 2 mm welded,</b> 60,3 x 2 mm seamless 2"Sch10 <b>necking connection</b> or buttweld with T-pieces
Process connection	:	to specify: <b>Flanges DN15-50 (1/2"-2"150#),</b> <b>Welding or threaded stud</b>
Drain/vent connections	:	<b>Plug R1/2"</b> (for more please see price list)
Pipe material	:	<b>1.4404</b> , 1.4435, 1.4539, Hastelloy C4 (2.4610), Inconel 625 (2.4856), Inconel 825 (2.4858), Titan (3.7035) Other materials also possible (on request)
Flange material	:	same as pipe material
Float material	:	<b>1.4404</b> Titan, Titan/E-CTFE-coated
Operation temperature	:	-50...+400 °C
Operation pressure	:	max. 16 bar
Operation density	:	min. 0,3761 kg/dm <sup>3</sup>
Bolts & Nuts	:	<b>CS</b> SS
Gasket	:	<b>PTFE up to 100 °C</b> <b>Klingersil C4400 up to 175 °C</b> <b>Graphit spiral wound up to 400 °C**</b>
Indication rail	:	<b>Makrolon up to 120 °C</b> Aluminium up to 400 °C 1.4301 up to 400 °C
Float types	:	Cylindrical, sealed type Length: - <b>270 mm</b> - 130 mm - 150 mm - 210 mm - 330 mm - 430 mm - 530 mm - 630 mm
Standard dimensions	:	- A = 240* - B = 130 - C = 40

**Base equipment printed in bold letters!**

\* for densities < 0,7374 kg/dm<sup>3</sup> enlarge the scale A

\*\* only with vent- and/or drain-flanges DN50 resp. 2"

### 3.1.2 ITA-3.0

Characteristics: **PN16 / Float pipe: 1.4404; Flanges: CS**

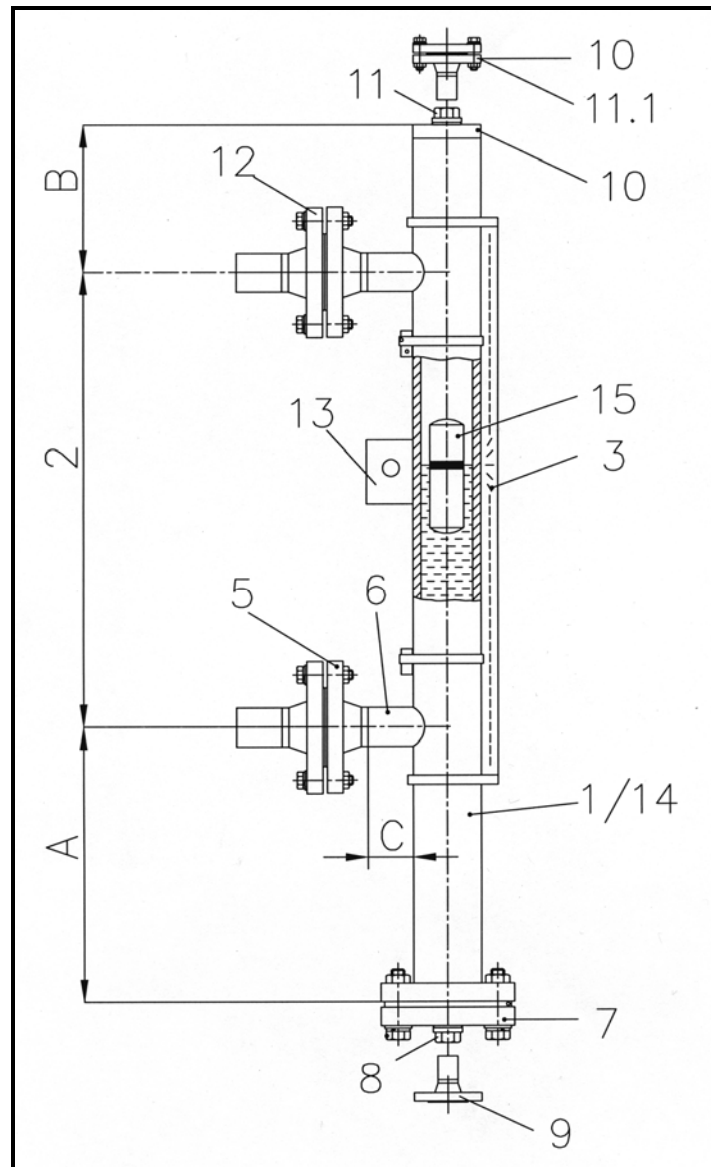

Parts drawing ITA-3.0

**Key:**

- |   |   |    |                               |
|---|---|----|-------------------------------|
| 1 | Float pipe welded Dimensions 60,3 x 2 mm                | 9  | Additional drain flange, open |
| 2 | c to c distance   | 10 | Float pipe top end finish     |
| 3 | Design (indication rail)                                | 11 | Vent plug                     |
| 5 | Process connection side/side                            | 12 | Counter flanges               |
| 6 | Side studs welded with T-pieces for 100 % X-ray testing | 13 | Additional bracket            |
| 7 | Float removal flange                                    | 14 | Float pipe seamless           |
| 8 | Drain plug  | 15 | Float                         |

**Technical specifications magnetic level gauge type ITA 3.0**

Principle	:	Communicating tubes with magnetic float
Mounting position	:	vertical
Measuring range	:	<b>max. 5000 mm (one-part)</b> > 5000 mm 2- or multipart
Pipe diameter	:	<b>60,3 x 2 mm welded,</b> 60,3 x 2 mm seamless 2"Sch10 <b>necking connection</b> or buttweld with T-pieces
Process connection	:	to specify: <b>Flanges DN15-50 (1/2"-2"150#),</b> <b>Welding or threaded stud</b>
Drain/vent connections	:	<b>Plug R1/2"</b> (for more please see price list)
Pipe material	:	<b>1.4404</b> , 1.4435, 1.4539, Hastelloy C4 (2.4610), Inconel 625 (2.4856), Inconel 825 (2.4858), Titan (3.7035) Other materials also possible (on request)
Flange material	:	Carbon steel
Float material	:	<b>1.4404</b> Titan, Titan/E-CTFE-coated
Operation temperature	:	-50...+400 °C
Operation pressure	:	max. 16 bar
Operation density	:	min. 0,3761 kg/dm <sup>3</sup>
Bolts & Nuts	:	<b>CS</b> SS
Gasket	:	<b>PTFE up to 100 °C</b> <b>Klingersil C4400 up to 175 °C</b> <b>Graphit spiral wound up to 400 °C**</b>
Indication rail	:	<b>Makrolon up to 120 °C</b> Aluminium up to 400 °C 1.4301 up to 400 °C
Float types	:	Cylindrical, sealed type Length: - <b>270 mm</b> - 130 mm - 150 mm - 210 mm - 330 mm - 430 mm - 530 mm - 630 mm
Standard dimensions	:	- A = 240* - B = 130 - C = 40

**Base equipment printed in bold letters!**

\* for densities < 0,7374 kg/dm<sup>3</sup> enlarge the scale A

\*\* only with vent- and/or drain-flanges DN50 resp. 2"

<b>Order codes for magnetic level gauge type ITA-3 and ITA-3.0</b>
--

Code	Description
<b>ITA-3 ITA-3.0</b>	<b>1. Float pipe welded Dimensions 60,3 x 2 mm</b>
	<b>2. c to c distance</b>
<b>L</b>	c to c distance in mm
	<b>3. Design</b>
<b>0</b>	without indication rail
<b>1</b>	Indication rail material: Makrolon max. 120 °C
<b>2</b>	Indication rail material: Aluminium max. 400 °C
<b>3</b>	Indication rail material: 1.4401 max. 400 °C
	<b>4. c to c distance &lt; 5000 mm</b>
<b>A</b>	< 5000 mm - without flange connection; DN 32 PN 16
<b>B</b>	> 5000 mm - with flange connection; DN 32 PN 16
	<b>5. Process connection side/side</b>
<b>Y</b>	Welding connection (please specify)
<b>Z</b>	Threaded connection (please specify)
<b>1</b>	Flanges DN 15 PN 16
<b>2</b>	Flanges DN 20 PN 16
<b>3</b>	Flanges DN 25 PN 16
<b>4</b>	Flanges DN 32 PN 16
<b>5</b>	Flanges DN 40 PN 16
<b>6</b>	Flanges DN 50 PN 16
<b>A</b>	Flanges 1/2" ANSI 150 lbs
<b>B</b>	Flanges 3/4" ANSI 150 lbs
<b>C</b>	Flanges 1" ANSI 150 lbs
<b>D</b>	Flanges 1 1/4" ANSI 150 lbs
<b>E</b>	Flanges 1 1/2" ANSI 150 lbs
<b>F</b>	Flanges 2" ANSI 150 lbs
	<b>5.1 Surface side flanges</b>
<b>0</b>	without
<b>A</b>	Standard- Surface Form C
<b>B</b>	Standard-Surface RF
<b>C</b>	Surface Form D Rz=40
<b>D</b>	Surface Form E Rz=16
<b>E</b>	Surface RFSF (smooth finished)
<b>F</b>	Surface Nut (DIN2512)
<b>G</b>	Surface groove large
<b>H</b>	Surface Feder (DIN2512)
<b>K</b>	Surface tongue-large
<b>L</b>	Surface RTJ (ANSI) 1/2" bis 2"
	<b>6. Side studs welded with T-pieces for 100 % X-ray testing</b>
<b>0</b>	without
<b>T</b>	T-pieces

**Order codes for magnetic level gauge type ITA-3 and ITA-3.0 (Continuation)**

Code	Description
<b>7. Float removal flange (bottom side)</b>	
1	End cap (only if float removal flange (top side))
2	Flange DN 32 PN 16 incl. blind flange
3	Flange DN 50 PN 16 incl. blind flange
A	Flange 2" ANSI 150 lbs incl. blind flange
B	Flange DN 50 PN 16 reinforced for shut off valve on side
C	Flange 2" ANSI 150 lbs reinforced for shut off valve on side
<b>7.1 Surface float removal flange (bottom side) (only DN50 or 2")</b>	
0	without (Float removal flange (bottom side) = end cap or < DN50 or 2")
A	Standard- Surface Form C
B	Standard-Surface RF
C	Surface Form D Rz=40
D	Surface Form E Rz=16
E	Surface RFSF (smooth finished)
F	Surface groove (DIN2512)
G	Surface groove large
H	Surface tongue (DIN2512)
K	Surface tongue-large
L	Surface RTJ (ANSI) 1/2" bis 2"
<b>7.2 Bolts &amp; nuts float removal flange (bottom side)</b>	
0	without (Float removal flange (bottom side) = end cap)
1	M16 x 65 mm; mat. zincd steel; flange DN 32 PN 16
2	M16 x 65 mm; mat. stainless steel 1.4301; flange DN 32 PN 16
3	M16 x 65 mm; mat. zincd steel; flange DN 50 PN 16
4	M16 x 65 mm; mat. stainless steel 1.4301; flange DN 50 PN 16
A	5/8" x 83; mat. zincd steel A193B7; fange 2" ANSI 150 lbs
B	5/8" x 83; mat. stainless steel A193B8 A1948M; flange 2" ANSI 150 lbs
C	Bolts & nuts PTFE coated (only DN 50 or 2")
<b>8. Drain plug</b>	
0	without
1	Drain plug G 1/2" with soft iron gasket
2	Drain plug 1/2" NPT
3	Drain plug 3/4" NPT
4	Drain plug 1" NPT
<b>9. Additional drain flange, open</b>	
0	without
1	Drain stud with flange DN 15 PN 16
2	Drain stud with flange DN 20 PN 16
3	Drain stud with flange DN 25 PN 16
4	Drain stud with flange DN 32 PN 16
5	Drain stud with flange DN 40 PN 16
A	Drain stud with flange 1/2" ANSI 150 lbs
B	Drain stud with flange 3/4" ANSI 150 lbs
C	Drain stud with flange 1" ANSI 150 lbs
D	Drain stud with flange 1 1/4" ANSI 150 lbs
E	Drain stud with flange 1 1/2" ANSI 150 lbs

**Order codes for magnetic level gauge type ITA-3 and ITA-3.0 (Continuation)**

Code	Description
<b>9.1 Drain flange with concentric reducer (X-ray testing)</b>	
0	without
1	DN 15 PN 16
2	DN 20 PN 16
3	DN 25 PN 16
4	DN 32 PN 16
5	DN 40 PN 16
A	1/2" ANSI 150 lbs
B	3/4" ANSI 150 lbs
C	1" ANSI 150 lbs
D	1 1/4" ANSI 150 lbs
E	1 1/2" ANSI 150 lbs
<b>9.2 Surface open drain flange</b>	
0	without (additional drain flange = without)
B	Standard-Surface RF
C	Surface Form D Rz=40
D	Surface Form E Rz=16
E	Surface RFSF (smooth finished)
F	Surface groove (DIN2512)
G	Surface groove large
H	Surface tongue (DIN2512)
K	Surface tongue-large
L	Surface RTJ (ANSI) 1/2" bis 2"
<b>10. Float pipe top end finish</b>	
1	End cap
2	Flange with blind flange DN 32 PN 16
3	Flange with blind flange DN 50 PN 16
A	Flange with blind flange 2" ANSI 150 lbs
<b>10.1 Surface float pipe top end finish flange (only DN50 or 2")</b>	
0	without (Float pipe top end finish = End cap or < DN50 or 2")
A	Standard- Surface Form C
B	Standard-Surface RF
C	Surface Form D Rz=40
D	Surface Form E Rz=16
E	Surface RFSF (smooth finished)
F	Surface groove (DIN2512)
G	Surface groove large
H	Surface tongue (DIN2512)
K	Surface tongue-large
L	Surface RTJ (ANSI) 1/2" bis 2"

**Order codes for magnetic level gauge type ITA-3 and ITA-3.0 (Continuation)**

Code	Description
<b>10.2 Bolts &amp; nuts float pipe top end finish flange (only DN50 or 2")</b>	
0	without (Float removal flange (bottom side) = end cap)
1	M16 x 65 mm; mat. zincd steel; flange DN 32 PN 16
2	M16 x 65 mm; mat. stainless steel 1.4301; flange DN 32 PN 16
3	M16 x 65 mm; mat. zincd steel; flange DN 50 PN 16
4	M16 x 65 mm; mat. stainless steel 1.4301; flange DN 50 PN 16
A	5/8" x 83; mat. zincd steel A193B7; fange 2" ANSI 150 lbs
B	5/8" x 83; mat. stainless steel A193B8 A1948M; flange 2" ANSI 150 lbs
C	Bolts & nuts PTFE coated (only DN 50 or 2")
<b>11. Vent plug at top end</b>	
0	without
1	Vent plug G 1/2" with soft iron gasket
2	Vent plug 1/2" NPT
3	Vent plug 3/4" NPT
4	Vent plug 1" NPT
<b>11.1 Vent flange welded to end cap instead of vent plug</b>	
0	without
1	Flanged DN 15 PN 16 (socket weld construction to endcap)
2	Flanged DN 20 PN 16 (socket weld construction to endcap)
3	Flanged DN 25 PN 16 (socket weld construction to endcap)
4	Flanged DN 32 PN 16 (socket weld construction to endcap)
5	Flanged DN 40 PN 16 (socket weld construction to endcap)
6	Flanged DN 50 PN 16 (socket weld construction to endcap)
A	Flanged 1/2" ANSI 150 lbs (socket weld construction to endcap)
B	Flanged 3/4" ANSI 150 lbs (socket weld construction to endcap)
C	Flanged 1" ANSI 150 lbs (socket weld construction to endcap)
D	Flanged 1 1/4" ANSI 150 lbs (socket weld construction to endcap)
E	Flanged 1 1/2" ANSI 150 lbs (socket weld construction to endcap)
<b>11.2 Vent flange with concentric reducer (X-ray testing)</b>	
0	without
1	DN 15 PN 16
2	DN 20 PN 16
3	DN 25 PN 16
4	DN 32 PN 16
5	DN 40 PN 16
A	1/2" ANSI 150 lbs
B	3/4" ANSI 150 lbs
C	1" ANSI 150 lbs
D	1 1/4" ANSI 150 lbs
E	1 1/2" ANSI 150 lbs



**Order codes for magnetic level gauge type ITA-3 and ITA-3.0 (Continuation)**

Code	Description
<b>11.3 Surface vent flange welded to end cap (only DN50 or 2")</b>	
0	without (Vent flange welded to end cap = without)
A	Standard- Surface Form C
B	Standard-Surface RF
C	Surface Form D Rz=40
D	Surface Form E Rz=16
E	Surface RFSF (smooth finished)
F	Surface groove (DIN2512)
G	Surface groove large
H	Surface tongue (DIN2512)
K	Surface tongue-large
L	Surface RTJ (ANSI) 1/2" bis 2"
<b>12. Counter flanges</b>	
0	without
1	DN 15 PN 16
2	DN 20 PN 16
3	DN 25 PN 16
4	DN 32 PN 16
5	DN 40 PN 16
6	DN 50 PN 16
A	1/2" 150 lbs
B	3/4" 150 lbs
C	1" 150 lbs
D	1 1/4" 150 lbs
E	1 1/2" 150 lbs
F	2" 150 lbs
<b>12.1 Surface counter flanges</b>	
0	without (Counter flanges = without)
A	Standard- Surface Form C
B	Standard-Surface RF
C	Surface Form D Rz=40
D	Surface Form E Rz=16
E	Surface RFSF (smooth finished)
F	Surface groove (DIN2512)
G	Surface groove large
H	Surface tongue (DIN2512)
K	Surface tongue-large
L	Surface RTJ (ANSI) 1/2" bis 2"
<b>12.2 Bolts &amp; Nuts counter flanges</b>	
0	without (Counter flanges = without)
1	M16 x 65 mm; mat. zincd steel; flange DN 32 PN 16
2	M16 x 65 mm; mat. stainless steel 1.4301; flange DN 32 PN 16
3	M16 x 65 mm; mat. zincd steel; flange DN 50 PN 16
4	M16 x 65 mm; mat. stainless steel 1.4301; flange DN 50 PN 16
A	5/8" x 83; mat. zincd steel A193B7; flange 2" ANSI 150 lbs
B	5/8" x 83; mat. stainless steel A193B8 A1948M; flange 2" ANSI 150 lbs
Z	Bolts & nuts PTFE coated (only DN 50 or 2")

**Order codes for magnetic level gauge type ITA-3 and ITA-3.0 (Continuation)**

Code	Description
<b>13. Additional bracket welded to the float pipe</b>	
0	without
H	Bracket
<b>14. Float pipe seamless</b>	
0	without
S	60,3 x 2 mm seamless
<b>15. Float</b>	
D8C0VY	52 x 240; material: 1.4404; pressure max. 16 bar min. density of fluid: 0,7374 kg/dm <sup>3</sup>
F7C2VY	50,8 x 270; material: Titanium*; pressure max. 16 bar min. density of fluid: 0,5723 kg/dm <sup>3</sup>
B8C1SY	52 x 150; material: 1.4571; pressure max. 16 bar; min. density of fluid: 1,2346 kg/dm <sup>3</sup> ; sealed
B7C2SY	50,8 x 150; material: Titanium*; pressure max. 16 bar; min. density of fluid: 0,9646 kg/dm <sup>3</sup> ; sealed
G7C2SY	50,8 x 330; material: Titanium*; pressure max. 16 bar; min. density of fluid: 0,4955 kg/dm <sup>3</sup> ; sealed
H7C2SY	50,8 x 430; material: Titanium*; pressure max. 16 bar; min. density of fluid: 0,4358 kg/dm <sup>3</sup> ; sealed
K7C2SY	50,8 x 530; material: Titanium*; pressure max. 16 bar; min. density of fluid: 0,4017 kg/dm <sup>3</sup> ; sealed
L7C2SY	50,8 x 630; material: Titanium*; pressure max. 16 bar; min. density of fluid: 0,3761 kg/dm <sup>3</sup> ; sealed
F8C3VY	52 x 270; material: Titanium / E-CTFE (Halar®); pressure max. 16 bar; min. density of fluid: 0,6873 kg/dm <sup>3</sup> ; sealed
F8C5VY	52 x 270; material: Hastelloy C4; pressure max. 16 bar; min. density of fluid: 0,7510 kg/dm <sup>3</sup> ; sealed

1	2	3	4	5	6	7	8	9	10	11	12	13	14	15	
ITA-3	L= cm														Y

1	2	3	4	5	6	7	8	9	10	11	12	13	14	15	
ITA-3.0	L= cm														Y

### 3.2.1 ITA-3 Cryo (cryogenic applications)

Characteristics: PN16 / Float pipe and flange material 1.4404

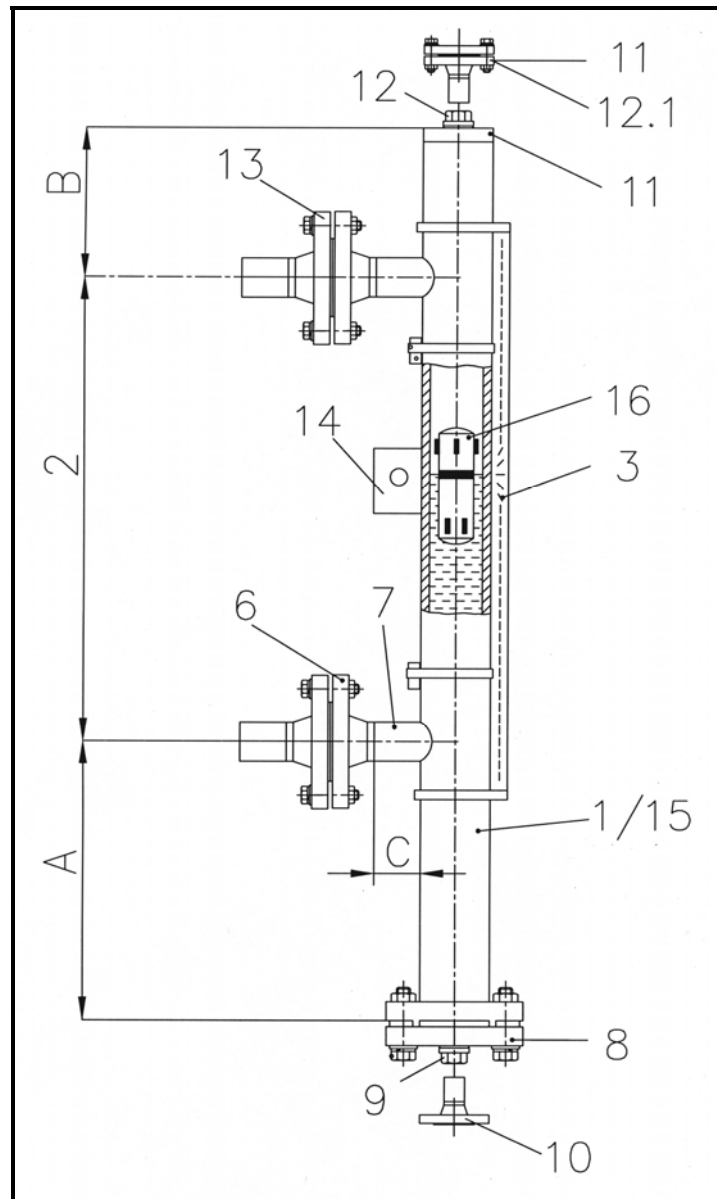

Parts drawing ITA-3 Cryo

**Key:**

- |   |  |    |                               |
|---|--|----|-------------------------------|
| 1 | Float pipe welded Dimensions 60,3 x 2 mm                   | 9  | Drain plug                    |
| 2 | c to c distance  | 10 | Additional drain flange, open |
| 3 | Design (indication rail)                                   | 11 | Float pipe top end finish     |
| 4 | Armaflex insulation  | 12 | Vent plug                     |
| 6 | Process connection side/side                               | 13 | Counter flanges               |
| 7 | Side studs welded with T-pieces for 100 %<br>X-ray testing | 14 | Additional bracket            |
| 8 | Float removal flange                                       | 15 | Float pipe seamless           |
|   |  | 16 | Float                         |

<b>Technical specifications magnetic level gauge type ITA 3 Cryo</b>
--

Principle	:	Communicating tubes with magnetic float
Mounting position	:	vertical
Measuring range	:	<b>max. 5000 mm (one-part)</b> > 5000 mm 2- or multipart
Pipe diameter	:	<b>60,3 x 2 mm welded,</b>
Process connection	:	to specify: <b>Flanges DN15-50 (1/2"-2"150#),</b> <b>Welding or threaded stud</b>
Drain/vent connections	:	<b>Plug G1/2"</b>
Pipe material	:	<b>1.4404</b> , 1.4435, 1.4539, Hastelloy C4 (2.4610), Inconel 625 (2.4856), Inconel 825 (2.4858), Titan (3.7035) Other materials also possible (on request)
Flange material	:	same as pipe material
Float material	:	<b>1.4404</b> Titanium, Titanium/E-CTFE-coated
Operation temperature	:	-200...+100 °C
Operation pressure	:	max. 16 bar
Operation density	:	min. 0,4017 kg/dm <sup>3</sup>
Bolts & Nuts	:	<b>CS</b> (min. -10 °C) SS or material in acc. with DIN 17280
Gasket	:	<b>PTFE min. -150 °C</b> <b>Klingersil TOP Chem 2000</b>
Indication rail	:	<b>Aluminium</b> 1.4301
Float types	:	Cylindrical, sealed type Length: - <b>270 mm*</b>

**Base equipment printed in bold letters!**

**\* not for vaporizing media (e.g. ammonia)**

**3.2.2 ITA-3.0 Cryo (cryogenic applications)**

Characteristics: PN16 / Float pipe: 1.4404; Flanges: CS

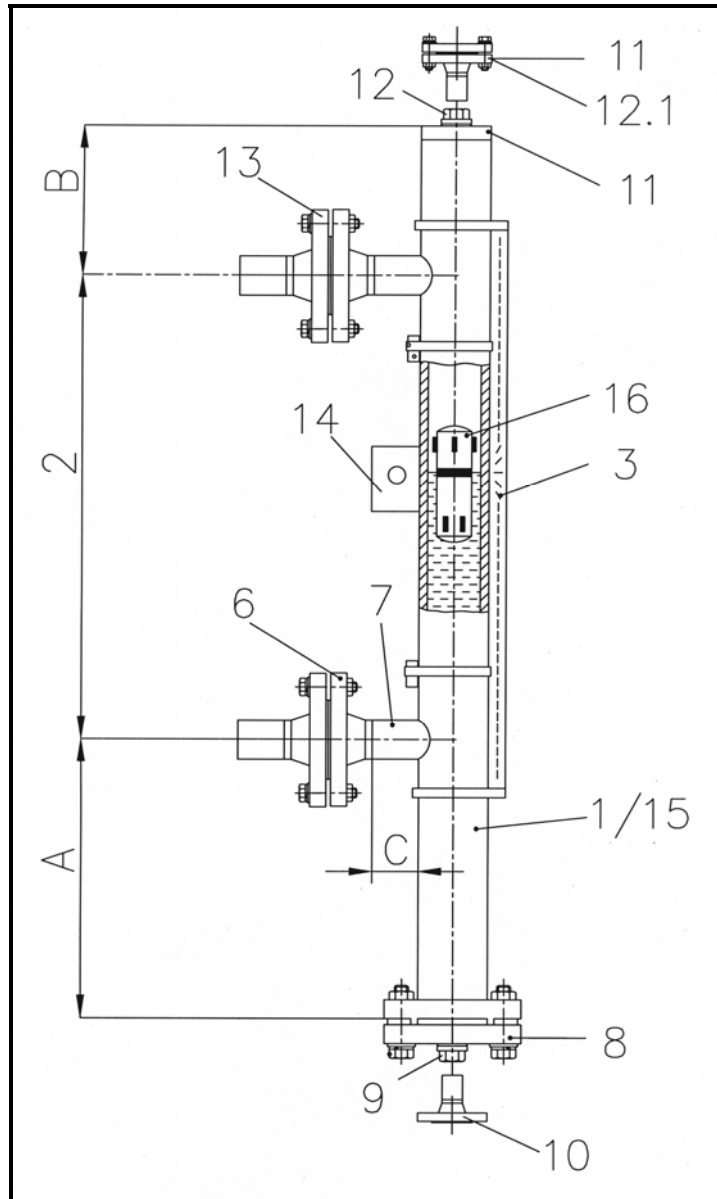

Parts drawing ITA-3.0 Cryo

**Key:**

- |   |   |    |                               |
|---|---|----|-------------------------------|
| 1 | Float pipe welded Dimensions 60,3 x 2 mm                | 9  | Drain plug                    |
| 2 | c to c distance   | 10 | Additional drain flange, open |
| 3 | Design (indication rail)                                | 11 | Float pipe top end finish     |
| 4 | Armaflex insulation                                     | 12 | Vent plug                     |
| 6 | Process connection side/side                            | 13 | Counter flanges               |
| 7 | Side studs welded with T-pieces for 100 % X-ray testing | 14 | Additional bracket            |
| 8 | Float removal flange                                    | 15 | Float pipe seamless           |
|   |   | 16 | Float                         |

<b>Technical specification magnetic level gauge type ITA 3.0 Cryo</b>
---

Principle	:	Communicating tubes with magnetic float
Mounting position	:	vertical
Measuring range	:	<b>max. 5000 mm (one-part)</b> > 5000 mm 2- or multipart
Pipe diameter	:	<b>60,3 x 2 mm welded,</b>
Process connection	:	to specify: <b>Flanges DN15-50 (1/2"-2"150#),</b> <b>Welding or threaded stud</b>
Drain/vent connections	:	<b>Plug G1/2"</b>
Pipe material	:	<b>1.4404</b> , 1.4435, 1.4539, Hastelloy C4 (2.4610), Inconel 625 (2.4856), Inconel 825 (2.4858), Titan (3.7035) Other materials also possible (on request)
Flange material	:	Carbon steel
Float material	:	<b>1.4404</b> Titanium, Titanium/E-CTFE-coated
Operation temperature	:	-200...+100 °C
Operation pressure	:	max. 16 bar
Operation density	:	min. 0,4017 kg/dm <sup>3</sup>
Bolts & Nuts	:	<b>CS</b> (min. -10 °C) SS or material in acc. with DIN 17280
Gasket	:	<b>PTFE min. -150 °C</b> <b>Klingersil TOP Chem 2000</b>
Indication rail	:	<b>Aluminium</b> 1.4301
Float types	:	Cylindrical, sealed type Length: - <b>270 mm*</b>

**Base equipment printed in bold letters!**

**\* not for vaporizing media (e.g. ammonia)**

<b>Order codes for magnetic level gauge type ITA-3 Cryo and ITA-3.0 Cryo</b>
--

Code	Description
ITA-3-Cryo ITA-3.0-Cryo	<b>1. Float pipe welded</b> <b>Dimensions 60,3 x 2 mm</b>
	<b>2. C to C distance</b>
L	C to C distance in mm
	<b>3. Design</b>
0	without indication rail
1	Indication rail material: Aluminium max. 400 °C
2	Indication rail material: 1.4401 max. 400 °C
	<b>4. Armaflex-Insulation</b>
0	without insulation
F	Thickness: 12 mm, up to -15 °C
R	Thickness: 30 mm, up to -50 °C
T	Thickness: 70 mm, up to -200 °C, incl. Makrolon window
	<b>5. C to C distance &lt; 5000 mm</b>
A	< 5000 mm - without flange connection; DN 32 PN 16
B	> 5000 mm - with flange connection; DN 32 PN 16
	<b>6. Process connection side/side</b>
Y	Welding connection (please specify)
Z	Threaded connection (please specify)
1	Flanges DN 15 PN 16
2	Flanges DN 20 PN 16
3	Flanges DN 25 PN 16
4	Flanges DN 32 PN 16
5	Flanges DN 40 PN 16
6	Flanges DN 50 PN 16
A	Flanges 1/2" ANSI 150 lbs
B	Flanges 3/4" ANSI 150 lbs
C	Flanges 1" ANSI 150 lbs
D	Flanges 1 1/4" ANSI 150 lbs
E	Flanges 1 1/2" ANSI 150 lbs
F	Flanges 2" ANSI 150 lbs
	<b>6.1 Surface side flanges</b>
0	without
F	Surface groove (DIN2512)
H	Surface tongue (DIN2512)
	<b>7. Side studs welded with T-pieces for 100 % X-ray testing</b>
0	without
T	T-pieces

**Order codes for magnetic level gauge type ITA-3 Cryo and ITA-3.0 Cryo (Cont.)**

Code	Description
<b>8. Float removal flange (bottom side)</b>	
1	End cap (only if float removal flange (top side))
2	Flange DN 32 PN 16 incl. blind flange
3	Flange DN 50 PN 16 incl. blind flange
A	Flange 2" ANSI 150 lbs incl. blind flange
B	Flange DN 50 PN 16 reinforced for shut off valve on side
C	Flange 2" ANSI 150 lbs reinforced for shut off valve on side
<b>8.1 Surface float removal flange (bottom side) (only DN50 or 2")</b>	
0	without (Float removal flange (bottom side) = end cap or < DN50 or 2")
A	Standard- Surface Form C
B	Standard-Surface RF
C	Surface Form D Rz=40
D	Surface Form E Rz=16
E	Surface RFSF (smooth finished)
F	Surface groove (DIN2512)
G	Surface groove large
H	Surface tongue (DIN2512)
K	Surface tongue-large
L	Surface RTJ (ANSI) 1/2" bis 2"
<b>8.2 Bolts &amp; nuts float removal flange (bottom side)</b>	
0	without (Float removal flange (bottom side) = end cap)
1	M16 x 65 mm; mat. zinc steel; flange DN 32 PN 16
2	M16 x 65 mm; mat. stainless steel 1.4301; flange DN 32 PN 16
3	M16 x 65 mm; mat. zinc steel; flange DN 50 PN 16
4	M16 x 65 mm; mat. stainless steel 1.4301; flange DN 50 PN 16
A	5/8" x 83; mat. zinc steel A193B7; fange 2" ANSI 150 lbs
B	5/8" x 83; mat. stainless steel A193B8 A1948M; flange 2" ANSI 150 lbs
C	Bolts & nuts PTFE coated (only DN 50 or 2")
<b>9. Drain plug</b>	
0	without
1	Drain plug G 1/2" with soft iron gasket
2	Drain plug 1/2" NPT
3	Drain plug 3/4" NPT
4	Drain plug 1" NPT
<b>10. Additional drain flange, open</b>	
0	without
1	Drain stud with flange DN 15 PN 16
2	Drain stud with flange DN 20 PN 16
3	Drain stud with flange DN 25 PN 16
4	Drain stud with flange DN 32 PN 16
5	Drain stud with flange DN 40 PN 16
6	Drain stud with flange DN 50 PN 16
A	Drain stud with flange 1/2" ANSI 150 lbs
B	Drain stud with flange 3/4" ANSI 150 lbs
C	Drain stud with flange 1" ANSI 150 lbs
D	Drain stud with flange 1 1/4" ANSI 150 lbs
E	Drain stud with flange 1 1/2" ANSI 150 lbs
F	Drain stud with flange 2" ANSI 150 lbs



**Order codes for magnetic level gauge type ITA-3 Cryo and ITA-3.0 Cryo (Cont.)**

Code	Description
<b>10.1 Surface open drain flange</b>	
0	without (Float removal flange (bottom side) = end cap or < DN50 or 2")
A	Standard- Surface Form C
B	Standard-Surface RF
C	Surface Form D Rz=40
D	Surface Form E Rz=16
E	Surface RFSF (smooth finished)
F	Surface groove (DIN2512)
G	Surface groove large
H	Surface tongue (DIN2512)
K	Surface tongue-large
L	Surface RTJ (ANSI) 1/2" bis 2"
<b>11. Float pipe top end finish</b>	
1	End cap
2	Flange with blind flange DN 32 PN 16
3	Flange with blind flange DN 50 PN 16
A	Flange with blind flange 2" ANSI 150 lbs
<b>11.1 Surface float pipe top end finish flange (only DN50 or 2")</b>	
0	without (Float removal flange (bottom side) = end cap or < DN50 or 2")
A	Standard- Surface Form C
B	Standard-Surface RF
C	Surface Form D Rz=40
D	Surface Form E Rz=16
E	Surface RFSF (smooth finished)
F	Surface groove (DIN2512)
G	Surface groove large
H	Surface tongue (DIN2512)
K	Surface tongue-large
L	Surface RTJ (ANSI) 1/2" bis 2"
<b>11.2 Bolts &amp; nuts float pipe top end finish flange (only DN50 or 2")</b>	
0	without (Float removal flange (bottom side) = end cap)
1	M16 x 65 mm; mat. zinc steel; flange DN 32 PN 16
2	M16 x 65 mm; mat. stainless steel 1.4301; flange DN 32 PN 16
3	M16 x 65 mm; mat. zinc steel; flange DN 50 PN 16
4	M16 x 65 mm; mat. stainless steel 1.4301; flange DN 50 PN 16
A	5/8" x 83; mat. zinc steel A193B7; fange 2" ANSI 150 lbs
B	5/8" x 83; mat. stainless steel A193B8 A1948M; flange 2" ANSI 150 lbs
C	Bolts & nuts PTFE coated (only DN 50 or 2")
<b>12. Vent plug at top end</b>	
0	without
1	Vent plug G 1/2" with soft iron gasket
2	Vent plug 1/2" NPT
3	Vent plug 3/4" NPT
4	Vent plug 1" NPT

**Order codes for magnetic level gauge type ITA-3 Cryo and ITA-3.0 Cryo (Cont.)**

Code	Description
<b>12.1 Vent flange welded to end cap instead of vent plug</b>	
0	without
1	Flanged DN 15 PN 16 (socket weld construction to endcap)
2	Flanged DN 20 PN 16 (socket weld construction to endcap)
3	Flanged DN 25 PN 16 (socket weld construction to endcap)
4	Flanged DN 32 PN 16 (socket weld construction to endcap)
5	Flanged DN 40 PN 16 (socket weld construction to endcap)
6	Flanged DN 50 PN 16 (socket weld construction to endcap)
A	Flanged 1/2" ANSI 150 lbs (socket weld construction to endcap)
B	Flanged 3/4" ANSI 150 lbs (socket weld construction to endcap)
C	Flanged 1" ANSI 150 lbs (socket weld construction to endcap)
D	Flanged 1 1/4" ANSI 150 lbs (socket weld construction to endcap)
E	Flanged 1 1/2" ANSI 150 lbs (socket weld construction to endcap)
F	Flanged 2" ANSI 150 lbs (socket weld construction to endcap)
<b>12.2 Surface vent flange welded to end cap (only DN50 or 2")</b>	
0	without (Vent flange welded to end cap = without)
B	Surface RF
C	Surface Form D Rz=40
D	Surface Form E Rz=16
E	Surface RFSF (ANSI)
F	Surface groove (DIN2512)
G	Surface groove large ANSI
H	Surface tongue (DIN2512)
K	Surface tongue-large ANSI
L	Surface RTJ (ANSI) 1/2" bis 2"
<b>13. Counter flanges</b>	
0	without
1	DN 15 PN 16
2	DN 20 PN 16
3	DN 25 PN 16
4	DN 32 PN 16
5	DN 40 PN 16
6	DN 50 PN 16
A	1/2" 150 lbs
B	3/4" 150 lbs
C	1" 150 lbs
D	1 1/4" 150 lbs
E	1 1/2" 150 lbs
F	2" 150 lbs

**Order codes for magnetic level gauge type ITA-3 Cryo and ITA-3.0 Cryo (Cont.)**

Code	Description
<b>13.1 Surface counter flanges</b>	
0	without (Counter flanges = without)
F	Surface groove (DIN2512)
H	Surface tongue (DIN2512)
<b>13.2 Bolts &amp; Nuts counter flanges</b>	
0	without (Counter flanges = without)
1	M16 x 65 mm; mat. zincd steel; flange DN 32 PN 16
2	M16 x 65 mm; mat. stainless steel 1.4301; flange DN 32 PN 16
3	M16 x 65 mm; mat. zincd steel; flange DN 50 PN 16
4	M16 x 65 mm; mat. stainless steel 1.4301; flange DN 50 PN 16
A	5/8" x 83; mat. zincd steel A193B7; flange 2" ANSI 150 lbs
B	5/8" x 83; mat. stainless steel A193B8 A1948M; flange 2" ANSI 150 lbs
C	Bolts & nuts PTFE coated (only DN 50 or 2")
<b>14. Additional bracket welded to the float pipe</b>	
0	without
H	Bracket
<b>15. Float pipe seamless</b>	
0	without
S	60,3 x 2 mm seamless
<b>16. Float</b>	
F7C2SY	50,8 x 270; material: Titanium*; pressure max. 16 bar; min. density of fluid: 0,5723 kg/dm <sup>3</sup> sealed
K7C2SY	44,5 x 530; material: Titanium*; pressure max. 16 bar; min. density of fluid: 0,6502kg/dm <sup>3</sup> sealed

1	2	3	4	5	6	7	8	9	10	11	12	13	14	15	16					
ITA-3-Cryo	L= mm															7	C	2	S	Y

1	2	3	4	5	6	7	8	9	10	11	12	13	14	15	16					
ITA-3.0-Cryo	L= mm															7	C	2	S	Y

**3.3.1 ITA-3 CR64 (cryogenic applications)**

Characteristics: PN16 / Float pipe and flange material 1.4404

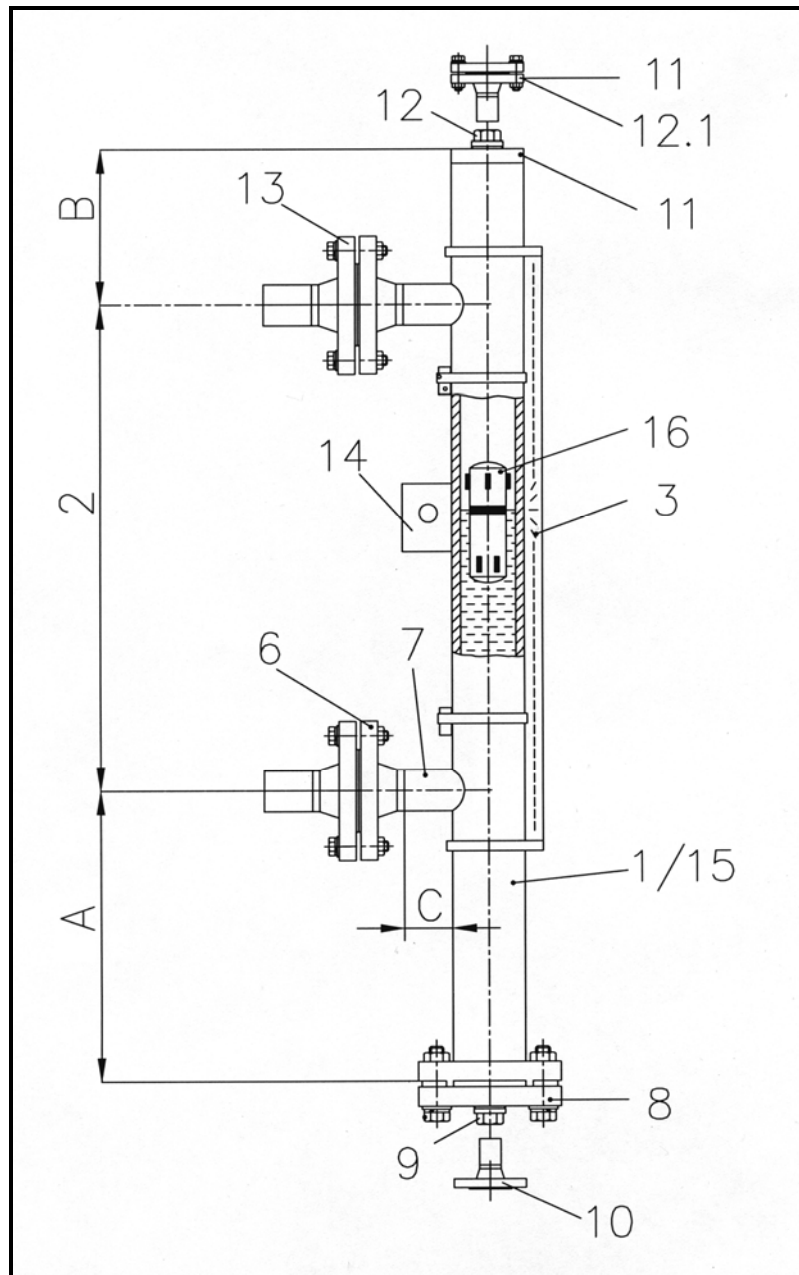

Parts drawing ITA-3 CR64

**Key:**

- |   |   |    |                               |
|---|---|----|-------------------------------|
| 1 | Float pipe welded Dimensions 64 x 2 mm                  | 9  | Drain plug                    |
| 2 | c to c distance   | 10 | Additional drain flange, open |
| 3 | Design (indication rail)                                | 11 | Float pipe top end finish     |
| 4 | Armaflex insulation                                     | 12 | Vent plug                     |
| 6 | Process connection side/side                            | 13 | Counter flanges               |
| 7 | Side studs welded with T-pieces for 100 % X-ray testing | 14 | Additional bracket            |
| 8 | Float removal flange                                    | 15 | Float pipe seamless           |
|   |   | 16 | Float                         |

### Technical specification magnetic level gauge type ITA 3 CR64

Principle	:	Communicating tubes with magnetic float
Mounting position	:	vertical
Measuring range	:	<b>max. 5000 mm (one-part)</b> > 5000 mm 2- or multipart
Pipe diameter	:	<b>64 x 2 mm welded,</b>
Process connection	:	to specify: <b>Flanges DN15-50 (1/2"-2"150#),</b> <b>Welding or threaded stud</b>
Drain/vent connections	:	<b>Plug G1/2"</b>
Pipe material	:	<b>1.4404</b> , 1.4435, 1.4539, Hastelloy C4 (2.4610), Inconel 625 (2.4856), Inconel 825 (2.4858), Titan (3.7035) Other materials also possible (on request)
Flange material	:	same as pipe material
Float material	:	<b>1.4404</b> Titanium, Titanium/E-CTFE-coated
Operation temperature	:	-200...+100 °C
Operation pressure	:	max. 16 bar
Operation density	:	min. 0,4017 kg/dm <sup>3</sup>
Bolts & Nuts	:	<b>CS</b> (min. -10 °C) SS or material in acc. with DIN 17280
Gasket	:	<b>PTFE min. -150 °C</b> <b>Klingersil TOP Chem 2000</b>
Indication rail	:	<b>Aluminium</b> 1.4301
Float types	:	Cylindrical, sealed type Length: - <b>Ø50,8 x 270 mm*</b> - Ø50,8 x 530 mm

**Base equipment printed in bold letters!**

**\* not for vaporizing media (e.g. ammonia)**

**3.3.2 ITA-3.0 CR64 (cryogenic applications)**

Characteristics: PN16 / Float pipe: 1.4404 Flanges: CS

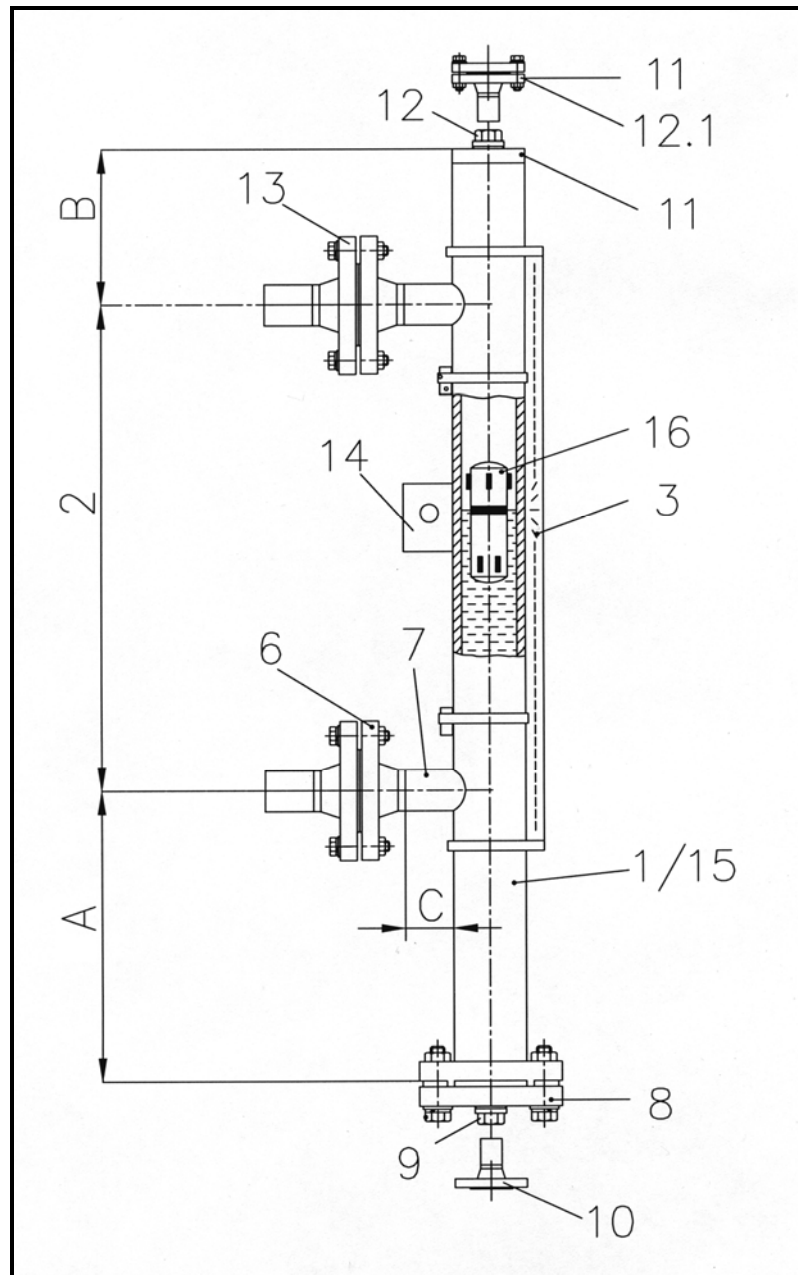

Parts drawing ITA-3 CR64

**Key:**

- |   |   |    |                               |
|---|---|----|-------------------------------|
| 1 | Float pipe welded Dimensions 64 x 2 mm                  | 9  | Drain plug                    |
| 2 | c to c distance   | 10 | Additional drain flange, open |
| 3 | Design (indication rail)                                | 11 | Float pipe top end finish     |
| 4 | Armaflex insulation                                     | 12 | Vent plug                     |
| 6 | Process connection side/side                            | 13 | Counter flanges               |
| 7 | Side studs welded with T-pieces for 100 % X-ray testing | 14 | Additional bracket            |
| 8 | Float removal flange                                    | 15 | Float pipe seamless           |
|   |   | 16 | Float                         |

<b>Technical specification magnetic level gauge type ITA 3.0 CR64</b>
---

Principle	:	Communicating tubes with magnetic float
Mounting position	:	vertical
Measuring range	:	<b>max. 5000 mm (one-part)</b> > 5000 mm 2- or multipart
Pipe diameter	:	<b>64 x 2 mm welded,</b>
Process connection	:	to specify: <b>Flanges DN15-50 (1/2"-2"150#),</b> <b>Welding or threaded stud</b>
Drain/vent connections	:	<b>Plug G1/2"</b>
Pipe material	:	<b>1.4404</b> , 1.4435, 1.4539, Hastelloy C4 (2.4610), Inconel 625 (2.4856), Inconel 825 (2.4858), Titan (3.7035) Other materials also possible (on request)
Flange material	:	Carbon steel
Float material	:	<b>1.4404</b> Titanium, Titanium/E-CTFE-coated
Operation temperature	:	-200...+100 °C
Operation pressure	:	max. 16 bar
Operation density	:	min. 0,4017 kg/dm <sup>3</sup>
Bolts & Nuts	:	<b>CS</b> (min. -10 °C) SS or material in acc. with DIN 17280
Gasket	:	<b>PTFE min. -150 °C</b> <b>Klingersil TOP Chem 2000</b>
Indication rail	:	<b>Aluminium</b> 1.4301
Float types	:	Cylindrical, sealed type Length: - <b>Ø50,8 x 270 mm*</b> - Ø50,8 x 530 mm

**Base equipment printed in bold letters!**

**\* not for vaporizing media (e.g. ammonia)**

**Order codes for magnetic level gauge type ITA-3 CR64 and ITA-3.0 CR64**

Code	Description
ITA-3-CR64 ITA-3.0-CR64	<b>1. Float pipe welded</b> <b>Dimensions 64 x 2 mm</b>
	<b>2. C to C distance</b>
L	C to C distance in mm
	<b>3. Design</b>
0	without indication rail
1	Indication rail material: Aluminium max. 400 °C
2	Indication rail material: 1.4401 max. 400 °C
	<b>4. Armaflex-Insulation</b>
0	without insulation
F	Thickness: 12 mm, up to -15 °C
R	Thickness: 30 mm, up to -50 °C
T	Thickness: 70 mm, up to -200 °C, incl. Makrolon window
	<b>5. C to C distance &lt; 5000 mm</b>
A	< 5000 mm - without flange connection; DN 32 PN 16
B	> 5000 mm - with flange connection; DN 32 PN 16
	<b>6. Process connection side/side</b>
Y	Welding connection (please specify)
Z	Threaded connection (please specify)
1	Flanges DN 15 PN 16
2	Flanges DN 20 PN 16
3	Flanges DN 25 PN 16
4	Flanges DN 32 PN 16
5	Flanges DN 40 PN 16
6	Flanges DN 50 PN 16
A	Flanges 1/2" ANSI 150 lbs
B	Flanges 3/4" ANSI 150 lbs
C	Flanges 1" ANSI 150 lbs
D	Flanges 1 1/4" ANSI 150 lbs
E	Flanges 1 1/2" ANSI 150 lbs
F	Flanges 2" ANSI 150 lbs
	<b>6.1 Surface side flanges</b>
0	without
F	Surface groove (DIN2512)
H	Surface tongue (DIN2512)
	<b>7. Side studs welded with T-pieces for 100 % X-ray testing</b>
0	without
T	T-pieces
	<b>8. Float removal flange (bottom side)</b>
1	End cap (only if float removal flange (top side))
2	Flange DN 32 PN 16 incl. blind flange
3	Flange DN 50 PN 16 incl. blind flange
A	Flange 2" ANSI 150 lbs incl. blind flange
4	Flange DN 50 PN 16 reinforced for shut off valve on side
B	Flange 2" ANSI 150 lbs reinforced for shut off valve on side



**Order codes for magnetic level gauge type ITA-3 CR64 and ITA-3.0 CR64 (Cont.)**

Code	Description
<b>8.1 Surface float removal flange (bottom side) (only DN50 or 2")</b>	
0	without (Float removal flange (bottom side) = end cap or < DN50 or 2")
A	Standard- Surface Form C
B	Standard-Surface RF
C	Surface Form D Rz=40
D	Surface Form E Rz=16
E	Surface RFSF (smooth finished)
F	Surface groove (DIN2512)
G	Surface groove large
H	Surface tongue (DIN2512)
K	Surface tongue-large
L	Surface RTJ (ANSI) 1/2" bis 2"
<b>8.2 Bolts &amp; nuts float removal flange (bottom side)</b>	
0	without (Float removal flange (bottom side) = end cap)
1	M16 x 65 mm; mat. zincd steel; flange DN 32 PN 16
2	M16 x 65 mm; mat. stainless steel 1.4301; flange DN 32 PN 16
3	M16 x 65 mm; mat. zincd steel; flange DN 50 PN 16
4	M16 x 65 mm; mat. stainless steel 1.4301; flange DN 50 PN 16
A	5/8" x 83; mat. zincd steel A193B7; fange 2" ANSI 150 lbs
B	5/8" x 83; mat. stainless steel A193B8 A1948M; flange 2" ANSI 150 lbs
C	Bolts & nuts PTFE coated (only DN 50 or 2")
<b>9. Drain plug</b>	
0	without
1	Drain plug G 1/2" with soft iron gasket
2	Drain plug 1/2" NPT
3	Drain plug 3/4" NPT
4	Drain plug 1" NPT
<b>10. Additional drain flange, open</b>	
0	without
1	Drain stud with flange DN 15 PN 16
2	Drain stud with flange DN 20 PN 16
3	Drain stud with flange DN 25 PN 16
4	Drain stud with flange DN 32 PN 16
5	Drain stud with flange DN 40 PN 16
6	Drain stud with flange DN 50 PN 16
A	Drain stud with flange 1/2" ANSI 150 lbs
B	Drain stud with flange 3/4" ANSI 150 lbs
C	Drain stud with flange 1" ANSI 150 lbs
D	Drain stud with flange 1 1/4" ANSI 150 lbs
E	Drain stud with flange 1 1/2" ANSI 150 lbs
F	Drain stud with flange 2" ANSI 150 lbs

**Order codes for magnetic level gauge type ITA-3 CR64 and ITA-3.0 CR64 (Cont.)**

Code	Description
<b>10.1 Surface open drain flange</b>	
0	without (Float removal flange (bottom side) = end cap or < DN50 or 2")
A	Standard- Surface Form C
B	Standard-Surface RF
C	Surface Form D Rz=40
D	Surface Form E Rz=16
E	Surface RFSF (smooth finished)
F	Surface groove (DIN2512)
G	Surface groove large
H	Surface tongue (DIN2512)
K	Surface tongue-large
L	Surface RTJ (ANSI) 1/2" bis 2"
<b>11. Float pipe top end finish</b>	
1	End cap
2	Flange with blind flange DN 32 PN 16
3	Flange with blind flange DN 50 PN 16
A	Flange with blind flange 2" ANSI 150 lbs
<b>11.1 Surface float pipe top end finish flange (only DN50 or 2")</b>	
0	without (Float removal flange (bottom side) = end cap or < DN50 or 2")
A	Standard- Surface Form C
B	Standard-Surface RF
C	Surface Form D Rz=40
D	Surface Form E Rz=16
E	Surface RFSF (smooth finished)
F	Surface groove (DIN2512)
G	Surface groove large
H	Surface tongue (DIN2512)
K	Surface tongue-large
L	Surface RTJ (ANSI) 1/2" bis 2"
<b>11.2 Bolts &amp; nuts float pipe top end finish flange (only DN50 or 2")</b>	
0	without (Float removal flange (bottom side) = end cap)
1	M16 x 65 mm; mat. zincd steel; flange DN 32 PN 16
2	M16 x 65 mm; mat. stainless steel 1.4301; flange DN 32 PN 16
3	M16 x 65 mm; mat. zincd steel; flange DN 50 PN 16
4	M16 x 65 mm; mat. stainless steel 1.4301; flange DN 50 PN 16
A	5/8" x 83; mat. zincd steel A193B7; fange 2" ANSI 150 lbs
B	5/8" x 83; mat. stainless steel A193B8 A1948M; flange 2" ANSI 150 lbs
C	Bolts & nuts PTFE coated (only DN 50 or 2")
<b>12. Vent plug at top end</b>	
0	without
1	Vent plug G 1/2" with soft iron gasket
2	Vent plug 1/2" NPT
3	Vent plug 3/4" NPT
4	Vent plug 1" NPT

**Order codes for magnetic level gauge type ITA-3 CR64 and ITA-3.0 CR64 (Cont.)**

Code	Description
<b>12.1 Vent flange welded to end cap instead of vent plug</b>	
0	without
1	Flanged DN 15 PN 16 (socket weld construction to endcap)
2	Flanged DN 20 PN 16 (socket weld construction to endcap)
3	Flanged DN 25 PN 16 (socket weld construction to endcap)
4	Flanged DN 32 PN 16 (socket weld construction to endcap)
5	Flanged DN 40 PN 16 (socket weld construction to endcap)
6	Flanged DN 50 PN 16 (socket weld construction to endcap)
A	Flanged 1/2" ANSI 150 lbs (socket weld construction to endcap)
B	Flanged 3/4" ANSI 150 lbs (socket weld construction to endcap)
C	Flanged 1" ANSI 150 lbs (socket weld construction to endcap)
D	Flanged 1 1/4" ANSI 150 lbs (socket weld construction to endcap)
E	Flanged 1 1/2" ANSI 150 lbs (socket weld construction to endcap)
F	Flanged 2" ANSI 150 lbs (socket weld construction to endcap)
<b>12.2 Surface vent flange welded to end cap (only DN50 or 2")</b>	
0	without (Vent flange welded to end cap = without)
A	Surface RF
B	Surface Form D Rz=40
C	Surface Form E Rz=16
D	Surface RFSF (ANSI)
E	Surface groove (DIN2512)
F	Surface groove large ANSI
G	Surface tongue (DIN2512)
H	Surface tongue-large ANSI
K	Surface RTJ (ANSI) 1/2" bis 2"
L	Dichtfläche RTJ (ANSI)
<b>13. Counter flanges</b>	
0	without
1	DN 15 PN 16
2	DN 20 PN 16
3	DN 25 PN 16
4	DN 32 PN 16
5	DN 40 PN 16
6	DN 50 PN 16
A	1/2" 150 lbs
B	3/4" 150 lbs
C	1" 150 lbs
D	1 1/4" 150 lbs
E	1 1/2" 150 lbs
F	2" 150 lbs
<b>13.1 Surface counter flanges</b>	
0	without (Counter flanges = without)
F	Surface groove (DIN2512)
H	Surface tongue (DIN2512)

**Order codes for magnetic level gauge type ITA-3 CR64 and ITA-3.0 CR64 (Cont.)**

Code	Description
<b>13.2 Bolts &amp; Nuts counter flanges</b>	
0	without (Counter flanges = without)
1	M16 x 65 mm; mat. zincd steel; flange DN 32 PN 16
2	M16 x 65 mm; mat. stainless steel 1.4301; flange DN 32 PN 16
3	M16 x 65 mm; mat. zincd steel; flange DN 50 PN 16
4	M16 x 65 mm; mat. stainless steel 1.4301; flange DN 50 PN 16
A	5/8" x 83; mat. zincd steel A193B7; flange 2" ANSI 150 lbs
B	5/8" x 83; mat. stainless steel A193B8 A1948M; flange 2" ANSI 150 lbs
C	Bolts & nuts PTFE coated (only DN 50 or 2")
<b>14. Additional bracket welded to the float pipe</b>	
0	without
H	Bracket
<b>15. Float pipe seamless</b>	
0	without
S	60,3 x 2 mm seamless
<b>16. Float</b>	
<b>F7C2SY</b>	50,8 x 270; material: Titanium*; pressure max. 16 bar; min. density of fluid: 0,5723 kg/dm <sup>3</sup> sealed
<b>K7C2SY</b>	44,5 x 530; material: Titanium*; pessure max. 16 bar; min. density of fluid: 0,6502kg/dm <sup>3</sup> sealed

1	2	3	4	5	6	7	8	9	10	11	12	13	14	15	16					
ITA-3-CR64	L=	mm														7	C	2	S	Y

1	2	3	4	5	6	7	8	9	10	11	12	13	14	15	16					
ITA-3.0-CR64	L=	mm														7	C	2	S	Y

### 3.4 ITA-3.5 (wetted parts E-CTFE-coated)

Characteristics: PN16 / Float pipe and flange material 1.4404

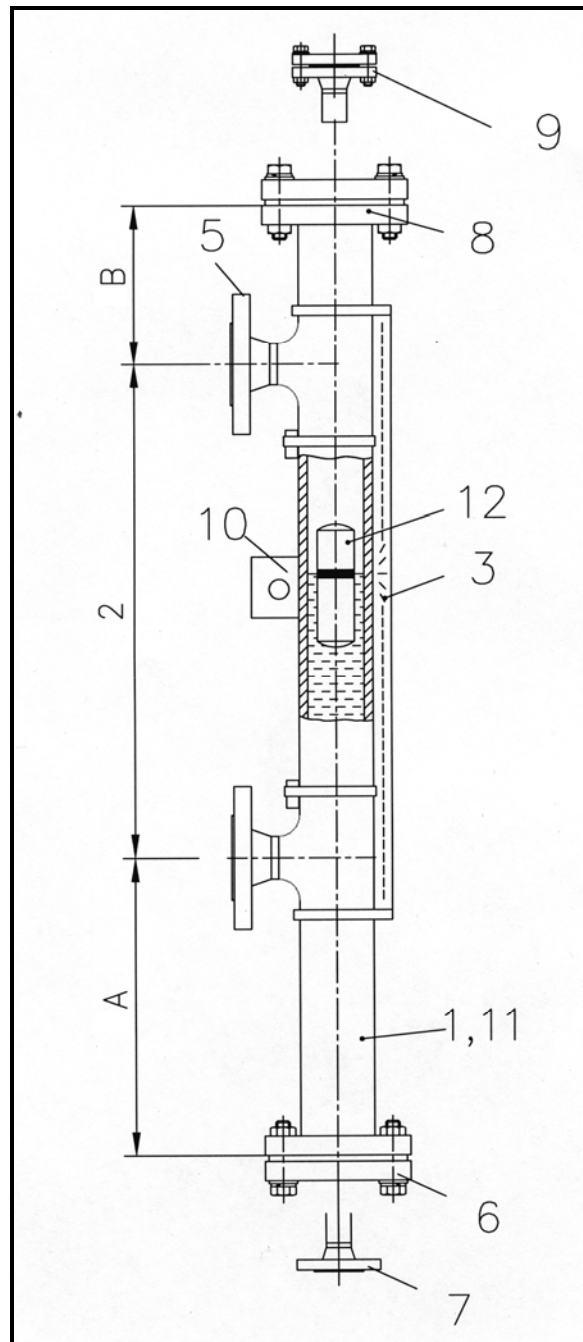

Parts drawing ITA-3.5

**Key:**

- |   |  |    |                               |
|---|--|----|-------------------------------|
| 1 | Float pipe welded Dimensions 60,3 x 2 mm | 7  | Additional drain flange, open |
| 2 | c to c distance                          | 8  | Float pipe top end finish     |
| 3 | Design (indication rail)                 | 9  | Additional bracket            |
| 5 | Process connection side/side             | 10 | Float pipe seamless           |
| 6 | Float removal flange                     | 11 | Vent plug                     |
| 7 | Additional drain flange, open            |    |                               |
| 8 | Float pipe top end finish                |    |                               |

<b>Technical specification magnetic level gauge type ITA 3.5</b>
--

Principle	:	Communicating tubes with magnetic float
Mounting position	:	vertical
Measuring range	:	<b>max. 3100 mm (one-part/total length max. 3500 mm)</b> > 3100 mm 2- or multipart
Pipe diameter	:	<b>60,3 x 2 mm welded,</b>
Process connection	:	to specify: <b>Flanges DN20-50 (1/2"-2"150#),</b> <b>Welding or threaded stud</b>
Drain/vent connections	:	<b>see price list</b>
Pipe material	:	<b>1.4404, wetted parts E-CTFE-coated (Halar)</b>
Flange material	:	as pipe material
Float material	:	<b>Titanium/E-CTFE-coated (Halar)</b>
Operation temperature	:	-50...+160 °C
Operation pressure	:	max. 16 bar
Operation density	:	min. 0,5645 kg/dm <sup>3</sup>
Bolts & Nuts	:	<b>CS</b> SS
Gasket	:	<b>PTFE min. -150 °C</b> <b>Klingersil TOP Chem 2000</b>
Indication rail	:	<b>Aluminium</b> 1.4301
Float types	:	Cylindrical, sealed type Length: - <b>270 mm</b> - 130 mm
Dimensions	:	- A= 240* - B= 130

**Base equipment printed in bold letters!**

**\* for densities < 1,0 kg/dm<sup>3</sup> enlarge the scale A**

**Order codes for magnetic level gauge type ITA-3.5**

Code	Description
<b>ITA-3.5</b>	<b>1. Float pipe welded Dimensions 60,3 x 2 mm</b>
	<b>2. c to c distance</b>
L	c to c distance in mm
	<b>3. Design</b>
0	without indication rail
1	Indication rail material Aluminium max. 400 °C
2	Indication rail material 1.4401 max. 400 °C
	<b>4. c to c distance &lt; 3100 mm, total length 3500 mm</b>
A	< 3100 mm - without flange connection; DN 32 PN 16
B	> 3100 mm - with flange connection; DN 32 PN 16
	<b>5. Process connection side/side</b>
1	Flanges DN 20 PN 16
2	Flanges DN 25 PN 16
3	Flanges DN 32 PN 16
4	Flanges DN 40 PN 16
5	Flanges DN 50 PN 16
A	Flanges 3/4" ANSI 150 lbs
B	Flanges 1" ANSI 150 lbs
C	Flanges 1 1/4" ANSI 150 lbs
D	Flanges 1 1/2" ANSI 150 lbs
E	Flanges 2" ANSI 150 lbs
	<b>5.1 Surface side flanges</b>
0	without
A	Standard- Surface Form C
B	Standard-Surface RF
	<b>6. Float removal flange (bottom side)</b>
1	Flange DN 50 PN 16 incl. blind flange
A	Flange 2" ANSI 150 lbs incl. blind flange
	<b>6.1 Bolts &amp; nuts float removal flange (bottom side)</b>
1	M16 x 65 mm; mat. zincd steel; flange DN 32 PN 16
2	M16 x 65 mm; mat. stainless steel 1.4301; flange DN 32 PN 16
3	M16 x 65 mm; mat. zincd steel; flange DN 50 PN 16
4	M16 x 65 mm; mat. stainless steel 1.4301; flange DN 50 PN 16
A	5/8" x 83; mat. zincd steel A193B7; fange 2" ANSI 150 lbs
B	5/8" x 83; mat. stainless steel A193B8 A1948M; flange 2" ANSI 150 lbs
C	Bolts & nuts PTFE coated (only DN 50 or 2")
	<b>7. Additional drain flange, open</b>
0	without
1	Drain stud with flange DN 20 PN 16
2	Drain stud with flange DN 25 PN 16
3	Drain stud with flange DN 32 PN 16
4	Drain stud with flange DN 40 PN 16
A	Drain stud with flange 3/4" ANSI 150 lbs
B	Drain stud with flange 1" ANSI 150 lbs
C	Drain stud with flange 1 1/4" ANSI 150 lbs
D	Drain stud with flange 1 1/2" ANSI 150 lbs

**Order codes for magnetic level gauge type ITA-3.5 (Continuation)**

Code	Description
<b>7.1 Drain flange with concentric reducer (X-ray testing)</b>	
0	without
1	DN 20 PN 16
2	DN 25 PN 16
3	DN 32 PN 16
4	DN 40 PN 16
A	3/4" ANSI 150 lbs
B	1" ANSI 150 lbs
C	1 1/4" ANSI 150 lbs
D	1 1/2" ANSI 150 lbs
<b>7.2 Surface open drain flange</b>	
A	Surface Form C
B	Surface RF
<b>8. Float pipe top end finish</b>	
1	Flange with blind flange DN 32 PN 16
2	Flange with blind flange DN 50 PN 16
A	Flange with blind flange 2" ANSI 150 lbs
<b>8.1 Float pipe top end finish with concentric reducer (X-ray testing)</b>	
0	without
1	DN 20 PN 16
2	DN 25 PN 16
3	DN 32 PN 16
4	DN 40 PN 16
A	3/4" ANSI 150 lbs
B	1" ANSI 150 lbs
C	1 1/4" ANSI 150 lbs
D	1 1/2" ANSI 150 lbs
<b>8.2 Surface float pipe top end finish flange (only DN50 or 2")</b>	
A	Dichtleiste Form C
B	Dichtleiste RF
<b>8.3 Bolts &amp; nuts float pipe top end finish flange (only DN50 or 2")</b>	
1	M16 x 65 mm; mat. zincd steel; flange DN 32 PN 16
2	M16 x 65 mm; mat. stainless steel 1.4301; flange DN 32 PN 16
3	M16 x 65 mm; mat. zincd steel; flange DN 50 PN 16
4	M16 x 65 mm; mat. stainless steel 1.4301; flange DN 50 PN 16
A	5/8" x 83; mat. zincd steel A193B7; fange 2" ANSI 150 lbs
B	5/8" x 83; mat. stainless steel A193B8 A1948M; flange 2" ANSI 150 lbs
C	Bolts & nuts PTFE coated (only DN 50 or 2")



**Order codes for magnetic level gauge type ITA-3.5**

Code	Description
<b>9. Vent flange welded to end cap instead of vent plug</b>	
1	Flanged DN 20 PN 16 (socket weld construction to endcap)
2	Flanged DN 25 PN 16 (socket weld construction to endcap)
3	Flanged DN 32 PN 16 (socket weld construction to endcap)
4	Flanged DN 40 PN 16 (socket weld construction to endcap)
5	Flanged DN 50 PN 16 (socket weld construction to endcap)
A	Flanged 3/4" ANSI 150 lbs (socket weld construction to endcap)
B	Flanged 1" ANSI 150 lbs (socket weld construction to endcap)
C	Flanged 1 1/4" ANSI 150 lbs (socket weld construction to endcap)
D	Flanged 1 1/2" ANSI 150 lbs (socket weld construction to endcap)
E	Flanged 2" ANSI 150 lbs (socket weld construction to endcap)
<b>9.1 Vent flange with concentric reducer (X-ray testing)</b>	
0	without
1	DN 20 PN 16
2	DN 25 PN 16
3	DN 32 PN 16
4	DN 40 PN 16
A	3/4" ANSI 150 lbs
B	1" ANSI 150 lbs
C	1 1/4" ANSI 150 lbs
D	1 1/2" ANSI 150 lbs
<b>10. Additional bracket welded to the float pipe</b>	
0	without
H	Bracket
<b>11. Float pipe seamless</b>	
0	without
S	60,3 x 2 mm seamless
<b>12. Float</b>	
<b>F7C3SY</b>	50,8 x 270; material: Titanium, Halar-coated; pressure: max. 16 bar min. density of fluid: 0,6873 kg/dm <sup>3</sup> ; sealed
<b>B7C3SY</b>	50,8 x 150; material: Titanium, Halar-coated; pressure: max. 16 bar min. density of fluid: 0,902 kg/dm <sup>3</sup> ; sealed

1	2	3	4	5	6	7	8	9	10	11	12								
ITA-3.5	L=	mm													7	C	3	S	Y

**3.5 ITA-3.8 (wetted parts E-TFE-coated, for vacuum service)**

Characteristics: PN16 / Float pipe and flange material 1.4404

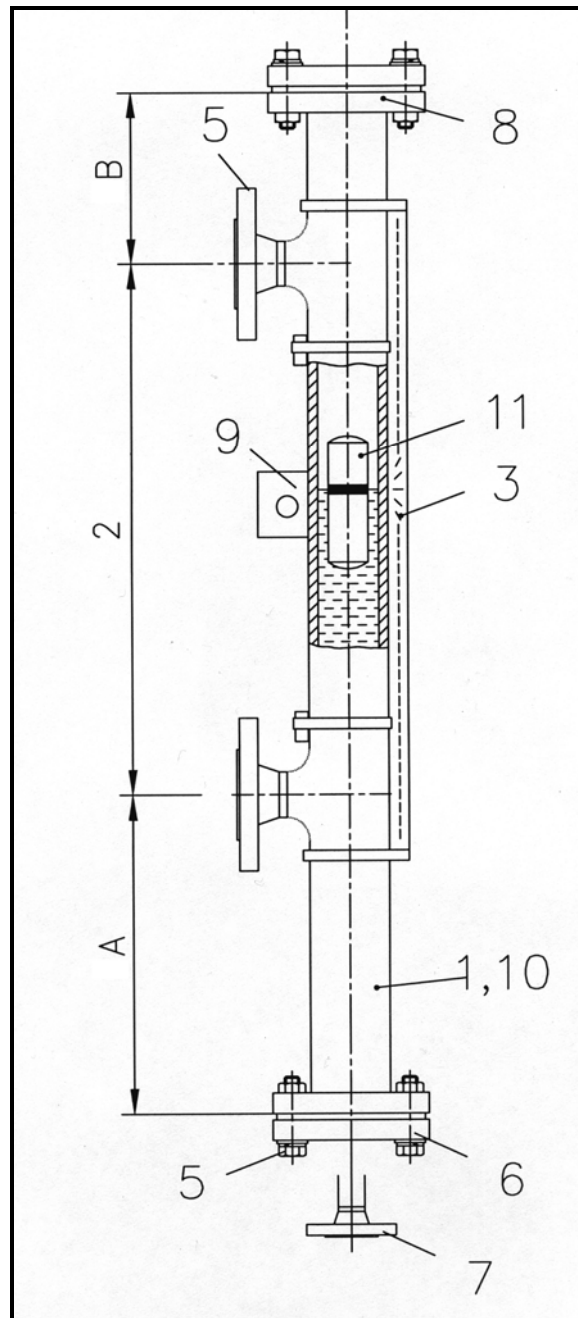

Parts drawing ITA-3.8

**Key:**

- |   |  |    |                               |
|---|--|----|-------------------------------|
| 1 | Float pipe welded Dimensions 60,3 x 2 mm | 7  | Additional drain flange, open |
| 2 | c to c distance                          | 8  | Float pipe top end finish     |
| 3 | Design (indication rail)                 | 9  | Additional bracket            |
| 5 | Process connection side/side             | 10 | Float pipe seamless           |
| 6 | Float removal flange                     | 11 | Vent plug                     |
| 7 | Additional drain flange, open            |    |                               |
| 8 | Float pipe top end finish                |    |                               |

### Technical specification magnetic level gauge type ITA-3.8

Principle	:	Communicating tubes with magnetic float
Mounting position	:	vertical
Measuring range	:	<b>max. 1700 mm (one-part/total length max. 2100 mm)</b> > 2100 mm 2- or multipart
Pipe diameter	:	<b>64 x 2 mm welded, necking connections</b>
Process connection	:	to specify: <b>Flanges DN15-25 (1/2"-1"150# RF)</b>
Drain/vent connections	:	<b>see price list</b>
Pipe material	:	<b>1.4404, wetted parts E-TFE-coated</b>
Thickness of coating	:	2,0 mm for DN15 (1/2") process flange 2,5 mm for DN20 (3/4") process flange 3,0 mm for DN25 (1") process flange
Flange material	:	as pipe material
Float material	:	<b>Titanium/E-TFE-coated</b>
Operation temperature	:	-50...+160 °C
Operation pressure	:	max. 16 bar / vacuum resistant
Operation density	:	min. 0,6873 kg/dm <sup>3</sup>
Bolts & Nuts	:	<b>CS</b> SS
Gasket	:	<b>PTFE up to 100 °C</b> <b>Klingersil-chem-200 up to 260 °C</b>
Indication rail	:	<b>Makrolon up to 120 °C</b> Aluminium up to 400 °C 1.4301 up to 400 °C
Float types	:	Cylindrical, sealed type Length: - <b>270 mm</b> - 150 mm
Dimensions	:	- A= 240* - B= 130 - C= 40

**Base equipment printed in bold letters!**

**Order codes for magnetic level gauge type ITA-3.8**

Code	Description
<b>ITA-3.8</b>	<b>1. Float pipe welded Dimensions 64 x 2 mm</b>
	<b>2. c to c distance</b>
<b>L</b>	c to c distance in mm
	<b>3. Design</b>
<b>0</b>	without indication rail
<b>1</b>	Indication rail material: Makrolon, max. 120 °C
<b>2</b>	Indication rail material: Aluminium max. 400 °C
<b>3</b>	Indication rail material: 1.4401 max. 400 °C
	<b>4. c to c distance &lt; 1700 mm, total length 2100 mm</b>
<b>A</b>	< 1700 mm - without flange connection; DN 32 PN 16
<b>B</b>	> 1700 mm - with flange connection; DN 32 PN 16
	<b>5. Process connection side/side</b>
<b>1</b>	Flanges DN 20 PN 16
<b>2</b>	Flanges DN 25 PN 16
<b>3</b>	Flanges DN 32 PN 16
<b>4</b>	Flanges DN 40 PN 16
<b>5</b>	Flanges DN 50 PN 16
<b>A</b>	Flanges 3/4" ANSI 150 lbs
<b>B</b>	Flanges 1" ANSI 150 lbs
<b>C</b>	Flanges 1 1/4" ANSI 150 lbs
<b>D</b>	Flanges 1 1/2" ANSI 150 lbs
<b>E</b>	Flanges 2" ANSI 150 lbs
	<b>5.1 Surface side flanges</b>
<b>A</b>	Standard- Surface Form C
<b>B</b>	Standard-Surface RF
	<b>6. Float removal flange (bottom side)</b>
<b>2</b>	Flange DN 50 PN 16 incl. blind flange
<b>A</b>	Flange 2" ANSI 150 lbs incl. blind flange
	<b>6.1 Surface Float removal flange (bottom side)</b>
<b>A</b>	Standard- Surface Form C
<b>B</b>	Standard-Surface RF
	<b>6.2 Bolts &amp; nuts float removal flange (bottom side)</b>
<b>1</b>	M16 x 65 mm; mat. zincd steel; flange DN 32 PN 16
<b>2</b>	M16 x 65 mm; mat. stainless steel 1.4301; flange DN 32 PN 16
<b>3</b>	M16 x 65 mm; mat. zincd steel; flange DN 50 PN 16
<b>4</b>	M16 x 65 mm; mat. stainless steel 1.4301; flange DN 50 PN 16
<b>A</b>	5/8" x 83; mat. zincd steel A193B7; fange 2" ANSI 150 lbs
<b>B</b>	5/8" x 83; mat. stainless steel A193B8 A1948M; flange 2" ANSI 150 lbs
<b>C</b>	Bolts & nuts PTFE coated (only DN 50 or 2")

**Order codes for magnetic level gauge type ITA-3.8 (Continuation)**

Code	Description
<b>7. Additional drain flange, open</b>	
0	without
1	Drain stud with flange DN 20 PN 16
2	Drain stud with flange DN 25 PN 16
3	Drain stud with flange DN 32 PN 16
4	Drain stud with flange DN 40 PN 16
A	Drain stud with flange 3/4" ANSI 150 lbs
B	Drain stud with flange 1" ANSI 150 lbs
C	Drain stud with flange 1 1/4" ANSI 150 lbs
D	Drain stud with flange 1 1/2" ANSI 150 lbs
<b>7.1 Surface open drain flange</b>	
0	without
A	Standard- Surface Form C
B	Standard-Surface RF
<b>7.2 Bolts &amp; Nuts open drain flange</b>	
0	without
1	M16 x 65 mm; mat. zincd steel; flange DN 32 PN 16
2	M16 x 65 mm; mat. stainless steel 1.4301; flange DN 32 PN 16
3	M16 x 65 mm; mat. zincd steel; flange DN 50 PN 16
4	M16 x 65 mm; mat. stainless steel 1.4301; flange DN 50 PN 16
A	5/8" x 83; mat. zincd steel A193B7; fange 2" ANSI 150 lbs
B	5/8" x 83; mat. stainless steel A193B8 A1948M; flange 2" ANSI 150 lbs
C	Bolts & nuts PTFE coated (only DN 50 or 2")
<b>8. Vent flange welded to blind flange</b>	
0	without
1	Flanged DN 15 PN 16 (socket weld construction to blind flange)
2	Flanged DN 20 PN 16 (socket weld construction to blind flange)
3	Flanged DN 25 PN 16 (socket weld construction to blind flange)
4	Flanged DN 32 PN 16 (socket weld construction to blind flange)
5	Flanged DN 40 PN 16 (socket weld construction to blind flange)
6	Flanged DN 50 PN 16 (socket weld construction to blind flange)
A	Flanged 1/2" ANSI 150 lbs (socket weld construction to blind flange)
B	Flanged 3/4" ANSI 150 lbs (socket weld construction to blind flange)
C	Flanged 1" ANSI 150 lbs (socket weld construction to blind flange)
D	Flanged 1 1/4" ANSI 150 lbs (socket weld construction to blind flange)
E	Flanged 1 1/2" ANSI 150 lbs (socket weld construction to blind flange)
F	Flanged 2" ANSI 150 lbs (socket weld construction to blind flange)
<b>8.1 Surface vent flange</b>	
0	without
A	Standard- Surface Form C
B	Standard-Surface RF

**Order codes for magnetic level gauge type ITA-3.8 (Continuation)**

Code	Description
<b>8.2 Bolts &amp; Nuts vent flange</b>	
0	without
1	M16 x 65 mm; mat. zincd steel; flange DN 32 PN 16
2	M16 x 65 mm; mat. stainless steel 1.4301; flange DN 32 PN 16
3	M16 x 65 mm; mat. zincd steel; flange DN 50 PN 16
4	M16 x 65 mm; mat. stainless steel 1.4301; flange DN 50 PN 16
A	5/8" x 83; mat. zincd steel A193B7; fange 2" ANSI 150 lbs
B	5/8" x 83; mat. stainless steel A193B8 A1948M; flange 2" ANSI 150 lbs
C	Bolts & nuts PTFE coated (only DN 50 or 2")
<b>9. Additional bracket welded to the float pipe</b>	
0	without
H	Bracket
<b>10. Float pipe seamless</b>	
0	without
S	64 x 2 mm seamless
<b>11. Float</b>	
E8C8VY	50,8x255; material: PVDF; pressure max. 16 bar; min. density of fluid: 0,85 kg/dm <sup>3</sup>
B8C4VY	52 x 150 material: Titan/PTFE-coated; pressure max.. 16 bar; min. density of fluid: 0,902 kg/dm <sup>3</sup>
E8C4VY	50,8x255; material: Titan/PTFE-coated; pressure max. 16 bar; min. density of fluid: 0,0,6873 kg/dm <sup>3</sup>

1	2	3	4	5	6	7	8	9	10	11				
ITA-3.8	L= mm										8	C	V	Y

### 3.6.1 ITA-4

Characteristics: PN 16 / Float pipe and flange material 1.4404

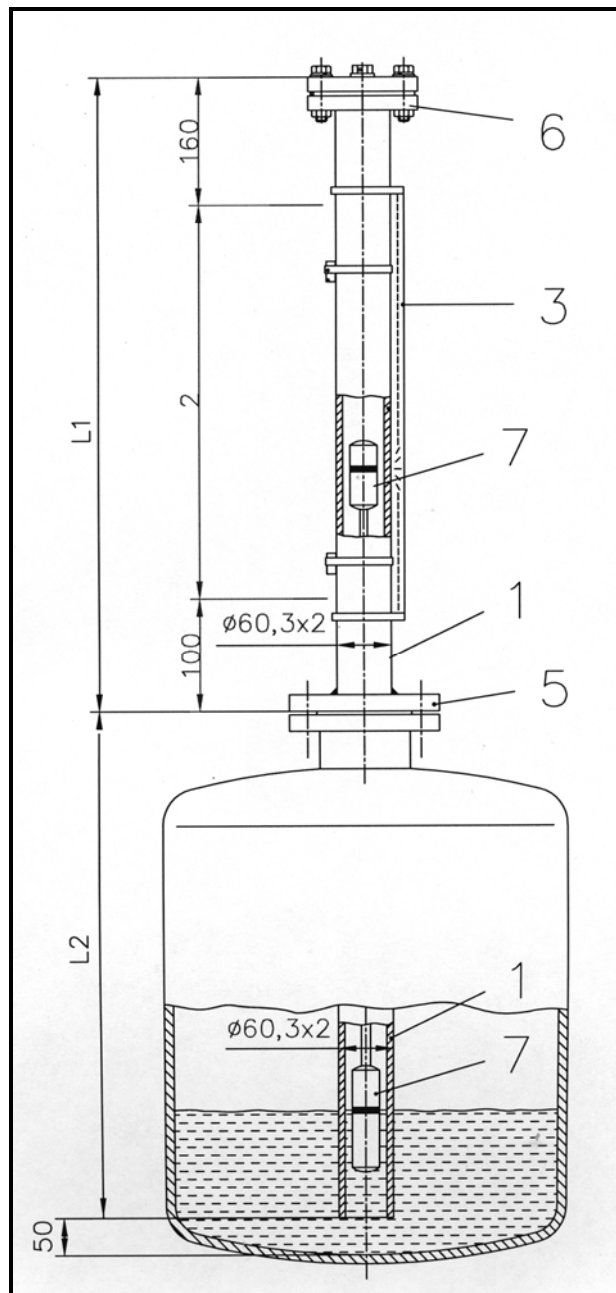

Parts drawing ITA-4

**Key:**

- 1 Float pipe welded Dimensions 60,3 x 2 mm
- 2 Measuring length
- 3 Design (indication rail)
- 5 Process connection on tank
- 6 Follower magnet guide tube topside finish
- 7 Float with rod and follower magnet

<b>Technical specification magnetic level gauge type ITA-4</b>
--

Principle	:	Communicating tubes with magnetic float
Mounting position	:	Top of tank
Measuring range	:	<b>max. 2750 mm</b> (depending on fluid's density)
Pipe diameter	:	<b>60,3 x 2 mm welded, necking connections</b>
Process connection	:	to specify: <b>Flanges DN50 PN16 or 2"150#</b>
Drain/vent connections	:	<b>Plugged R½"</b>
Pipe material	:	<b>1.4404</b> , Hastelloy C4 (2.4610), Inconel 625 (2.4856), Inconel 825 (2.4856), Titanium (3.7035), other materials available on request.
Flange material	:	as pipe material
Float material	:	<b>1.4404</b> , Titanium, Titanium/E-CTFE (Halar)-coated
Operation temperature	:	-50...+400 °C
Operation pressure	:	max. 16 bar
Operation density	:	min. 0,68 kg/dm <sup>3</sup>
Bolts & Nuts	:	<b>CS</b> SS
Gasket	:	<b>PTFE up to 100 °C</b> <b>Klingersil up to 175 °C</b> <b>Graphit spiral wound up to 400 °C</b>
Indication rail	:	<b>Makrolon up to 120 °C</b> Aluminium up to 400 °C 1.4301 up to 400 °C
Float types	:	Cylindrical, sealed type, with rod

**Base equipment printed in bold letters!**



### 3.6.2 ITA-4.0

Characteristics: PN 16 / Float pipe: 1.4404; Flanges: CS

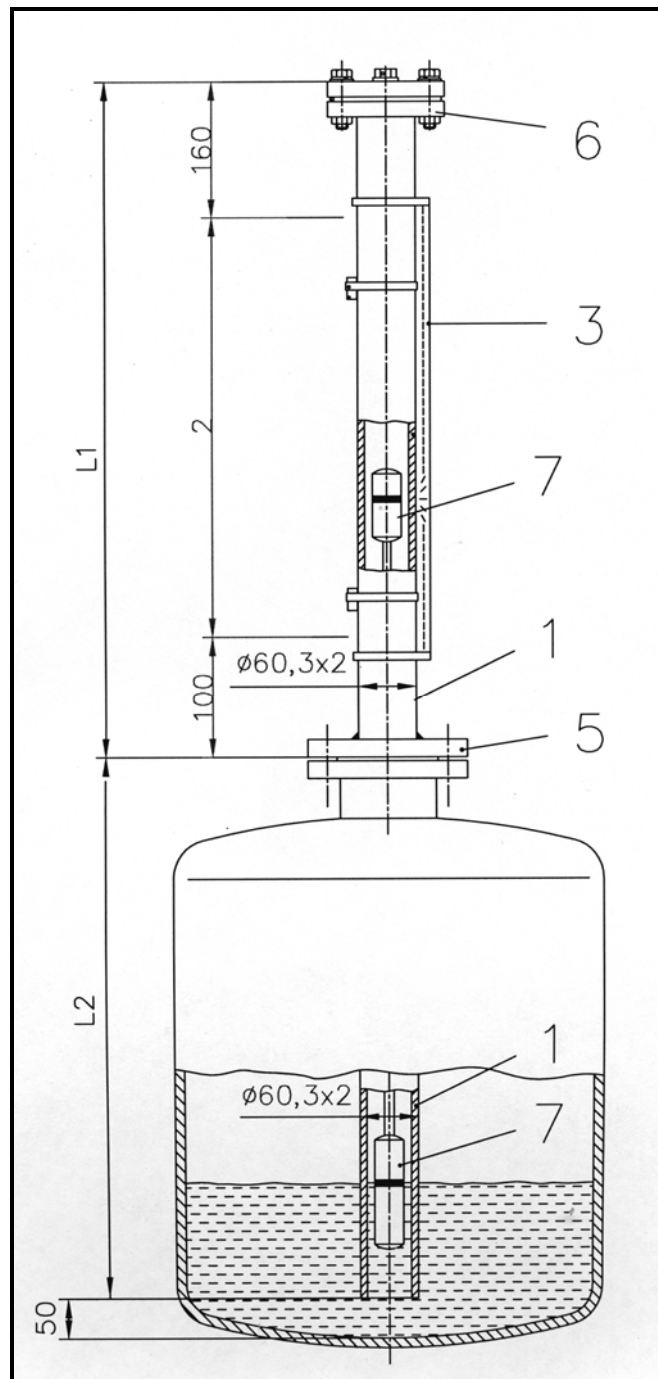

Parts drawing ITA-4.0

**Key:**

- 1 Float pipe welded Dimensions 60,3 x 2 mm
- 2 Measuring length
- 3 Design (indication rail)
- 5 Process connection on tank
- 6 Follower magnet guide tube topside finish
- 7 Float with rod and follower magnet

### Technical specifications magnetic level gauge type ITA-4.0

Principle	:	Communicating tubes with magnetic float
Mounting position	:	Top of tank
Measuring range	:	<b>max. 2750 mm</b> (depending on fluid's density)
Pipe diameter	:	<b>60,3 x 2 mm welded, necking connections</b>
Process connection	:	to specify: <b>Flanges DN50 PN16 or 2"150#</b>
Drain/vent connections	:	<b>Plugged R½"</b>
Pipe material	:	<b>1.4404</b> , Hastelloy C4 (2.4610), Inconel 625 (2.4856), Inconel 825 (2.4856), Titanium (3.7035), other materials available on request.
Flange material	:	CS
Float material	:	<b>1.4404</b> , Titanium, Titanium/E-CTFE (Halar)-coated
Operation temperature	:	-50...+400 °C
Operation pressure	:	max. 16 bar
Operation density	:	min. 0,68 kg/dm <sup>3</sup>
Bolts & Nuts	:	<b>CS</b> SS
Gasket	:	<b>PTFE up to 100 °C</b> <b>Klingersil up to 175 °C</b> <b>Graphit spiral wound up to 400 °C</b>
Indication rail	:	<b>Makrolon up to 120 °C</b> Aluminium up to 400 °C 1.4301 up to 400 °C
Float types	:	Cylindrical, sealed type, with rod

**Base equipment printed in bold letters!**

**Order codes for magnetic level gauge type ITA-4 and ITA-4.0**

Code	Description
<b>ITA-4 ITA-4.0</b>	<b>1. Float pipe welded Dimensions 60,3 x 2 mm</b>
	<b>2. Measuring length</b>
<b>L</b>	Measuring length in mm ( max. 2750 mm, depending on the density of the fluid)
	<b>3. Design</b>
<b>0</b>	without indication rail, each 100 mm
<b>1</b>	Indication rail material: Makrolon, max. 120 °C fluid temperature
<b>2</b>	Indication rail material: Aluminium, max. 400 °C fluid temperature
<b>3</b>	Indication rail material: 1.4401, max. 400 °C fluid temperature
	<b>4. Two-parts-construction</b>
<b>0</b>	without
<b>1</b>	Connection of the follower magnet guide tube DN50 PN16
<b>2</b>	Connection of the follower magnet guide tube 2" ANSI 150 lbs RF
	<b>5. Process connection on tank</b>
<b>1</b>	Flange DN 50/PN 16
<b>2</b>	Flange DN 80/PN 16
<b>3</b>	Flange DN 100/PN 16
<b>4</b>	Flange DN 125/PN 16
<b>5</b>	Flange DN 150/PN 16
<b>6</b>	Flange DN 200/PN 16
<b>A</b>	Flange 2" ANSI/150 lbs
<b>B</b>	Flange 3" ANSI/150 lbs
<b>C</b>	Flange 4" ANSI/150 lbs
<b>D</b>	Flange 5" ANSI/150 lbs
<b>E</b>	Flange 6" ANSI/150 lbs
<b>F</b>	Flange 8" ANSI/150 lbs
	<b>5.1 Surface of the process connection on tank</b>
<b>A</b>	Standard- Surface Form C
<b>B</b>	Standard-Surface RF
<b>C</b>	Surface Form D Rz=40
<b>D</b>	Surface Form E Rz=16
<b>E</b>	Surface RFSF (smooth finished)
<b>F</b>	Surface groove (DIN 2512)
<b>G</b>	Surface groove large
<b>H</b>	Surface Feder (DIN 2512)
<b>K</b>	Surface tongue-large
	<b>6. Follower magnet guide tube topside finish</b>
<b>1</b>	Flange with blind flange DN32 PN 16
<b>2</b>	Flange with blind flange DN50 PN 16
<b>A</b>	Flange with blind flange 1 1/4" ANSI 150 lbs
<b>B</b>	Flange with blind flange 2" ANSI 150 lbs



### 3.7.1 ITA-4.1

Characteristics: PN 16 / Float pipe and flange material 1.4404

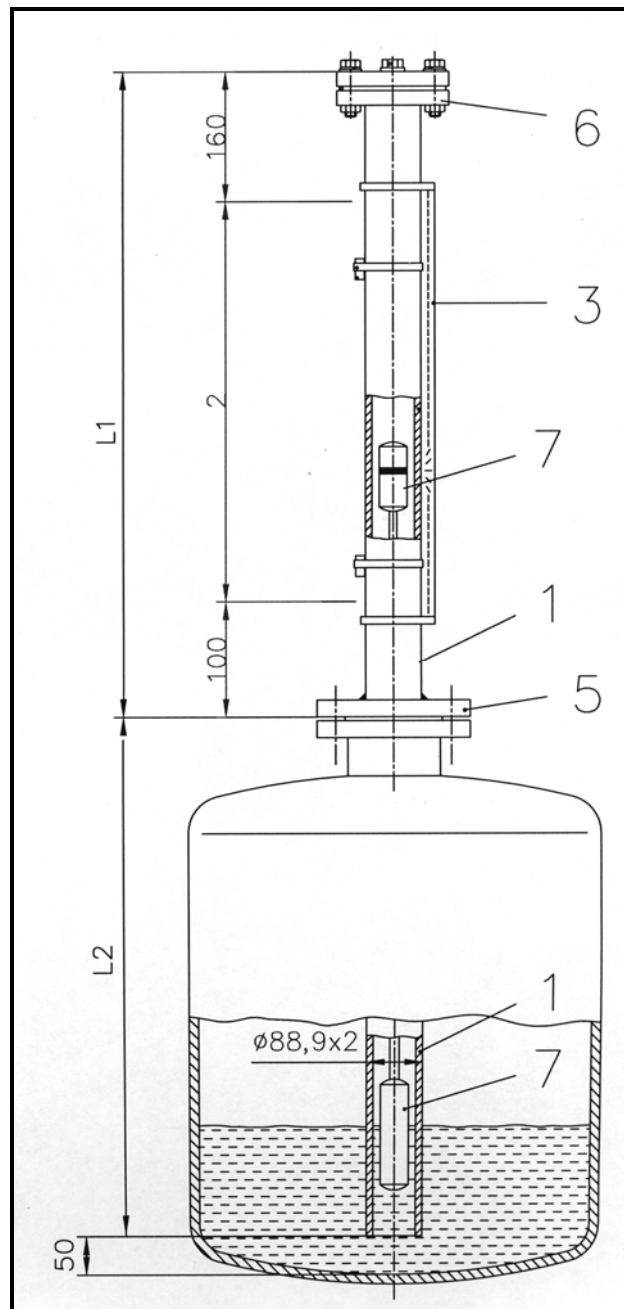

Parts drawing ITA-4.1

**Key:**

- 1 Float pipe welded Dimensions 88,9 x 2 mm
- 2 Measuring length
- 3 Design (indication rail)
- 5 Process connection on tank
- 6 Follower magnet guide tube topside finish
- 7 Float with rod and follower magnet

### Magnetic level gauge type ITA-4.1

Principle	:	Communicating tubes with magnetic float
Mounting position	:	Top of tank
Measuring range	:	<b>max. 2750 mm</b> (depending on fluid's density)
Pipe diameter	:	<b>88,9 x 2 mm welded, necking connections</b>
Process connection	:	to specify: <b>Flanges DN80 PN16 or 4"150#</b>
Drain/vent connections	:	<b>Plugged R½"</b>
Pipe material	:	<b>1.4404</b> , Hastelloy C4 (2.4610), Inconel 625 (2.4856), Inconel 825 (2.4856), Titanium (3.7035), other materials available on request.
Flange material	:	as pipe material
Float material	:	<b>1.4404</b> , Titanium, Titanium/E-CTFE (Halar)-coated
Operation temperature	:	-50...+400 °C
Operation pressure	:	atmospheric
Operation density	:	min. 0,35 kg/dm <sup>3</sup>
Bolts & Nuts	:	<b>CS</b> SS
Gasket	:	<b>PTFE up to 100 °C</b> <b>Klingersil C4400 up to 175 °C</b> <b>Graphit spiral wound up to 400 °C</b>
Indication rail	:	<b>Makrolon up to 120 °C</b> Aluminium up to 400 °C 1.4301 up to 400 °C
Float types	:	Cylindrical, sealed type, with rod

**Base equipment printed in bold letters!**

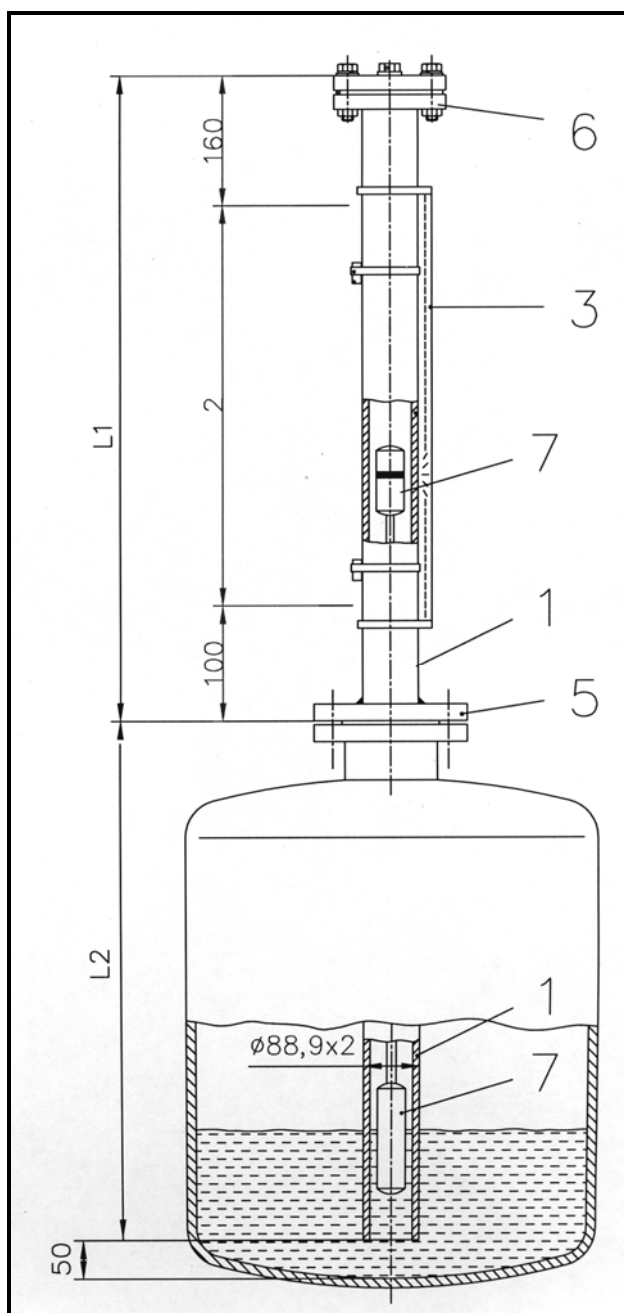
**3.7.2 ITA-4.1.0****Characteristics: PN 16 / Float pipe: 1.4404; Flanges: CS**

Parts drawing ITA-4.1

**Key:**

- 1 Float pipe welded Dimensions 88,9 x 2 mm
- 2 Measuring length
- 3 Design (indication rail)
- 5 Process connection on tank
- 6 Follower magnet guide tube topside finish
- 7 Float with rod and follower magnet

<b>Technical specifications magnetic level gauge type ITA-4.1.0</b>
---

Principle	:	Communicating tubes with magnetic float
Mounting position	:	Top of tank
Measuring range	:	<b>max. 2750 mm</b> (depending on fluid's density)
Pipe diameter	:	<b>88,9 x 2 mm welded, necking connections</b>
Process connection	:	to specify: <b>Flanges DN80 PN16 or 4"150#</b>
Drain/vent connections	:	<b>Plugged R½"</b>
Pipe material	:	<b>1.4404</b> , Hastelloy C4 (2.4610), Inconel 625 (2.4856), Inconel 825 (2.4856), Titanium (3.7035), other materials available on request.
Flange material	:	CS
Float material	:	<b>1.4404</b> , Titanium, Titanium/E-CTFE (Halar)-coated
Operation temperature	:	-50...+400 °C
Operation pressure	:	atmospheric
Operation density	:	min. 0,35 kg/dm <sup>3</sup>
Bolts & Nuts	:	<b>CS</b> SS
Gasket	:	<b>PTFE up to 100 °C</b> <b>Klingsil C4400 up to 175 °C</b> <b>Graphit spiral wound up to 400 °C</b>
Indication rail	:	<b>Makrolon up to 120 °C</b> Aluminium up to 400 °C 1.4301 up to 400 °C
Float types	:	Cylindrical, sealed type, with rod

**Base equipment printed in bold letters!**



<b>Order codes for magnetic level gauge type ITA-4.1 and ITA-4.1.0</b>
--

Code	Description
<b>ITA-4.1 ITA-4.1.0</b>	<b>1. Float pipe welded 88,9 x 2 mm</b>
	<b>2. Measuring length</b>
<b>L</b>	Measuring length in mm ( max. 2750 mm, depending on the density of the fluid)
	<b>3. Design</b>
<b>0</b>	without indication rail
<b>1</b>	Indication rail material: Makrolon, max. 120 °C fluid temperature
<b>2</b>	Indication rail material: Aluminium, max. 400 °C fluid temperature
<b>3</b>	Indication rail material: 1.4401, max. 400 °C fluid temperature
	<b>4. Two-parts-construction</b>
<b>0</b>	without
<b>1</b>	Connection of the follower magnet guide tube DN50 PN16
<b>2</b>	Connection of the follower magnet guide tube 2" ANSI 150 lbs RF
	<b>5. Process connection on tank</b>
<b>1</b>	Flange DN 80/PN 16
<b>2</b>	Flange DN 100/PN 16
<b>3</b>	Flange DN 125/PN 16
<b>4</b>	Flange DN 150/PN 16
<b>5</b>	Flange DN 200/PN 16
<b>A</b>	Flange 3" ANSI/150 lbs
<b>B</b>	Flange 4" ANSI/150 lbs
<b>C</b>	Flange 5" ANSI/150 lbs
<b>D</b>	Flange 6" ANSI/150 lbs
<b>E</b>	Flange 8" ANSI/150 lbs
	<b>5.1 Surface of the process connection on tank</b>
<b>A</b>	Standard- Surface Form C
<b>B</b>	Standard-Surface RF
<b>C</b>	Surface Form D Rz=40
<b>D</b>	Surface Form E Rz=16
<b>E</b>	Surface RFSF (smooth finished)
<b>F</b>	Surface groove (DIN 2512)
<b>G</b>	Surface groove large
<b>H</b>	Surface Feder (DIN 2512)
<b>K</b>	Surface tongue-large
	<b>6. Follower magnet guide tube topside finish</b>
<b>1</b>	Flange with blind flange DN32 PN 16
<b>A</b>	Flange with blind flange 1 1/2" ANSI 150 lbs

**Order codes for magnetic level gauge type ITA-4.1 and ITA-4.1.0 (Continuation)**

Code	Description
<b>F9C2R</b>	<b>7. Float type NF3, material: Titanium incl. rod: Titanium diam. 80 mm; L = 270 mm; min. density 0,35 kg/dm<sup>3</sup>; max. pressure 1 bar</b>
	<b>Measuring length:                      Density(min.)</b>
<b>A</b>	500 mm                                      0,35 kg/dm <sup>3</sup>
<b>B</b>	750 mm                                      0,36 kg/dm <sup>3</sup>
<b>C</b>	1000 mm                                    0,37 kg/dm <sup>3</sup>
<b>D</b>	1250 mm                                    0,39 kg/dm <sup>3</sup>
<b>E</b>	1500 mm                                    0,41 kg/dm <sup>3</sup>
<b>F</b>	1750 mm                                    0,44 kg/dm <sup>3</sup>
<b>H</b>	2000 mm                                    0,46 kg/dm <sup>3</sup>
<b>K</b>	2250 mm                                    0,48 kg/dm <sup>3</sup>
<b>L</b>	2500 mm                                    0,50 kg/dm <sup>3</sup>
<b>M</b>	2750 mm                                    0,52 kg/dm <sup>3</sup>

<b>1</b>	<b>2</b>	<b>3</b>	<b>4</b>	<b>5</b>	<b>6</b>	<b>7</b>						
ITA-4.1	L=                      mm					F	9	C	2	R		Y

<b>1</b>	<b>2</b>	<b>3</b>	<b>4</b>	<b>5</b>	<b>6</b>	<b>7</b>						
ITA-4.1.0	L=                      mm					F	9	C	2	R		Y

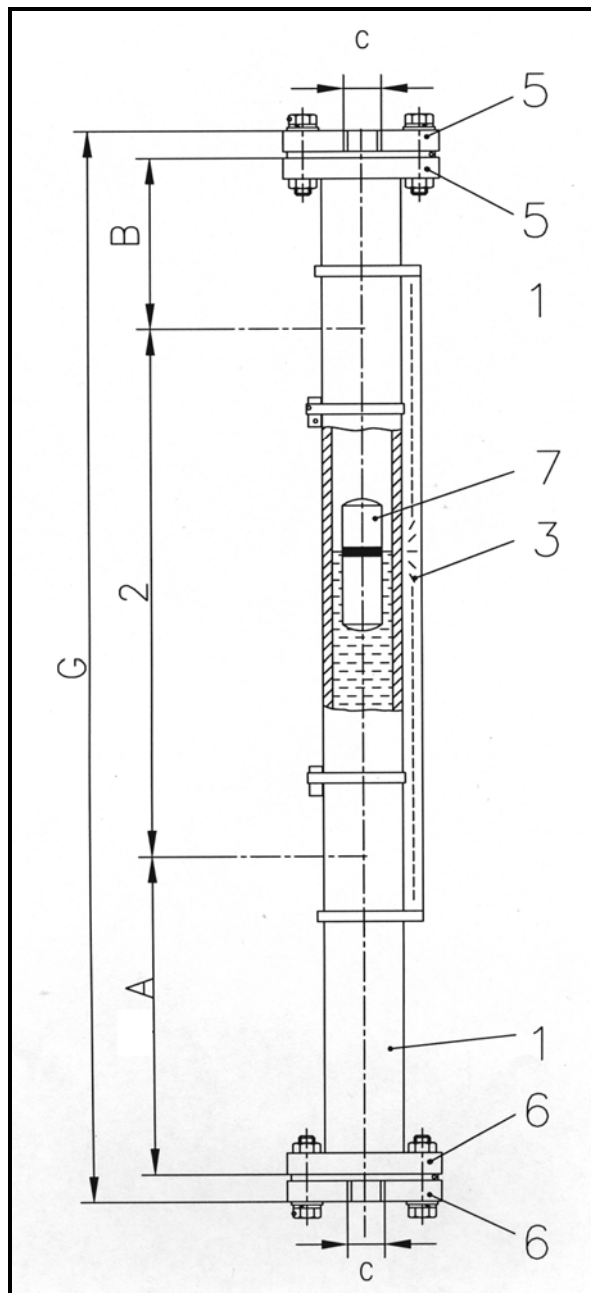
**3.8.1 ITA-5****Characteristics: PN 16 / 40 Float pipe and flange material 1.4404**

Parts drawing ITA-5

**Key:**

- 1 Float pipe welded Dimensions 60,3 x 2 mm
- 2 Distance between process connections
- 3 Design (indication rail)
- 5 Process connection topside
- 6 Process connection bottom side
- 7 Float

**Technical specifications magnetic level gauge type ITA-5**

Principle	:	Communicating tubes with magnetic float
Mounting position	:	Vertical
Measuring range	:	<b>max. 5000 mm (one part)</b> > 5000 mm 2- or multipart
Pipe diameter	:	<b>60,3 x 2 mm welded, necking connections</b> 2" Sch10 60,3 x (2-8,7 mm) seamless (depending on pressure rating)
Process connection	:	to specify: <b>R1/2" threaded (up to PN40)</b> <b>Welding or threaded stud</b> Flanged DN15-DN50 (1/2"-2")
Pipe material	:	<b>1.4404</b> , Hastelloy C4 (2.4610), Inconel 625 (2.4856), Inconel 825 (2.4856), Titanium (3.7035), other materials available on request.
Flange material	:	as pipe material
Float material	:	<b>1.4404</b> , Titanium, Titanium/E-CTFE (Halar)-coated
Operation temperature	:	-50...+400 °C
Operation pressure	:	<b>max. 16 bar</b> up to 320 bar
Operation density	:	min. 0,3371 kg/dm <sup>3</sup>
Bolts & Nuts	:	<b>CS</b> SS
Gasket	:	<b>PTFE up to 100 °C / PN40</b> <b>Klingersil C4400 up to 175 °C / PN40</b> <b>Graphit spiral wound up to 400 °C</b>
Indication rail	:	<b>Makrolon up to 120 °C</b> Aluminium up to 400 °C 1.4301 up to 400 °C
Float types	:	Cylindrical, sealed type or vented type (depending on pressure rating)
Dimensions	:	- A= 240* - B= 130 (up to PN64) - <b>C= R1/2" (up to PN40)</b> <b>1/2" NPT (all pressure ratings)</b>

**Base equipment printed in bold letters!**

\*depending on the density the scale A can be enlarged

### 3.8.2 ITA-5.0

Characteristics: PN 16 / 40 Float pipe: 1.4404; Flanges: CS

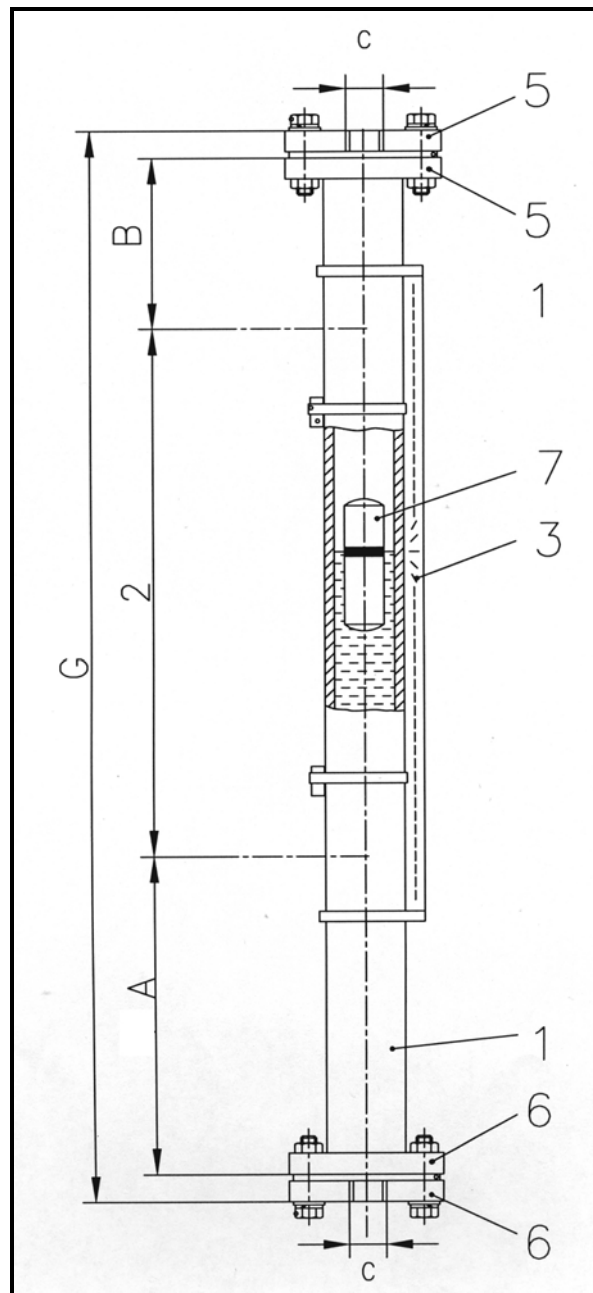

Parts drawing ITA-5.0

**Key:**

- 1 Float pipe welded Dimensions 60,3 x 2 mm
- 2 Distance between process connections
- 3 Design (indication rail)
- 5 Process connection topside
- 6 Process connection bottom side
- 7 Float

**Technical specifications magnetic level gauge type ITA-5.0**

Principle	:	Communicating tubes with magnetic float
Mounting position	:	Vertical
Measuring range	:	<b>max. 5000 mm (one part)</b> > 5000 mm 2- or multipart
Pipe diameter	:	<b>60,3 x 2 mm welded, necking connections</b> 2" Sch10 60,3 x (2-8,7 mm) seamless (depending on pressure rating)
Process connection	:	to specify: <b>R1/2" threaded (up to PN40)</b> <b>Welding or threaded stud</b> Flanged DN15-DN50 (1/2"-2")
Pipe material	:	<b>1.4404</b> , Hastelloy C4 (2.4610), Inconel 625 (2.4856), Inconel 825 (2.4856), Titanium (3.7035), other materials available on request.
Flange material	:	<b>CS</b>
Float material	:	<b>1.4404</b> , Titanium, Titanium/E-CTFE (Halar)-coated
Operation temperature	:	-50...+400 °C
Operation pressure	:	<b>max. 16 bar</b> up to 320 bar
Operation density	:	min. 0,3371 kg/dm <sup>3</sup>
Bolts & Nuts	:	<b>CS</b> SS
Gasket	:	<b>PTFE up to 100 °C / PN40</b> <b>Klingersil C4400 up to 175 °C / PN40</b> <b>Graphit spiral wound up to 400 °C</b>
Indication rail	:	<b>Makrolon up to 120 °C</b> Aluminium up to 400 °C 1.4301 up to 400 °C
Float types	:	Cylindrical, sealed type or vented type (depending on pressure rating)
Dimensions	:	- A= 240* - B= 130 (up to PN64) - <b>C= R1/2" (up to PN40)</b> <b>1/2" NPT (all pressure ratings)</b>

**Base equipment printed in bold letters!**

\*depending on the density the scale A can be enlarged

<b>Order codes for magnetic level gauge type ITA-5 and ITA-5.0</b>
--

Code	Description
<b>ITA-5 ITA-5.0</b>	<b>1. Float pipe welded Dimensions 60,3x2 mm</b>
	<b>2. Distance between process connections</b>
<b>L</b>	Distance between process connections in mm
	<b>3. Design</b>
<b>0</b>	without indication rail
<b>1</b>	Indication rail material Makrolon, max. 120 °C
<b>2</b>	Indication rail material Aluminium, max. 400 °C
<b>3</b>	Indication rail material 1.4401, max. 400 °C
	<b>4. Distance between process connections &gt; 5000 mm</b>
<b>A</b>	Dist. betw. process connections < 5000 mm, without connection flanges
<b>B</b>	Dist. betw. process connections > 5000 mm, with connection flanges DN 32 PN 16
	<b>5. Process connection topside</b>
<b>Y</b>	Welding connection (please specify)
<b>Z</b>	Female thread (please specify)
<b>1</b>	Flange with blind flange DN 32 PN 16
	<b>5.1 Surface of process connection topside</b>
<b>0</b>	without
<b>A</b>	Standard-Surface Form C
<b>B</b>	Standard-Surface RF
<b>C</b>	Surface Form D Rz=40
<b>D</b>	Surface Form E Rz=16
<b>E</b>	Surface RFSF (smooth finished)
<b>F</b>	Surface groove (DIN2512)
<b>G</b>	Surface groove large
<b>H</b>	Surface tongue (DIN2512)
<b>K</b>	Surface tongue-large
	<b>5.2 Bolts &amp; Nuts process connection topside</b>
<b>0</b>	without
<b>1</b>	M16 x 65 mm; mat 5.6 zincd; flange DN 32 PN 16 DIN 931
<b>2</b>	M16 x 80 mm; mat. A2-70; flange DN 32 PN 16 DIN 2510
<b>3</b>	M16 x 65 mm; mat. 5.6 zincd; flange DN 32 PN 40 DIN 931
<b>4</b>	M16 x 80 mm; mat. A2-70; flange DN 32 PN 40 DIN 2510
<b>5</b>	M16 x 65 mm; mat. 5.6 zincd; flange DN 50 PN 16 DIN 931
<b>6</b>	M16 x 80 mm; mat. A2-70; flange DN 50 PN 16 DIN 2510
<b>7</b>	M16 x 65 mm; mat. 5.6 zincd; flange DN 50 PN 40 DIN 931
<b>8</b>	M16 x 80 mm; mat. A2-70; flange DN 50 PN 40 DIN 2510
	<b>6. Process connection bottom side</b>
<b>Y</b>	Welding connection (please specify)
<b>Z</b>	Female thread (please specify)
<b>A</b>	Flange with blind flange DN 50 PN 16

**Order codes for magnetic level gauge type ITA-5 and ITA-5.0 (Continuation)**

Code	Description
<b>6.1 Surface of process connection bottom side</b>	
0	without
A	Standard-Surface Form C
B	Standard-Surface RF
C	Surface Form D Rz=40
D	Surface Form E Rz=16
E	Surface RFSF (smooth finished)
F	Surface groove (DIN2512)
G	Surface groove large
H	Surface tongue (DIN2512)
K	Surface tongue-large
<b>6.2 Bolts &amp; Nuts process connection bottom side</b>	
0	without
1	M16 x 65 mm; mat 5.6 zined; flange DN 32 PN 16 DIN 931
2	M16 x 80 mm; mat. A2-70; flange DN 32 PN 16 DIN 2510
3	M16 x 65 mm; mat. 5.6 zined; flange DN 32 PN 40 DIN 931
4	M16 x 80 mm; mat. A2-70; flange DN 32 PN 40 DIN 2510
5	M16 x 65 mm; mat. 5.6 zined; flange DN 50 PN 16 DIN 931
6	M16 x 80 mm; mat. A2-70; flange DN 50 PN 16 DIN 2510
7	M16 x 65 mm; mat. 5.6 zined; flange DN 50 PN 40 DIN 931
8	M16 x 80 mm; mat. A2-70; flange DN 50 PN 40 DIN 2510
<b>7. Floats for pessure rating PN16 (150 lbs)</b>	
<b>max. 16 bar / Float sealed</b>	
F8C1SY	52x270 mm; material 1.4571; min. density: 0,7374 kg/dm <sup>3</sup>
F7C2SY	50,8x270 mm; material Titanium; min. density: 0,5723 kg/dm <sup>3</sup>
B8C1SY	52x150 mm; material 1.4571; min. density: 1,2346 kg/dm <sup>3</sup>
B7C2SY	50,8x150 mm; material Titanium; min. density: 0,9646 kg/dm <sup>3</sup>
G7C2SY	50,8x330 mm; material Titanium; min. density: 0,4955 kg/dm <sup>3</sup>
H7C2SY	50,8x430 mm; material Titanium; min. density: 0,4358 kg/dm <sup>3</sup>
K7C2SY	50,8x530 mm; material Titanium; min. density: 0,4017 kg/dm <sup>3</sup>
L7C2SY	50,8x630 mm; material Titanium; min. density: 0,3761 kg/dm <sup>3</sup>
F8C3SY	52x270 mm; material Titanium/E-CTFE-coated; min. density: 0,6873 kg/dm <sup>3</sup>
F8C5SY	52x270 mm; material Hastelloy C4; min. density: 0,7510 kg/dm <sup>3</sup>
<b>Floats for pessure rating PN 40 (300 lbs)</b>	
<b>max. 20 bar / Float sealed</b>	
F8D2SY	52x270 mm; material Titanium; min. density: 0,7374 kg/dm <sup>3</sup>
F7D2SY	50,8x270 mm; material Titanium; min. density: 0,5723 kg/dm <sup>3</sup>
<b>max. 24 bar / Float sealed</b>	
F8E5SY	52x270 mm; material Hastelloy C4; min. density: 0,8 kg/dm <sup>3</sup>



**Order codes for magnetic level gauge type ITA-5 and ITA-5.0 (Continuation)**

Code	Description
	<b>max. 40 bar / Float sealed</b>
<b>F8H1SY</b>	52x270 mm; material 1.4571; min. density: 1,0 kg/dm <sup>3</sup>
<b>F7H2SY</b>	50,8x270 mm; material Titanium; min. density: 0,6391 kg/dm <sup>3</sup>
<b>B7H2SY</b>	50,8x150 mm; material Titanium; min. density: 1,1007 kg/dm <sup>3</sup>
<b>G7H2SY</b>	50,8x330 mm; material Titanium; min. density: 0,5694 kg/dm <sup>3</sup>
<b>H7H2SY</b>	50,8x430 mm; material Titanium; min. density: 0,53 kg/dm <sup>3</sup>
<b>K7H2SY</b>	50,8x530 mm; material Titanium; min. density: 0,4463 kg/dm <sup>3</sup>
<b>L7H2SY</b>	50,8x630 mm; material Titanium; min. density: 0,4370 kg/dm <sup>3</sup>
<b>F8H3SY</b>	52x270 mm; material Titanium/E-CTFE-coated; min. density: 0,7647 kg/dm <sup>3</sup>

1	2	3	4	5	6	7				S	Y	
ITA-5	L=                    mm											

1	2	3	4	5	6	7				S	Y	
ITA-5.0	L=                    mm											

**3.9 ITA-5.5**

Characteristics: PN 16 Float pipe and flange material 1.4404

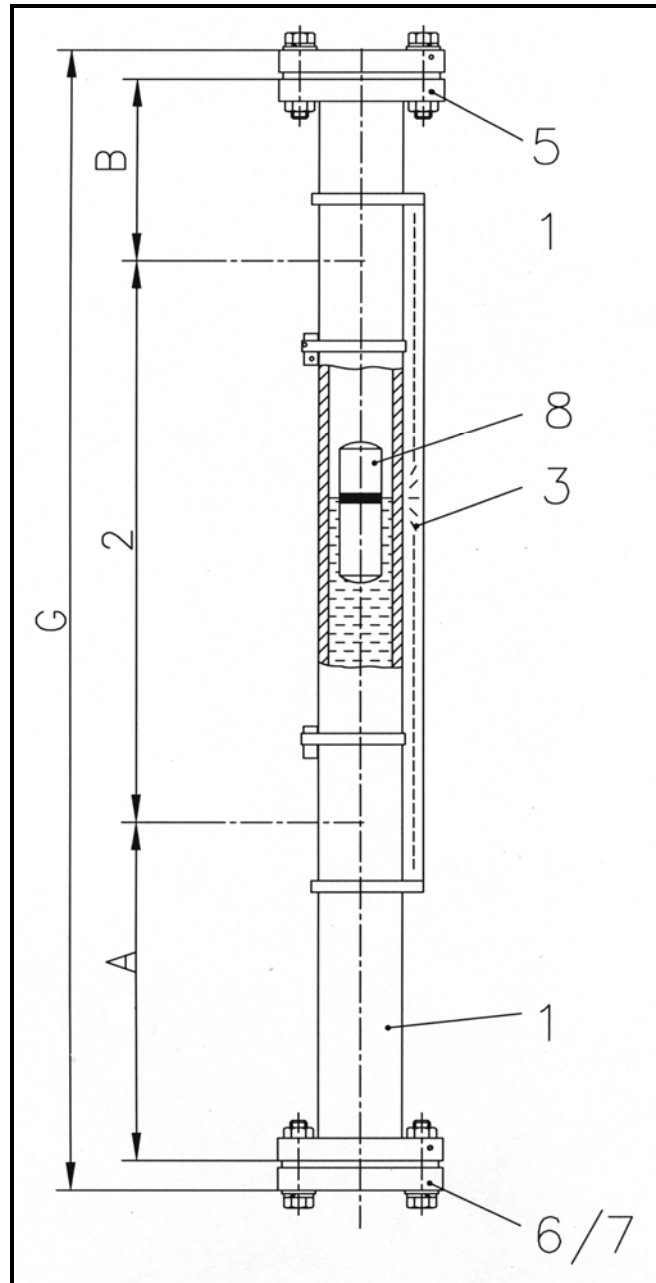

Parts drawing ITA-5.5

**Key:**

- 1 Float pipe welded Dimensions 60,3 x 2 mm
- 2 Distance between process connections
- 3 Design (indication rail)
- 5 Process connection topside
- 6 Float removal flange
- 7 Process connection bottom side
- 8 Float

### Technical specifications magnetic level gauge type ITA-5.5

Principle	:	Communicating tubes with magnetic float
Mounting position	:	Vertical
Measuring range	:	<b>max. 3100 mm (one part, total length 3500 mm)</b> > 3500 mm 2- or multipart
Pipe size	:	<b>60,3 x 2 mm seamless</b>
Process connection	:	Flanged DN20-DN50 (3/4"-2")
Pipe material	:	<b>1.4404, wetted parts E-CTFE-coated (Halar)</b>
Flange material	:	<b>As pipe material</b>
Float material	:	<b>Titanium/E-CTFE (Halar)-coated</b>
Operation temperature	:	-50...+150 °C
Operation pressure	:	<b>max. 16 bar</b>
Operation density	:	min. 0,5645 kg/dm <sup>3</sup>
Bolts & Nuts	:	<b>CS</b> SS
Gasket	:	<b>PTFE up to 100 °C</b> <b>Klingertop-chem-200 up to 260 °C</b>
Indication rail	:	<b>Makrolon up to 120 °C</b> Aluminium up to 400 °C 1.4301 up to 400 °C
Float types	:	Cylindrical, sealed type
Dimensions	:	- A= 240* - B= 130 (up to PN64)

**Base equipment printed in bold letters!**

**Order codes for magnetic level gauge type ITA-5.5**

Code	Description
<b>ITA-5.5</b>	<b>1. Float pipe seamless 60,3x2 mm</b>
	<b>2. Distance between process connections</b>
<b>L</b>	Distance between process connections in mm
	<b>3. Design</b>
<b>0</b>	without indication rail
<b>1</b>	Indication rail material Makrolon, max. 120 °C
<b>2</b>	Indication rail material Aluminium, max. 400 °C
<b>3</b>	Indication rail material 1.4401, max. 400 °C
	<b>4. Distance between process connections &gt; 3500 mm</b>
<b>0</b>	Dist. betw. process connections < 3500 mm, without connection flanges
<b>A</b>	Dist. betw. process connections > 3500 mm, with connection flanges DN 32 PN 16
<b>B</b>	Dist. betw. process connections > 3500 mm, with connection flanges 1 1/4"ANSI150lbs
	<b>5. Process connection topside</b>
<b>1</b>	Flange DN50 PN16
<b>A</b>	Flange 2" ANSI 150 lbs
	<b>6. Float removal flange</b>
<b>1</b>	Flange DN50 PN16
<b>A</b>	Flange 2" ANSI 150 lbs
	<b>7. Process connection downside on concentric reducer (X-ray-testing)</b>
<b>1</b>	Flange DN 20 PN 16
<b>2</b>	Flange DN 25 PN 16
<b>3</b>	Flange DN 32 PN 16
<b>4</b>	Flange DN 40 PN 16
<b>5</b>	Flange DN 50 PN 16
<b>A</b>	Flange 3/4" ANSI 150 lbs
<b>B</b>	Flange 1" ANSI 150 lbs
<b>C</b>	Flange 1 1/4" ANSI 150 lbs
<b>D</b>	Flange 1 1/2" ANSI 150 lbs
<b>E</b>	Flange 2" ANSI 150 lbs
	<b>7.1 Bolts &amp; Nuts</b>
<b>1</b>	M16 x 65 mm, mat. 5.6 zincd DIN 931;Flange DN 50 PN 16
<b>2</b>	M16 x 80 mm, mat. A2-70 DIN 2510; Flange DN 50 PN 16
<b>A</b>	5/8" x 83 mm, mat. A193B7/A1942H zincd ANSI B16.5; Flange 2" 150 lbs
<b>B</b>	5/8" x 83 mm, mat. A193B7/A1942H PTFE-coated ANSI B16.5; Flange 2" 150 lbs
<b>C</b>	5/8" x 83 mm, mat. A193B8 / A1948M SS B16.5; Flansch 2" 150 lbs
	<b>8. Float</b>
<b>F8C3VY</b>	52x270 mm; material Titanium/E-CTFE-coated; min. density: 0,6873 kg/dm <sup>3</sup>
<b>B8C3VY</b>	52x150 mm; material Titanium/E-CTFE-coated; min. density: 0,902 kg/dm <sup>3</sup>

<b>1</b>	<b>2</b>	<b>3</b>	<b>4</b>	<b>5</b>	<b>6</b>	<b>7</b>	<b>8</b>					
ITA-5.5	L=	mm						8	C	3	V	Y

### 3.10.1 ITA-6

Characteristics: PN40 / Float pipe and flange material 1.4404

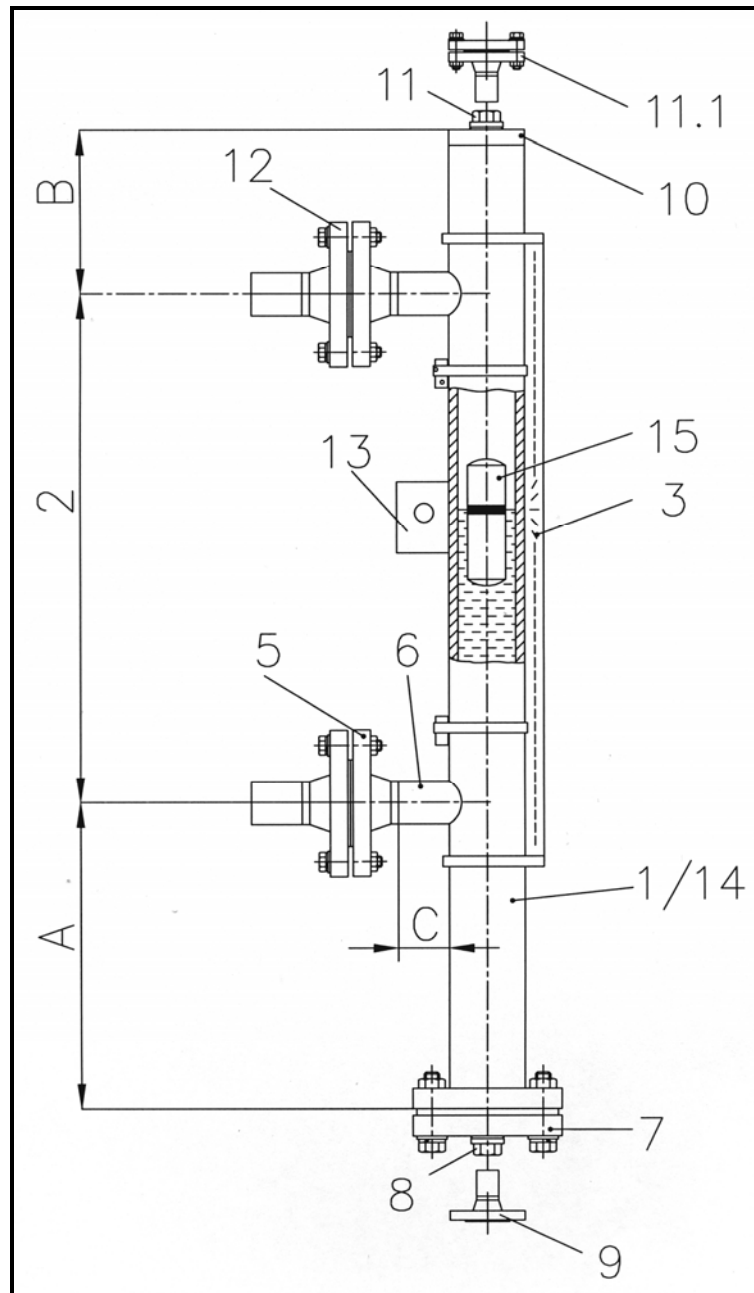

Parts drawing ITA-6

**Key:**

- |   |   |    |                               |
|---|---|----|-------------------------------|
| 1 | Float pipe welded Dimensions 60,3 x 2 mm                | 9  | Additional drain flange, open |
| 2 | c to c distance   | 10 | Float pipe top end finish     |
| 3 | Design (indication rail)                                | 11 | Vent plug                     |
| 5 | Process connection side/side                            | 12 | Counter flanges               |
| 6 | Side studs welded with T-pieces for 100 % X-ray testing | 13 | Additional bracket            |
| 7 | Float removal flange                                    | 14 | Float pipe seamless           |
| 8 | Drain plug  | 15 | Float                         |

**Technical specification magnetic level gauge type ITA-6**

Principle	:	Communicating tubes with magnetic float
Mounting position	:	vertical
Measuring range	:	<b>max. 5000 mm (one-part)</b> > 5000 mm 2- or multipart
Pipe diameter	:	<b>60,3 x 2 mm welded,</b> 60,3 x 2 mm seamless 2"Sch10 <b>necking connection</b> or buttweld with T-pieces
Process connection	:	to specify: <b>Flanges DN15-50 (1/2"-2"300#),</b> <b>Welding or threaded stud</b>
Drain/vent connections	:	<b>Plug R1/2"</b> (for more please see price list)
Pipe material	:	<b>1.4404</b> , 1.4435, 1.4539, Hastelloy C4 (2.4610), Inconel 625 (2.4856), Inconel 825 (2.4858), Titan (3.7035) Other materials also possible (on request)
Flange material	:	same as pipe material
Float material	:	<b>1.4404</b> Titan, Titan/E-CTFE-coated
Operation temperature	:	-50...+400 °C
Operation pressure	:	max. 40 bar
Operation density	:	min. 0,5723 kg/dm <sup>3</sup> * up to 20 bar process pressure min. 0,4370 kg/dm <sup>3</sup> up to 40 bar process pressure
Bolts & Nuts	:	A193/A194 B7/2H A193/A194 B8/8M CS hot dipped galvanized SS
Gasket	:	<b>PTFE up to 100 °C</b> <b>Klingsil C4400 up to 175 °C</b> <b>Graphit spiral wound up to 400 °C**</b>
Indication rail	:	<b>Makrolon up to 120 °C</b> Aluminium up to 400 °C 1.4301 up to 400 °C
Float types	:	Cylindrical, sealed type Length: - <b>270 mm</b> - 130 mm - 150 mm - 210 mm - 330 mm - 430 mm - 530 mm - 630 mm
Standard dimensions	:	- A = 240* - B = 130 - C = 40

**Base equipment printed in bold letters!**

\* for densities < 0,5723 kg/dm<sup>3</sup> enlarge the scale A

\*\* only with vent- and/or drain-flanges DN50 resp. 2"

### 3.10.2 ITA-6.0

Characteristics: PN40 / Float pipe: 1.4404 Flanges: CS

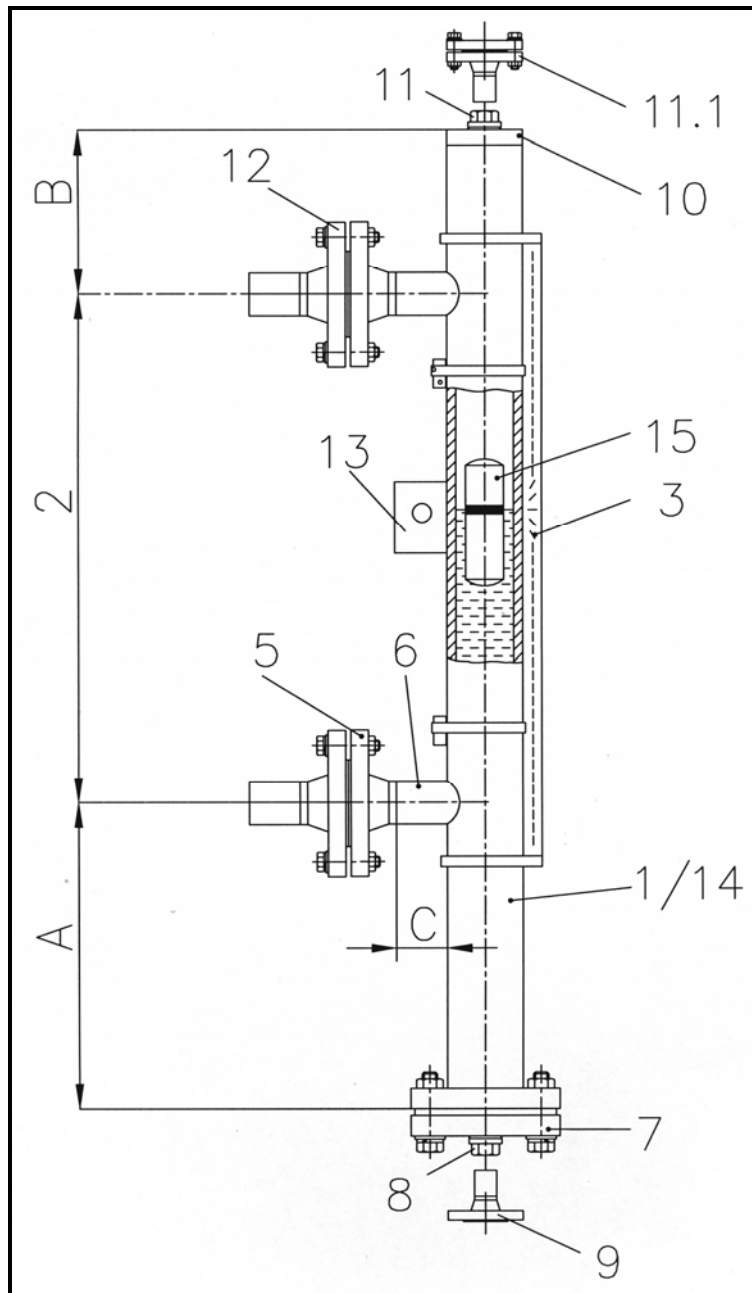

Parts drawing ITA-6.0

**Key:**

- |   |   |    |                               |
|---|---|----|-------------------------------|
| 1 | Float pipe welded Dimensions 60,3 x 2 mm                | 9  | Additional drain flange, open |
| 2 | c to c distance   | 10 | Float pipe top end finish     |
| 3 | Design (indication rail)                                | 11 | Vent plug                     |
| 5 | Process connection side/side                            | 12 | Counter flanges               |
| 6 | Side studs welded with T-pieces for 100 % X-ray testing | 13 | Additional bracket            |
| 7 | Float removal flange                                    | 14 | Float pipe seamless           |
| 8 | Drain plug  | 15 | Float                         |

**Technical specification magnetic level gauge type ITA-6.0**

Principle	:	Communicating tubes with magnetic float
Mounting position	:	vertical
Measuring range	:	<b>max. 5000 mm (one-part)</b> > 5000 mm 2- or multipart
Pipe diameter	:	<b>60,3 x 2 mm welded,</b> 60,3 x 2 mm seamless 2"Sch10 <b>necking connection</b> or buttweld with T-pieces
Process connection	:	to specify: <b>Flanges DN15-50 (1/2"-2"300#),</b> <b>Welding or threaded stud</b>
Drain/vent connections	:	<b>Plug R1/2"</b> (for more please see price list)
Pipe material	:	<b>1.4404</b> , 1.4435, 1.4539, Hastelloy C4 (2.4610), Inconel 625 (2.4856), Inconel 825 (2.4858), Titan (3.7035) Other materials also possible (on request)
Flange material	:	CS
Float material	:	<b>1.4404</b> Titan, Titan/E-CTFE-coated
Operation temperature	:	-50...+400 °C
Operation pressure	:	max. 40 bar
Operation density	:	min. 0,5723 kg/dm <sup>3</sup> * up to 20 bar process pressure min. 0,4370 kg/dm <sup>3</sup> up to 40 bar process pressure
Bolts & Nuts	:	A193/A194 B7/2H A193/A194 B8/8M CS hot dipped galvanized SS
Gasket	:	<b>PTFE up to 100 °C</b> <b>Klingsil C4400 up to 175 °C</b> <b>Graphit spiral wound up to 400 °C**</b>
Indication rail	:	<b>Makrolon up to 120 °C</b> Aluminium up to 400 °C 1.4301 up to 400 °C
Float types	:	Cylindrical, sealed type Length: - <b>270 mm</b> - 130 mm - 150 mm - 210 mm - 330 mm - 430 mm - 530 mm - 630 mm
Standard dimensions	:	- A = 240* - B = 130 - C = 40

**Base equipment printed in bold letters!**

\* for densities < 0,5723 kg/dm<sup>3</sup> enlarge the scale A

\*\* only with vent- and/or drain-flanges DN50 resp. 2"



**Order codes for magnetic level gauge type ITA-6 and ITA-6.0 (Continuation)**

Code	Description
<b>ITA-6 ITA-6.0</b>	<b>1. Float pipe welded Dimensions 60,3 x 2 mm</b>
	<b>2. c to c distance</b>
<b>L</b>	c to c distance in mm
	<b>3. Design</b>
<b>0</b>	without indication rail
<b>1</b>	Indication rail material: Makrolon max. 120 °C
<b>2</b>	Indication rail material: Aluminium max. 400 °C
<b>3</b>	Indication rail material: 1.4401 max. 400 °C
	<b>4. c to c distance &lt; 5000 mm</b>
<b>A</b>	< 5000 mm - without flange connection; DN 32 PN 40
<b>B</b>	> 5000 mm - with flange connection; DN 32 PN 40
	<b>5. Process connection side/side</b>
<b>Y</b>	Welding connection (please specify)
<b>Z</b>	Threaded connection (please specify)
<b>1</b>	Flanges DN 15 PN 40
<b>2</b>	Flanges DN 20 PN 40
<b>3</b>	Flanges DN 25 PN 40
<b>4</b>	Flanges DN 32 PN 40
<b>5</b>	Flanges DN 40 PN 40
<b>6</b>	Flanges DN 50 PN 40
<b>A</b>	Flanges 1/2" ANSI 300 lbs
<b>B</b>	Flanges 3/4" ANSI 300 lbs
<b>C</b>	Flanges 1" ANSI 300 lbs
<b>D</b>	Flanges 1 1/4" ANSI 300 lbs
<b>E</b>	Flanges 1 1/2" ANSI 300 lbs
<b>F</b>	Flanges 2" ANSI 300 lbs
	<b>5.1 Surface side flanges</b>
<b>0</b>	without
<b>A</b>	Standard- Surface Form C
<b>B</b>	Standard-Surface RF
<b>C</b>	Surface Form D Rz=40
<b>D</b>	Surface Form E Rz=16
<b>E</b>	Surface RFSF (smooth finished)
<b>F</b>	Surface Nut (DIN2512)
<b>G</b>	Surface groove large
<b>H</b>	Surface Feder (DIN2512)
<b>K</b>	Surface tongue-large
<b>L</b>	Surface RTJ (ANSI) 1/2" bis 2"
	<b>6. Side studs welded with T-pieces for 100 % X-ray testing</b>
<b>0</b>	without
<b>T</b>	T-pieces

**Order codes for magnetic level gauge type ITA-6 and ITA-6.0 (Continuation)**

Code	Description
<b>7. Float removal flange (bottom side)</b>	
1	End cap (only if float removal flange (top side))
2	Flange DN 32 PN 40 incl. blind flange
3	Flange DN 50 PN 40 incl. blind flange
A	Flange 2" ANSI 300 lbs incl. blind flange
4	Flange DN 50 PN 40 prepared for shut off valve on side
B	Flange 2" ANSI 300 lbs prepared for shut off valve on side
<b>7.1 Surface float removal flange (bottom side) (only DN50 or 2")</b>	
0	without (Float removal flange (bottom side) = end cap or < DN50 or 2")
A	Standard- Surface Form C
B	Standard-Surface RF
C	Surface Form D Rz=40
D	Surface Form E Rz=16
E	Surface RFSF (smooth finished)
F	Surface groove (DIN2512)
G	Surface groove large
H	Surface tongue (DIN2512)
K	Surface tongue-large
L	Surface RTJ (ANSI) 1/2" bis 2"
<b>7.2 Bolts &amp; Nuts float removal flange</b>	
0	without (Float removal flange (bottom side) = end cap)
1	M16 x 65 mm; mat. CS zined; flange DN 32 PN 40
2	M16 x 65 mm; mat. SS 1.4301; flange DN 32 PN 40
3	M16 x 65 mm; mat. CS zined; flange DN 50 PN 40
4	M16 x 65 mm; mat. SS 1.4301; flange DN 50 PN 40
A	5/8" x 83 mm; mat. CS zined A193B7; flange 2" ANSI 300 lbs
B	5/8" x 89 mm; mat. CS zined A193B7 / A1942H; flange 2" ANSI 300 lbs
C	5/8" x 83 mm; mat. SS A193B8 A1948M, flange 2" ANSI 300 lbs
D	5/8" x 89 mm; mat. SS A193B8 A1948M; flange 2" ANSI 300 lbs
E	Bolts & Nuts PTFE-coated (only DN50 or 2")
<b>8. Drain plug</b>	
0	without
1	Drain plug G 1/2" with soft iron gasket
2	Drain plug 1/2" NPT
3	Drain plug 3/4" NPT
4	Drain plug 1" NPT
<b>9. Additional drain flange, open</b>	
0	without
1	Drain stud with flange DN 15 PN 40
2	Drain stud with flange DN 20 PN 40
3	Drain stud with flange DN 25 PN 40
4	Drain stud with flange DN 32 PN 40
5	Drain stud with flange DN 40 PN 40
A	Drain stud with flange 1/2" ANSI 300 lbs
B	Drain stud with flange 3/4" ANSI 300 lbs
C	Drain stud with flange 1" ANSI 300 lbs
D	Drain stud with flange 1 1/4" ANSI 300 lbs
E	Drain stud with flange 1 1/2" ANSI 300 lbs

<b>Order codes for magnetic level gauge type ITA-6 and ITA-6.0 (Continuation)</b>
---

Code	Description
<b>9.1 Drain flange with concentric reducer (X-ray testing)</b>	
0	without
1	DN 15 PN 40
2	DN 20 PN 40
3	DN 25 PN 40
4	DN 32 PN 40
5	DN 40 PN 40
A	1/2" ANSI 300 lbs
B	3/4" ANSI 300 lbs
C	1" ANSI 300 lbs
D	1 1/4" ANSI 300 lbs
E	1 1/2" ANSI 300 lbs
<b>9.2 Surface open drain flange</b>	
0	without (Float removal flange (bottom side) = end cap or < DN50 or 2")
A	Standard- Surface Form C
B	Standard-Surface RF
C	Surface Form D Rz=40
D	Surface Form E Rz=16
E	Surface RFSF (smooth finished)
F	Surface groove (DIN2512)
G	Surface groove large
H	Surface tongue (DIN2512)
K	Surface tongue-large
L	Surface RTJ (ANSI) 1/2" bis 2"
<b>10. Float pipe top end finish</b>	
1	End cap
2	Flange with blind flange DN 32 PN 40
3	Flange with blind flange DN 50 PN 40
4	Flange with blind flange 2" ANSI 300 lbs
<b>10.1 Surface float pipe top end finish flange (only DN50 or 2")</b>	
0	without (Float pipe top end finish = End cap or < DN50 or 2")
A	Standard- Surface Form C
B	Standard-Surface RF
C	Surface Form D Rz=40
D	Surface Form E Rz=16
E	Surface RFSF (smooth finished)
F	Surface groove (DIN2512)
G	Surface groove large
H	Surface tongue (DIN2512)
K	Surface tongue-large
L	Surface RTJ (ANSI) 1/2" bis 2"

**Order codes for magnetic level gauge type ITA-6 and ITA-6.0 (Continuation)**

Code	Description
<b>10.2 Bolts &amp; nuts float pipe top end finish flange</b>	
0	without (Float pipe top end finish = End cap)
1	M16 x 65 mm; mat. CS zincd; flange DN 32 PN 40
2	M16 x 65 mm; mat. SS 1.4301; flange DN 32 PN 40
3	M16 x 65 mm; mat. CS zincd; flange DN 50 PN 40
4	M16 x 65 mm; mat. SS 1.4301; flange DN 50 PN 40
A	5/8" x 83 mm; mat. CS zincd A193B7; flange 2" ANSI 300 lbs
B	5/8" x 89 mm; mat. CS zincd A193B7 / A1942H; flange 2" ANSI 300 lbs
C	5/8" x 83 mm; mat. SS A193B8 A1948M, flange 2" ANSI 300 lbs
D	5/8" x 89 mm; mat. SS A193B8 A1948M; flange 2" ANSI 300 lbs
E	Bolts & Nuts PTFE-coated (only DN50 or 2")
<b>11. Vent plug at top end</b>	
0	without
1	Vent plug G 1/2" with soft iron gasket
2	Vent plug 1/2" NPT
3	Vent plug 3/4" NPT
4	Vent plug 1" NPT
<b>11.1 Vent flange welded to end cap instead of vent plug</b>	
0	without
1	Flanged DN 15 PN 40 (socket weld construction to endcap)
2	Flanged DN 20 PN 40 (socket weld construction to endcap)
3	Flanged DN 25 PN 40 (socket weld construction to endcap)
4	Flanged DN 32 PN 40 (socket weld construction to endcap)
5	Flanged DN 40 PN 40 (socket weld construction to endcap)
6	Flanged DN 50 PN 40 (socket weld construction to endcap)
A	Flanged 1/2" ANSI 300 lbs (socket weld construction to endcap)
B	Flanged 3/4" ANSI 300 lbs (socket weld construction to endcap)
C	Flanged 1" ANSI 300 lbs (socket weld construction to endcap)
D	Flanged 1 1/4" ANSI 300 lbs (socket weld construction to endcap)
E	Flanged 1 1/2" ANSI 300 lbs (socket weld construction to endcap)
F	Flanged 2" ANSI 300 lbs (socket weld construction to endcap)
<b>11.2 Vent flange with concentric reducer (X-ray testing)</b>	
0	without
1	DN 15 PN 40
2	DN 20 PN 40
3	DN 25 PN 40
4	DN 32 PN 40
5	DN 40 PN 40
A	1/2" ANSI 300 lbs
B	3/4" ANSI 300 lbs
C	1" ANSI 300 lbs
D	1 1/4" ANSI 300 lbs
E	1 1/2" ANSI 300 lbs

<b>Order codes for magnetic level gauge type ITA-6 and ITA-6.0 (Continuation)</b>
---

Code	Description
<b>11.3 Surface vent flange welded to end cap (only DN50 or 2")</b>	
0	without (Vent flange welded to end cap = without)
A	Standard- Surface Form C
B	Standard-Surface RF
C	Surface Form D Rz=40
D	Surface Form E Rz=16
E	Surface RFSF (smooth finished)
F	Surface groove (DIN2512)
G	Surface groove large
H	Surface tongue (DIN2512)
K	Surface tongue-large
L	Surface RTJ (ANSI) 1/2" bis 2"
<b>12. Counter flanges</b>	
0	without
1	DN 15 PN 40
2	DN 20 PN 40
3	DN 25 PN 40
4	DN 32 PN 40
5	DN 40 PN 40
6	DN 50 PN 40
A	1/2" 300 lbs
B	3/4" 300 lbs
C	1" 300 lbs
D	1 1/4" 300 lbs
E	1 1/2" 300 lbs
F	2" 300 lbs
<b>12.1 Surface counter flanges</b>	
0	without
A	Standard- Surface Form C
B	Standard-Surface RF
C	Surface Form D Rz=40
D	Surface Form E Rz=16
E	Surface RFSF (smooth finished)
F	Surface groove (DIN2512)
G	Surface groove large
H	Surface tongue (DIN2512)
K	Surface tongue-large
L	Surface RTJ (ANSI) 1/2" bis 2"
<b>12.2 Bolts &amp; Nuts counter flanges</b>	
0	without
1	M16 x 65 mm; mat. CS zincd; flange DN 32 PN 40
2	M16 x 65 mm; mat. SS 1.4301; flange DN 32 PN 40
3	M16 x 65 mm; mat. CS zincd; flange DN 50 PN 40
4	M16 x 65 mm; mat. SS 1.4301; flange DN 50 PN 40
A	5/8" x 83 mm; mat. CS zincd A193B7; flange 2" ANSI 300 lbs
B	5/8" x 89 mm; mat. CS zincd A193B7 / A1942H; flange 2" ANSI 300 lbs
C	5/8" x 83 mm; mat. SS A193B8 A1948M, flange 2" ANSI 300 lbs
D	5/8" x 89 mm; mat. SS A193B8 A1948M; flange 2" ANSI 300 lbs
E	Bolts & Nuts PTFE-coated (only DN50 or 2")

**Order codes for magnetic level gauge type ITA-6 and ITA-6.0 (Continuation)**

Code	Description
<b>13. Additional bracket welded to the float pipe</b>	
0	without
H	Bracket
<b>14. Float pipe seamless</b>	
0	without
S	60,3 x 2 mm seamless
<b>15. Float</b>	
F8F0SY	52 x 270 mm; material: 1.4404, pressure max. 30 bar; / sealed min. density of fluid: 0,7738 kg/dm <sup>3</sup>
F7D2SY	50,8 x 270 mm; material: Titanium, pressure max. 20 bar; / sealed min. density of fluid: 0,5723 kg/dm <sup>3</sup>
F8H0SY	52 x 270 mm; material: 1.4404, pressure max. 40 bar; / sealed min. density of fluid: 1,0 kg/dm <sup>3</sup>
F7H2SY	50,8 x 270 mm; material: Titanium, pressure max. 40 bar; / sealed min. density of fluid: 0,6391 kg/dm <sup>3</sup>
B7H2SY	50,8 x 150 mm; material: Titanium, pressure max. 40 bar; / sealed min. density of fluid: 1,1007 kg/dm <sup>3</sup>
G7H2SY	50,8 x 330 mm; material: Titanium, pressure max. 40 bar; / sealed min. density of fluid: 0,5694 kg/dm <sup>3</sup>
H7H2SY	50,8 x 430 mm; material: Titanium, pressure max. 40 bar; / sealed min. density of fluid: 0,53 kg/dm <sup>3</sup>
L7H2SY	50,8 x 630 mm; material: Titanium, pressure max. 40 bar; / sealed min. density of fluid: 0,4463 kg/dm <sup>3</sup>
K7H2SY	50,8 x 530 mm; material: Titanium, pressure max. 40 bar; / sealed min. density of fluid: 0,4370 kg/dm <sup>3</sup>
F8H3SY	52 x 270 mm; material: Titanium / E-CTFE (Halar®), pressure max. 40 bar; / sealed min. density of fluid: 0,7647 kg/dm <sup>3</sup>
F8E5SY	52 x 270 mm; material: Hastelloy C4, pressure max. 24 bar; / sealed min. density of fluid: 1,8 kg/dm <sup>3</sup>

1	2	3	4	5	6	7	8	9	10	11	12	13	14	15
ITA-6	L= mm													S Y

1	2	3	4	5	6	7	8	9	10	11	12	13	14	15
ITA-6.0	L= mm													S Y

### 3.11.1 ITA-6 Cryo (cryogenic applications)

Characteristics: PN40 / Float pipe and flange material 1.4404

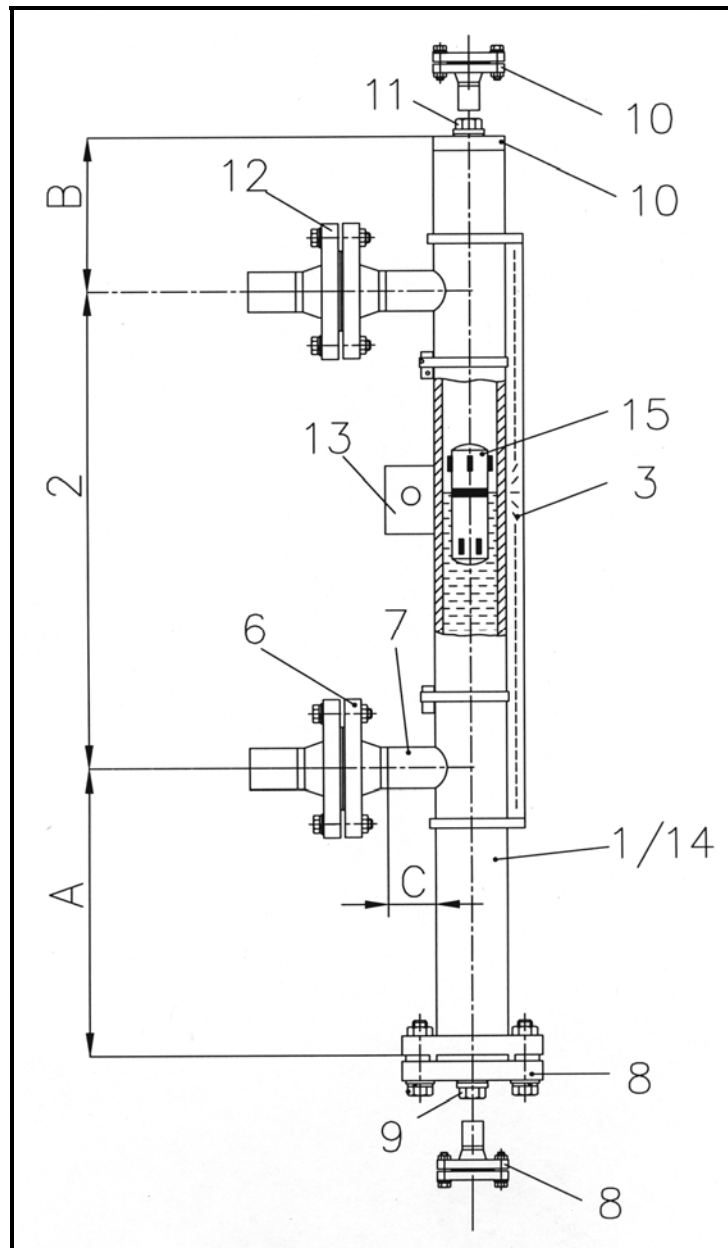

Parts drawing ITA-6 Cryo

**Key:**

- |   |  |    |                               |
|---|--|----|-------------------------------|
| 1 | Float pipe welded Dimensions 60,3 x 2 mm                   | 9  | Drain plug                    |
| 2 | c to c distance  | 10 | Additional drain flange, open |
| 3 | Design (indication rail)                                   | 11 | Float pipe top end finish     |
| 4 | Armaflex insulation  | 12 | Vent plug                     |
| 6 | Process connection side/side                               | 13 | Counter flanges               |
| 7 | Side studs welded with T-pieces for 100 %<br>X-ray testing | 14 | Additional bracket            |
| 8 | Float removal flange                                       | 15 | Float pipe seamless           |
|   |  | 16 | Float                         |

**Technical specification magnetic level gauge type ITA-6 CRYO**

Principle	:	Communicating tubes with magnetic float
Mounting position	:	vertical
Measuring range	:	<b>max. 5000 mm (one-part)</b> > 5000 mm 2- or multipart
Pipe diameter	:	<b>60,3 x 2 mm welded,</b>
Process connection	:	to specify: <b>Flanges DN15-50 (1/2"-2"300#)</b>
Drain/vent connections	:	<b>Plug G1/2"</b> (for more please see price list)
Pipe material	:	<b>1.4404</b> , 1.4435, 1.4539, Hastelloy C4 (2.4610), Inconel 625 (2.4856), Inconel 825 (2.4858), Titan (3.7035) Other materials also possible (on request)
Flange material	:	same as pipe material
Float material	:	<b>1.4404</b> Titan, Titan/E-CTFE-coated
Operation temperature	:	--200...+100 °C
Operation pressure	:	max. 40 bar
Operation density	:	min. 0,4693 kg/dm <sup>3</sup>
Bolts & Nuts	:	<b>CS</b> (min. -10 °C) SS or material in acc. with DIN 17280
Gasket	:	<b>PTFE up to 100 °C</b> <b>Klingsil C4400 up to 175 °C</b> <b>Graphit spiral wound up to 400 °C**</b>
Indication rail	:	<b>PTFE min. -150 °C</b> <b>Klingsil TOP Chem 2000</b>
Float types	:	Cylindrical, sealed type Dimensions: - <b>Ø50,8 x 270 mm</b>
Standard dimensions	:	- A = 240* - B = 130 - C = 40

**Base equipment printed in bold letters!**

**Not for vaporizing media (e.g. Ammonia)**



### 3.11.2 ITA-6.0 Cryo (cryogenic applications)

Characteristics: PN40 / Float pipe: 1.4404 Flange: CS

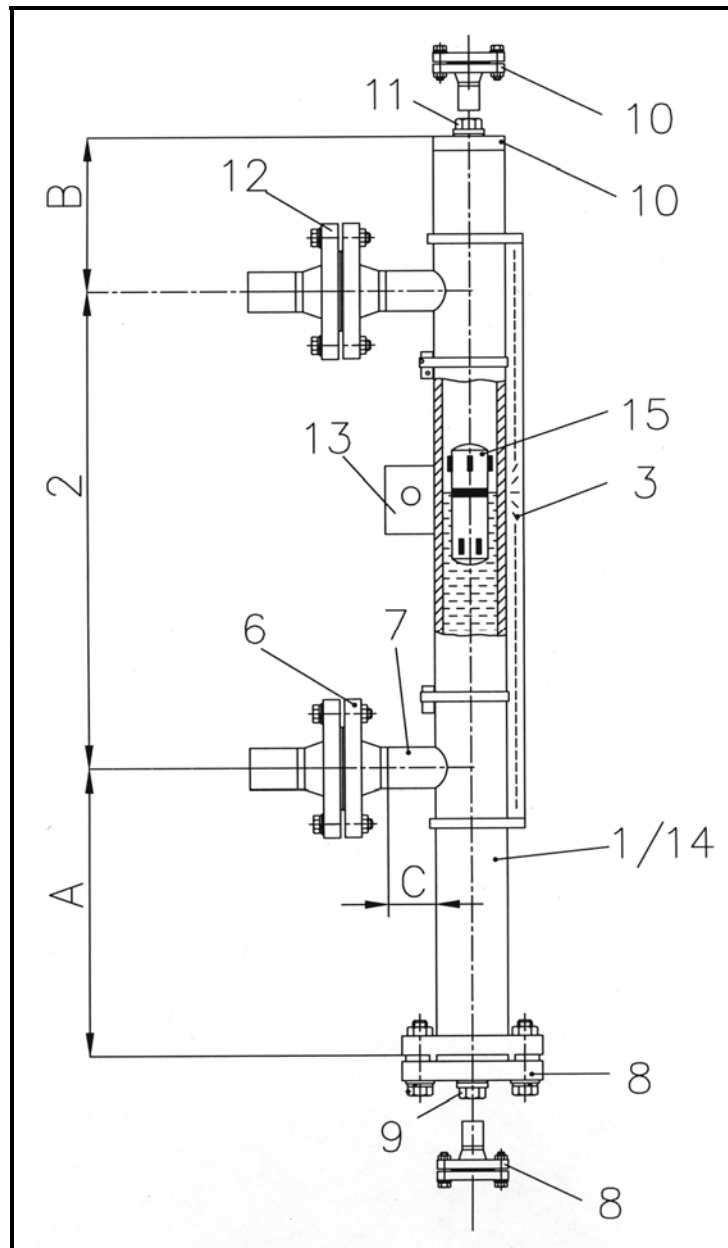

Parts drawing ITA-6.0 Cryo

**Key:**

- |   |   |    |                               |
|---|---|----|-------------------------------|
| 1 | Float pipe welded Dimensions 60,3 x 2 mm                | 9  | Drain plug                    |
| 2 | c to c distance   | 10 | Additional drain flange, open |
| 3 | Design (indication rail)                                | 11 | Float pipe top end finish     |
| 4 | Armaflex insulation                                     | 12 | Vent plug                     |
| 6 | Process connection side/side                            | 13 | Counter flanges               |
| 7 | Side studs welded with T-pieces for 100 % X-ray testing | 14 | Additional bracket            |
| 8 | Float removal flange                                    | 15 | Float pipe seamless           |
|   |   | 16 | Float                         |

**Technical specification magnetic level gauge type ITA-6.0 CRYO**

Principle	:	Communicating tubes with magnetic float
Mounting position	:	vertical
Measuring range	:	<b>max. 5000 mm (one-part)</b> > 5000 mm 2- or multipart
Pipe diameter	:	<b>60,3 x 2 mm welded,</b>
Process connection	:	to specify: <b>Flanges DN15-50 (1/2"-2"300#)</b>
Drain/vent connections	:	<b>Plug G1/2"</b> (for more please see price list)
Pipe material	:	<b>1.4404</b> , 1.4435, 1.4539, Hastelloy C4 (2.4610), Inconel 625 (2.4856), Inconel 825 (2.4858), Titan (3.7035) Other materials also possible (on request)
Flange material	:	CS
Float material	:	<b>1.4404</b> Titan, Titan/E-CTFE-coated
Operation temperature	:	-200...+100 °C
Operation pressure	:	max. 40 bar
Operation density	:	min. 0,4693 kg/dm <sup>3</sup>
Bolts & Nuts	:	<b>CS</b> (min. -10 °C) SS or material in acc. with DIN 17280
Gasket	:	<b>PTFE up to 100 °C</b> <b>Klingsil C4400 up to 175 °C</b> <b>Graphit spiral wound up to 400 °C**</b>
Indication rail	:	<b>PTFE min. -150 °C</b> <b>Klingsil TOP Chem 2000</b>
Float types	:	Cylindrical, sealed type Dimensions: - <b>Ø50,8 x 270 mm</b>
Standard dimensions	:	- A = 240* - B = 130 - C = 40

**Base equipment printed in bold letters!**

**Not for vaporizing media (e.g. Ammonia)**

<b>Order codes for magnetic level gauge type ITA-6 Cryo and ITA-6.0 Cryo</b>
--

Code	Description:
<b>ITA-6-Cryo ITA-6.0-Cryo</b>	<b>1. Float pipe welded Dimensions 60,3 x 2 mm</b>
	<b>2. c to c distance</b>
<b>L</b>	c to c distance in mm
	<b>3. Design</b>
<b>0</b>	without indication rail
<b>1</b>	Indication rail material: Aluminium max. 400 °C
<b>2</b>	Indication rail material: 1.4401 max. 400 °C
	<b>4. Armaflex-Insulation</b>
<b>0</b>	without Armaflex insulation
<b>F</b>	Thickness: 12 mm, bis -15 °C
<b>R</b>	Thickness: 30 mm, bis -50 °C
<b>T</b>	Thickness: 70 mm, bis -200 °C incl. Makrolon window
	<b>5. C to C distance &lt; 5000 mm</b>
<b>A</b>	< 5000 mm - without flange connection; DN 32 PN 40
<b>B</b>	> 5000 mm - with flange connection; DN 32 PN 40
	<b>6. Process connection side/side</b>
<b>Y</b>	Welding connection (please specify)
<b>Z</b>	Threaded connection (please specify)
<b>1</b>	Flanges DN 15 PN 40
<b>2</b>	Flanges DN 20 PN 40
<b>3</b>	Flanges DN 25 PN 40
<b>4</b>	Flanges DN 32 PN 40
<b>5</b>	Flanges DN 40 PN 40
<b>6</b>	Flanges DN 50 PN 40
<b>A</b>	Flanges 1/2" ANSI 300 lbs
<b>B</b>	Flanges 3/4" ANSI 300 lbs
<b>C</b>	Flanges 1" ANSI 300 lbs
<b>D</b>	Flanges 1 1/4" ANSI 300 lbs
<b>E</b>	Flanges 1 1/2" ANSI 300 lbs
<b>F</b>	Flanges 2" ANSI 300 lbs
	<b>6.1 Surface side flanges</b>
<b>0</b>	without
<b>F</b>	Groove (DIN2512)
<b>H</b>	Tongue (DIN2512)
	<b>7. Side studs welded with T-pieces for 100 % X-ray testing</b>
<b>0</b>	without
<b>T</b>	T-pieces
	<b>8. Float removal flange (bottom side)</b>
<b>1</b>	End cap (only if float removal flange (top side))
<b>2</b>	Flange DN 50 PN 40 incl. blind flange
<b>A</b>	Flange 2" ANSI 300 lbs incl. blind flange

**Order codes for magnetic level gauge type ITA-6 Cryo and ITA-6.0 Cryo (Cont.)**

Code	Description:
<b>8.1 Surface float removal flange (bottom side) (only DN50 or 2")</b>	
0	without (Float removal flange (bottom side) = end cap or < DN50 or 2")
F	Groove (DIN2512)
H	Tongue (DIN2512)
<b>8.2 Bolts &amp; Nuts float removal flange</b>	
0	without (Float removal flange (bottom side) = end cap)
1	M16 x 65 mm; mat. CS zincd; Flange DN 50 PN 40
2	M16 x 65 mm; mat. SS 1.4301; Flange DN 50 PN 40
A	5/8" x 89 mm; mat. CS zincd A193B7 / A1942H ; Flange 2" ANSI 300 lbs
B	5/8" x 89 mm; mat. SS A193B8 A1948M; Flange 2" ANSI 300 lbs
C	Bolts & Nuts PTFE-coated
<b>9. Drain plug</b>	
0	without
1	G 1/2" DIN1910
<b>10. Float pipe top end finish</b>	
1	End cap
2	Flange with blind flange DN 50 PN 40
A	Flange with blind flange 2" ANSI 300 lbs
<b>10.1 Surface float pipe top end finish flange (only DN50 or 2")</b>	
0	without (Float pipe top end finish = End cap or < DN50 or 2")
F	Groove (DIN2512)
H	Tongue (DIN2512)
<b>10.2 Bolts &amp; nuts float pipe top end finish flange</b>	
0	without (Float pipe top end finish = End cap)
1	M16 x 65 mm; mat. CS zincd; Flange DN 50 PN 40
2	M16 x 65 mm; mat. SS 1.4301; Flange DN 50 PN 40
A	5/8" x 89 mm; mat. CS zincd A193B7 / A1942H ; Flange 2" ANSI 300 lbs
B	5/8" x 89 mm; mat. SS A193B8 A1948M; Flange 2" ANSI 300 lbs
C	Bolts & Nuts PTFE-coated
<b>11. Vent plug on topside</b>	
0	without
1	Vent plug G 1/2" with soft iron gasket

**Order codes for magnetic level gauge type ITA-6 Cryo and ITA-6.0 Cryo (Cont.)**

Code	Description:
<b>12. Counter flanges</b>	
0	without
1	DN 15 PN 40
2	DN 20 PN 40
3	DN 25 PN 40
4	DN 32 PN 40
5	DN 40 PN 40
6	DN 50 PN 40
A	1/2" 300 lbs
B	3/4" 300 lbs
C	1" 300 lbs
D	1 1/4" 300 lbs
F	1 1/2" 300 lbs
G	2" 300 lbs
<b>12.1 Surface counter flanges</b>	
0	without
F	Groove (DIN2512)
H	Tongue (DIN2512)
<b>12.2 Bolts &amp; Nuts counter flanges</b>	
0	without
1	M16 x 65 mm; mat. CS zined; Flange DN 50 PN 40
2	M16 x 65 mm; mat. SS 1.4301; Flange DN 50 PN 40
A	5/8" x 89 mm; mat. CS zined A193B7 / A1942H ; Flange 2" ANSI 300 lbs
B	5/8" x 89 mm; mat. SS A193B8 A1948M; Flange 2" ANSI 300 lbs
C	Bolts & Nuts PTFE-coated
<b>13. Additional bracket welded to the float pipe</b>	
0	without
H	Bracket
<b>14. Float pipe seamless</b>	
0	without
S	60,3 x 2 mm seamless
<b>15. Float</b>	
F702SY	50,8 x 270; material: Titanium; pressure max. 40 bar; min. density of liquid: 0,6931 kg/dm <sup>3</sup> sealed
K702SY	50,8 x 530; material: Titanium; pressure max. 40 bar; min. density of liquid: 0,4693 kg/dm <sup>3</sup> sealed

1	2	3	4	5	6	7	8	9	10	11	12	13	14	15					
ITA-6-Cryo	L= mm														7	0	2	S	Y

1	2	3	4	5	6	7	8	9	10	11	12	13	14	15					
ITA-6.0-Cryo	L= mm														7	0	2	S	Y

**3.12.1 ITA-6 CR64 (cryogenic applications)**

Characteristics: PN40 / Float pipe and flange material 1.4404

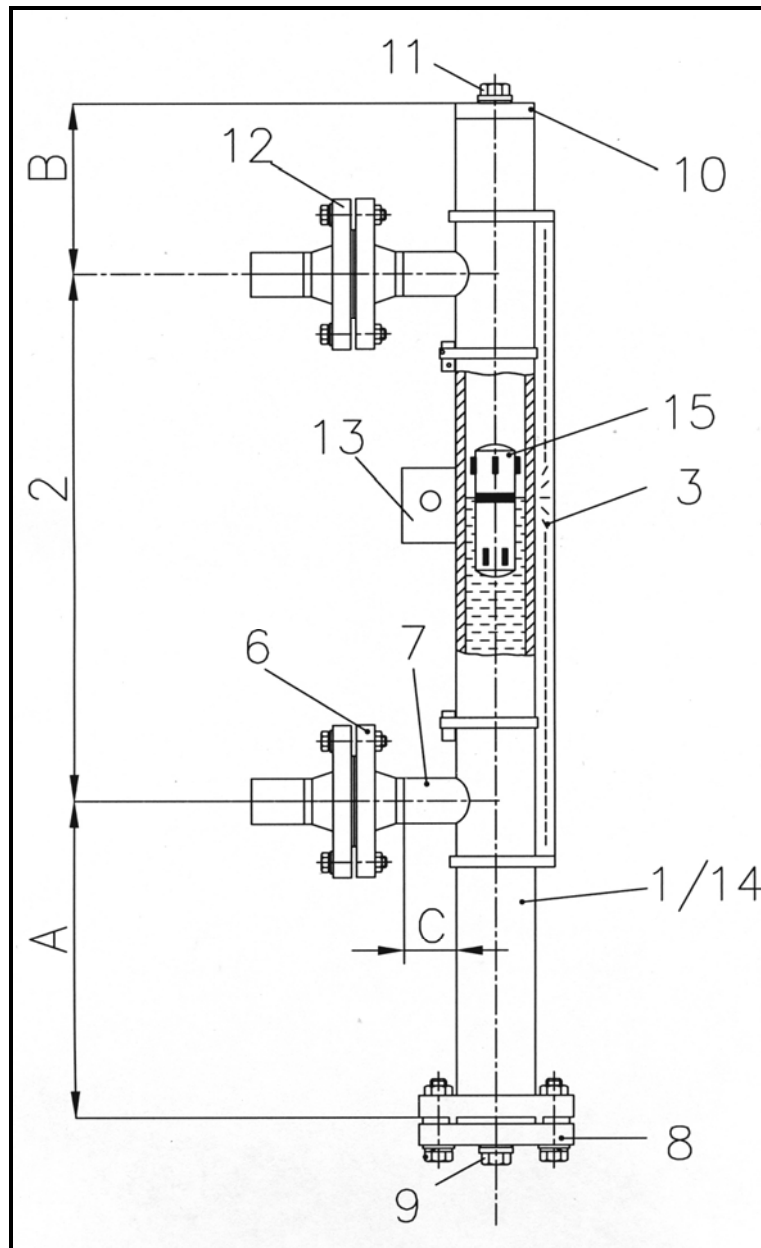

Parts drawing ITA-6 CR64

**Key:**

- |   |   |    |                               |
|---|---|----|-------------------------------|
| 1 | Float pipe welded Dimensions 64 x 2 mm                  | 9  | Drain plug                    |
| 2 | c to c distance   | 10 | Additional drain flange, open |
| 3 | Design (indication rail)                                | 11 | Float pipe top end finish     |
| 4 | Armaflex insulation                                     | 12 | Vent plug                     |
| 6 | Process connection side/side                            | 13 | Counter flanges               |
| 7 | Side studs welded with T-pieces for 100 % X-ray testing | 14 | Additional bracket            |
| 8 | Float removal flange                                    | 15 | Float pipe seamless           |
|   |   | 16 | Float                         |

### Technical specification magnetic level gauge type ITA-6 CR64

Principle	:	Communicating tubes with magnetic float
Mounting position	:	vertical
Measuring range	:	<b>max. 5000 mm (one-part)</b> > 5000 mm 2- or multipart
Pipe diameter	:	<b>64 x 2 mm welded,</b>
Process connection	:	to specify: <b>Flanges DN15-50 (1/2"-2"300#)</b>
Drain/vent connections	:	<b>Plug G1/2"</b> (for more please see price list)
Pipe material	:	<b>1.4404</b>
Flange material	:	same as pipe material
Float material	:	<b>1.4404</b> Titan, Titan/E-CTFE-coated
Operation temperature	:	-200...+100 °C
Operation pressure	:	max. 40 bar
Operation density	:	min. 0,4693 kg/dm <sup>3</sup>
Bolts & Nuts	:	<b>CS</b> (min. -10 °C) SS or material in acc. with DIN 17280
Gasket	:	<b>PTFE up to 100 °C</b> <b>Klingsil C4400 up to 175 °C</b> <b>Graphit spiral wound up to 400 °C**</b>
Indication rail	:	<b>PTFE min. -150 °C</b> <b>Klingsil TOP Chem 2000</b>
Float types	:	Cylindrical, sealed type Dimensions: - <b>Ø50,8 x 270 mm</b> - <b>Ø50,8 x 530 mm</b>
Standard dimensions	:	- A = 240* - B = 130 - C = 40

**Base equipment printed in bold letters!**

**Not for vaporizing media (e.g. Ammonia)**

**3.12.2 ITA-6.0 CR64 (cryogenic applications)**

Characteristics: PN40 / Float pipe: 1.4404 Flanges:CS

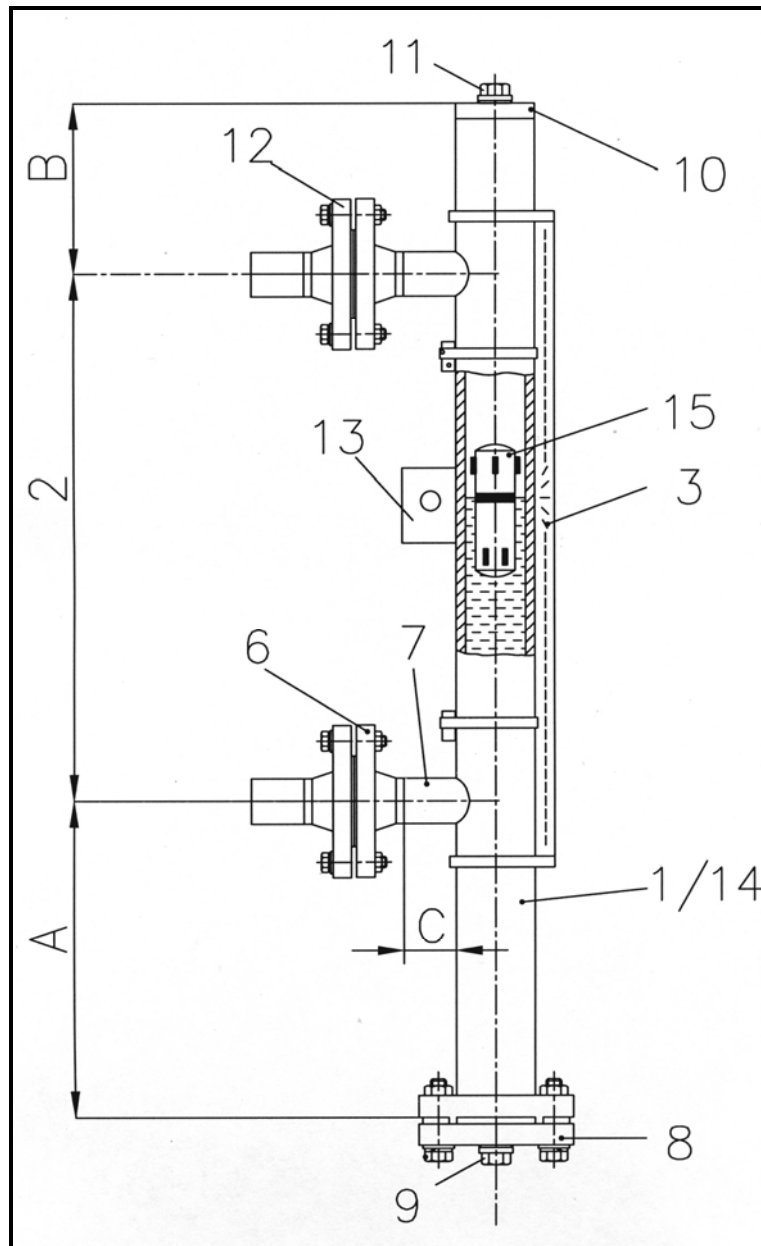

Parts drawing ITA-6.0 CR64

**Key:**

- |   |   |    |                               |
|---|---|----|-------------------------------|
| 1 | Float pipe welded Dimensions 64 x 2 mm                  | 9  | Drain plug                    |
| 2 | c to c distance   | 10 | Additional drain flange, open |
| 3 | Design (indication rail)                                | 11 | Float pipe top end finish     |
| 4 | Armaflex insulation                                     | 12 | Vent plug                     |
| 6 | Process connection side/side                            | 13 | Counter flanges               |
| 7 | Side studs welded with T-pieces for 100 % X-ray testing | 14 | Additional bracket            |
| 8 | Float removal flange                                    | 15 | Float pipe seamless           |
|   |   | 16 | Float                         |



### Technical specification magnetic level gauge type ITA-6.0 CR64

Principle	:	Communicating tubes with magnetic float
Mounting position	:	vertical
Measuring range	:	<b>max. 5000 mm (one-part)</b> > 5000 mm 2- or multipart
Pipe diameter	:	<b>64 x 2 mm welded,</b>
Process connection	:	to specify: <b>Flanges DN15-50 (1/2"-2"300#)</b>
Drain/vent connections	:	<b>Plug G1/2"</b> (for more please see price list)
Pipe material	:	<b>1.4404</b>
Flange material	:	CS
Float material	:	<b>1.4404</b> Titan, Titan/E-CTFE-coated
Operation temperature	:	-200...+100 °C
Operation pressure	:	max. 40 bar
Operation density	:	min. 0,4693 kg/dm <sup>3</sup>
Bolts & Nuts	:	<b>CS</b> (min. -10 °C) SS or material in acc. with DIN 17280
Gasket	:	<b>PTFE up to 100 °C</b> <b>Klingsil C4400 up to 175 °C</b> <b>Graphit spiral wound up to 400 °C**</b>
Indication rail	:	<b>PTFE min. -150 °C</b> <b>Klingsil TOP Chem 2000</b>
Float types	:	Cylindrical, sealed type Dimensions: - <b>Ø50,8 x 270 mm</b> - <b>Ø50,8 x 530 mm</b>
Standard dimensions	:	- A = 240* - B = 130 - C = 40

**Base equipment printed in bold letters!**

**Not for vaporizing media (e.g. Ammonia)**

**Order codes for magnetic level gauge type ITA-6 CR64 and ITA-6.0 CR64**

Code	Description
ITA-6-CR64 ITA-6.0 CR64	<b>1. Float pipe welded</b> Dimensions 64 x 2 mm
	<b>2. c to c distance</b>
L	c to c distance in mm
	<b>3. Design</b>
0	without indication rail
1	Indication rail material: Aluminium max. 400 °C
2	Indication rail material: 1.4401 max. 400 °C
	<b>4. Armaflex-Insulation</b>
0	without Armaflex insulation
F	Thickness: 12 mm, bis -15 °C
R	Thickness: 30 mm, bis -50 °C
T	Thickness: 70 mm, bis -200 °C incl. Makrolon window
	<b>5. C to C distance &lt; 5000 mm</b>
A	< 5000 mm - without flange connection; DN 32 PN 40
B	> 5000 mm - with flange connection; DN 32 PN 40
	<b>6. Process connection side/side</b>
Y	Welding connection (please specify)
Z	Threaded connection (please specify)
1	Flanges DN 15 PN 40
2	Flanges DN 20 PN 40
3	Flanges DN 25 PN 40
4	Flanges DN 32 PN 40
5	Flanges DN 40 PN 40
6	Flanges DN 50 PN 40
A	Flanges 1/2" ANSI 300 lbs
B	Flanges 3/4" ANSI 300 lbs
C	Flanges 1" ANSI 300 lbs
D	Flanges 1 1/4" ANSI 300 lbs
E	Flanges 1 1/2" ANSI 300 lbs
F	Flanges 2" ANSI 300 lbs
	<b>6.1 Surface side flanges</b>
0	without
F	Groove (DIN2512)
H	Tongue (DIN2512)
	<b>7. Side studs welded with T-pieces for 100 % X-ray testing</b>
0	without
T	T-pieces
	<b>8. Float removal flange (bottom side)</b>
1	End cap (only if float removal flange (top side))
2	Flange DN 50 PN 40 incl. blind flange
A	Flange 2" ANSI 300 lbs incl. blind flange

**Order codes for magnetic level gauge type ITA-6 CR64 and ITA-6.0 CR64 (Cont.)**

Code	Description
	<b>8.1 Surface float removal flange (bottom side) (only DN50 or 2")</b>
0	without (Float removal flange (bottom side) = end cap or < DN50 or 2")
F	Groove (DIN2512)
H	Tongue (DIN2512)
	<b>8.2 Bolts &amp; Nuts float removal flange</b>
0	without (Float removal flange (bottom side) = end cap)
1	M16 x 65 mm; mat. CS zincd; Flange DN 50 PN 40
2	M16 x 65 mm; mat. SS 1.4301; Flange DN 50 PN 40
A	5/8" x 89 mm; mat. CS zincd A193B7 / A1942H ; Flange 2" ANSI 300 lbs
B	5/8" x 89 mm; mat. SS A193B8 A1948M; Flange 2" ANSI 300 lbs
C	Bolts & Nuts PTFE-coated
	<b>9. Drain plug</b>
0	without
1	G 1/2" DIN1910
	<b>10. Float pipe top end finish</b>
1	End cap
2	Flange with blind flange DN 50 PN 40
A	Flange with blind flange 2" ANSI 300 lbs
	<b>10.1 Surface float pipe top end finish flange (only DN50 or 2")</b>
0	without (Float pipe top end finish = End cap or < DN50 or 2")
F	Groove (DIN2512)
H	Tongue (DIN2512)
	<b>10.2 Bolts &amp; nuts float pipe top end finish flange</b>
0	without (Float pipe top end finish = End cap)
1	M16 x 65 mm; mat. CS zincd; Flange DN 50 PN 40
2	M16 x 65 mm; mat. SS 1.4301; Flange DN 50 PN 40
A	5/8" x 89 mm; mat. CS zincd A193B7 / A1942H ; Flange 2" ANSI 300 lbs
B	5/8" x 89 mm; mat. SS A193B8 A1948M; Flange 2" ANSI 300 lbs
C	Bolts & Nuts PTFE-coated
	<b>11. Vent plug on topside</b>
0	without
1	Vent plug G 1/2" with soft iron gasket

**Order codes for magnetic level gauge type ITA-6 CR64 and ITA-6.0 CR64 (Cont.)**

Code	Description
<b>12. Counter flanges</b>	
0	without
1	DN 15 PN 40
2	DN 20 PN 40
3	DN 25 PN 40
4	DN 32 PN 40
5	DN 40 PN 40
6	DN 50 PN 40
A	1/2" 300 lbs
B	3/4" 300 lbs
C	1" 300 lbs
D	1 1/4" 300 lbs
E	1 1/2" 300 lbs
F	2" 300 lbs
<b>12.1 Surface counter flanges</b>	
0	without
F	Groove (DIN2512)
H	Tongue (DIN2512)
<b>12.2 Bolts &amp; Nuts counter flanges</b>	
0	without
1	M16 x 65 mm; mat. CS zincd; Flange DN 32 PN 40
2	M16 x 65 mm; mat. SS 1.4301; Flange DN 32 PN 40
3	M16 x 65 mm; mat. CS zincd; Flange DN 50 PN 40
4	M16 x 65 mm; mat. SS 1.4301; Flange DN 50 PN 40
A	5/8" x 89 mm; mat. CS zincd A193B7 / A1942H ; Flange 2" ANSI 300 lbs
B	5/8" x 89 mm; mat. SS A193B8 A1948M; Flange 2" ANSI 300 lbs
C	Bolts & Nuts PTFE-coated
<b>13. Additional bracket welded to the float pipe</b>	
0	without
H	Bracket
<b>14. Float pipe seamless</b>	
0	without
S	60,3 x 2 mm seamless; each 100 mm
<b>15. Float</b>	
<b>F702SY</b>	50,8 x 270;material: Titanium; pressure max. 40 bar; min. density of liquid: 0,6931 kg/dm <sup>3</sup> sealed
<b>K702SY</b>	50,8 x 530; material: Titanium; pressure max. 40 bar; min. density of liquid: 0,4693 kg/dm <sup>3</sup> sealed

1	2	3	4	5	6	7	8	9	10	11	12	13	14	15				
ITA-6-CR64	L= mm													7	0	2	S	Y

1	2	3	4	5	6	7	8	9	10	11	12	13	14	15				
ITA-6.0-CR64	L= mm													7	0	2	S	Y

### 3.13 ITA-6.8 (wetted parts E-TFE-coated, for vacuum service)

Characteristics: PN40 / Float pipe and flange material 1.4404

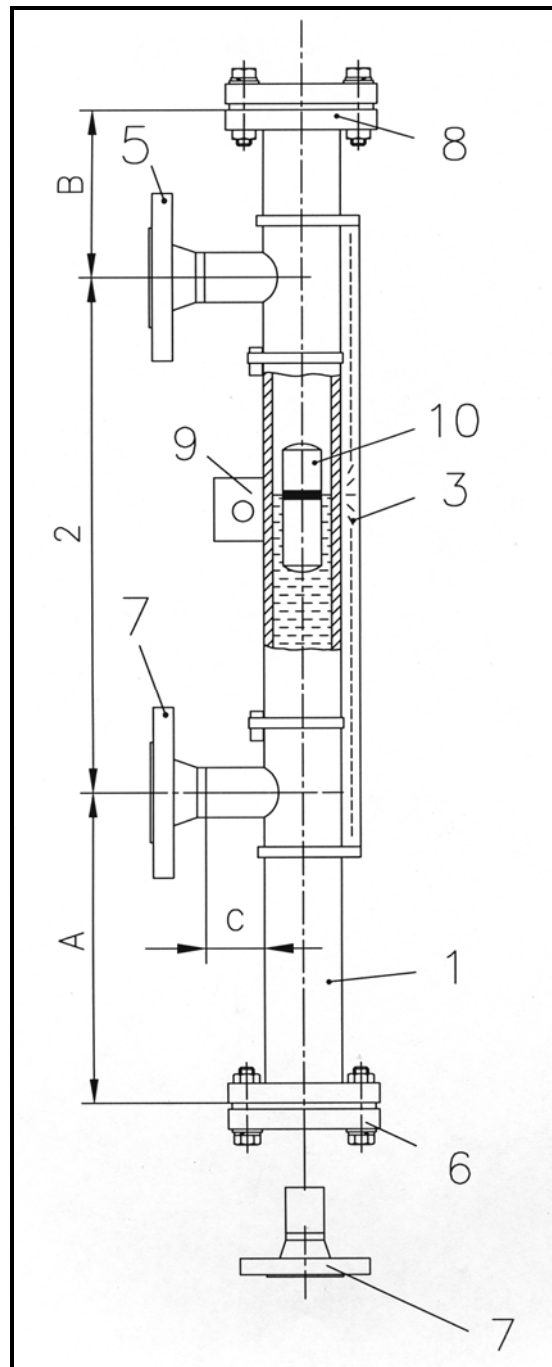

Parts drawing ITA-6.8

**Key:**

- |   |  |    |                               |
|---|--|----|-------------------------------|
| 1 | Float pipe welded Dimensions 60,3 x 2 mm | 7  | Additional drain flange, open |
| 2 | c to c distance                          | 8  | Float pipe top end finish     |
| 3 | Design (indication rail)                 | 9  | Additional bracket            |
| 5 | Process connection side/side             | 10 | Float pipe seamless           |
| 6 | Float removal flange                     | 11 | Vent plug                     |
| 7 | Additional drain flange, open            |    |                               |
| 8 | Float pipe top end finish                |    |                               |

### Technical specification magnetic level gauge type ITA-6.8

Principle	:	Communicating tubes with magnetic float
Mounting position	:	vertical
Measuring range	:	<b>max. 2800 mm (one-part/total length max. 2900 mm)</b> > 2900 mm 2- or multipart
Pipe diameter	:	<b>69 x 2 mm welded,</b> 69 x 2 seamless <b>butt weld construction with necking connections</b>
Process connection	:	to specify: <b>Flanges DN20-50 (3/4"-2"150# RF)</b>
Drain/vent connections	:	<b>see price list</b>
Pipe material	:	<b>1.4404, wetted parts E-CTFE-coated</b>
Flange material	:	as pipe material
Float material	:	<b>Titanium/E-TFE-coated</b>
Operation temperature	:	-50...+160 °C
Operation pressure	:	max. 40 bar / <b>vacuum resistant</b>
Operation density	:	min. 0,7647 kg/dm <sup>3</sup>
Bolts & Nuts	:	<b>CS</b> SS
Gasket	:	<b>PTFE up to 100 °C</b> <b>Klingersil-chem-200 up to 260 °C</b>
Indication rail	:	<b>Makrolon up to 120 °C</b> Aluminium up to 400 °C 1.4301 up to 400 °C
Float types	:	Cylindrical, sealed type Length: - <b>270 mm</b> - 150 mm - 330 mm - 430 mm - 530 mm
Dimensions	:	- A= 240* - B= 130 - C= 40

**Base equipment printed in bold letters!**

<b>Order codes for magnetic level gauge type ITA-6.8</b>
--

Code	Description
<b>ITA-6.8</b>	<b>1. Float pipe welded Dimensions 69 x 2 mm</b>
	<b>2. C to C distance</b>
<b>L</b>	c to c distance in mm
	<b>3. Design</b>
<b>0</b>	without indication rail
<b>1</b>	Indication rail material: Makrolon, max. 120 °C
<b>2</b>	Indication rail material: Aluminium max. 400 °C
<b>3</b>	Indication rail material: 1.4401 max. 400 °C
	<b>4. C to C distance &lt; 2800 mm / total length 2900 mm</b>
<b>A</b>	< 2800 mm - without flange connection; DN 50 PN 40
<b>B</b>	> 2800 mm - with flange connection; DN 50 PN 40
	<b>5. Process connection side/side</b>
<b>1</b>	Flanges DN 20 PN 40
<b>2</b>	Flanges DN 25 PN 40
<b>3</b>	Flanges DN 32 PN 40
<b>4</b>	Flanges DN 40 PN 40
<b>5</b>	Flanges DN 50 PN 40
<b>A</b>	Flanges 3/4" ANSI 300 lbs
<b>B</b>	Flanges 1" ANSI 300 lbs
<b>C</b>	Flanges 1 1/4" ANSI 300 lbs
<b>D</b>	Flanges 1 1/2" ANSI 300 lbs
<b>E</b>	Flanges 2" ANSI 300 lbs
	<b>6. Float removal flange (bottom side)</b>
<b>1</b>	Flange DN 50 PN 40 incl. blind flange
<b>A</b>	Flange 2" ANSI 300 lbs incl. blind flange
	<b>6.1 Bolts &amp; Nuts float removal flange</b>
<b>1</b>	M16 x 65 mm; mat. CS zincd; Flange DN 50 PN 40
<b>2</b>	M16 x 65 mm; mat. SS 1.4301; Flange DN 50 PN 40
<b>A</b>	5/8" x 89 mm; mat. CS zincd A193B7 / A1942H ; Flange 2" ANSI 300 lbs
<b>B</b>	5/8" x 89 mm; mat. SS A193B8 A1948M; Flange 2" ANSI 300 lbs
<b>C</b>	Bolts & Nuts PTFE-coated
	<b>7. Drain flange</b>
<b>1</b>	DN 25 PN 40 (socket weld construction to blind flange)
<b>2</b>	DN 32 PN 40 (socket weld construction to blind flange)
<b>3</b>	DN 40 PN 40 (socket weld construction to blind flange)
<b>A</b>	3/4" ANSI 300 lbs (socket weld construction to blind flange)
<b>B</b>	1" ANSI 300 lbs (socket weld construction to blind flange)
<b>C</b>	1 1/4" ANSI 300 lbs (socket weld construction to blind flange)
<b>D</b>	1 1/2" 300 lbs (socket weld construction to blind flange)
	<b>7. 1 Nuts &amp; Bolts drain flange</b>
<b>1</b>	M16 x 65 mm; mat. CS zincd; Flange DN 50 PN 40
<b>2</b>	M16 x 65 mm; mat. SS 1.4301; Flange DN 50 PN 40
<b>A</b>	5/8" x 89 mm; mat. CS zincd A193B7 / A1942H ; Flange 2" ANSI 300 lbs
<b>B</b>	5/8" x 89 mm; mat. SS A193B8 A1948M; Flange 2" ANSI 300 lbs
<b>C</b>	Bolts & Nuts PTFE-coated

**Order codes for magnetic level gauge type ITA-6.8 (Continuation)**

Code	Description
<b>8. Vent flange</b>	
1	DN 25 PN 40 (socket weld construction to blind flange)
2	DN 32 PN 40 (socket weld construction to blind flange)
3	DN 40 PN 40 (socket weld construction to blind flange)
A	3/4" ANSI 300 lbs (socket weld construction to blind flange)
B	1" ANSI 300 lbs (socket weld construction to blind flange)
C	1 1/4" ANSI 300 lbs (socket weld construction to blind flange)
D	1 1/2" 300 lbs (socket weld construction to blind flange)
<b>8.1 Nuts &amp; Bolts vent flange</b>	
3	M16 x 65 mm; mat. CS zincd; Flange DN 50 PN 40
4	M16 x 65 mm; mat. SS 1.4301; Flange DN 50 PN 40
6	5/8" x 89 mm; mat. CS zincd A193B7 / A1942H ; Flange 2" ANSI 300 lbs
8	5/8" x 89 mm; mat. SS A193B8 A1948M; Flange 2" ANSI 300 lbs
9	Bolts & Nuts PTFE-coated
<b>9. Additional bracket welded to the float pipe</b>	
0	without
A	Bracket
<b>10. Float</b>	
E808VY	50x255; material: PVDF; pressure max. 10 bar; min. density of liquid: 0,85 kg/dm <sup>3</sup>
B804VY	52 x 180 material: Titanium/E-CTFE-coated ; pressure max. 40 bar; min. density of liquid:0,902 kg/dm <sup>3</sup>
E804VY	52x270; material: T Titanium/E-CTFE-coated ; pressure max. 40 bar; min. density of liquid: 0,7647 kg/dm <sup>3</sup>

1	2	3	4	5	6	7	7	8	9	10				
ITA-6.8	L=	mm									8	0	V	Y



### 3.14.1 ITA-7

Characteristics: **PN64 / Float pipe and flange material 1.4404**

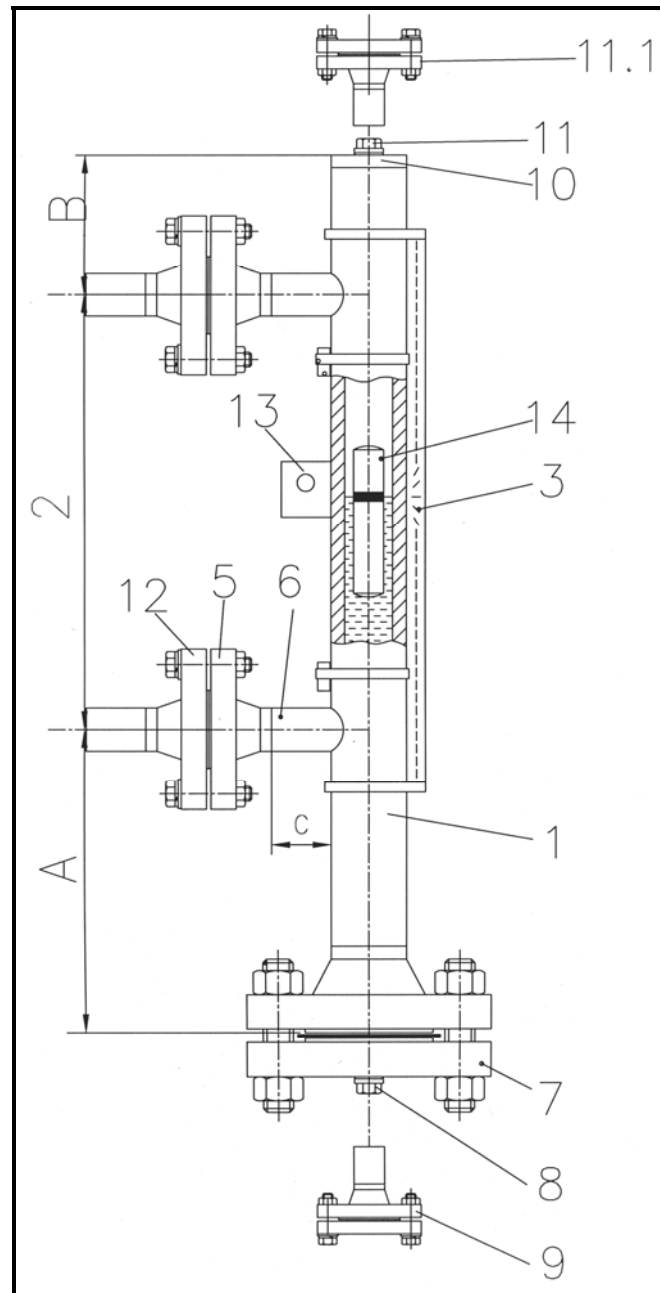

Parts drawing ITA-7

**Key:**

- |   |   |    |                               |
|---|---|----|-------------------------------|
| 1 | Float pipe welded Dimensions 60,3 x 2,9 mm              | 9  | Additional drain flange, open |
| 2 | c to c distance   | 10 | Float pipe top end finish     |
| 3 | Design (indication rail)                                | 11 | Vent plug                     |
| 5 | Process connection side/side                            | 12 | Counter flanges               |
| 6 | Side studs welded with T-pieces for 100 % X-ray testing | 13 | Additional bracket            |
| 7 | Float removal flange                                    | 14 | Float pipe seamless           |
| 8 | Drain plug  | 15 | Float                         |

**Technical specifications magnetic level gauge type ITA-7**

Principle	:	Communicating tubes with magnetic float
Mounting position	:	vertical
Measuring range	:	<b>max. 5000 mm (one-part)</b> > 5000 mm 2- or multipart
Pipe diameter	:	<b>60,3 x 2,9 mm seamless, butt weld construction with T-pieces</b>
Process connection	:	to specify: <b>Flanges DN15-50 (1/2"-2"300#)</b> <b>welded or threaded stud</b>
Drain/vent connections	:	<b>plugged 1/2" NPT</b> <b>see price list</b>
Pipe material	:	<b>1.4404</b> , 1.4435, 1.4539, Hastelloy C4 (2.4610), Inconel 625 (2.4856), Inconel 825 (2.4858), Titan (3.7035) Other materials also possible (on request)
Flange material	:	as pipe material
Float material	:	<b>Titanium**</b> , Titanium/Halar-coated
Operation temperature	:	-50...+400 °C
Operation pressure	:	max. 64 bar
Operation density	:	min. 0,4243 kg/dm <sup>3</sup>
Bolts & Nuts	:	<b>CS</b> SS
Gasket	:	<b>Spiral wound, 316Ti</b> <b>Cam profile, 316Ti</b>
Indication rail	:	<b>Makrolon up to 120 °C</b> Aluminium up to 400 °C 1.4301 up to 400 °C
Float types	:	Cylindrical, sealed type Length: - <b>270 mm</b> - 330 mm - 530 mm - 630 mm
Dimensions	:	- A= 240* - B= 130 - C= 40

**Base equipment printed in bold letters!**

\* For densities < 0,682 kg/dm<sup>3</sup> enlarge the scale A

\*\* do not use for hydrogen or alcohol-compounds

### 3.14.2 ITA-7.0

Characteristics: **PN64 / Float pipe 1.4404; Flanges: CS**

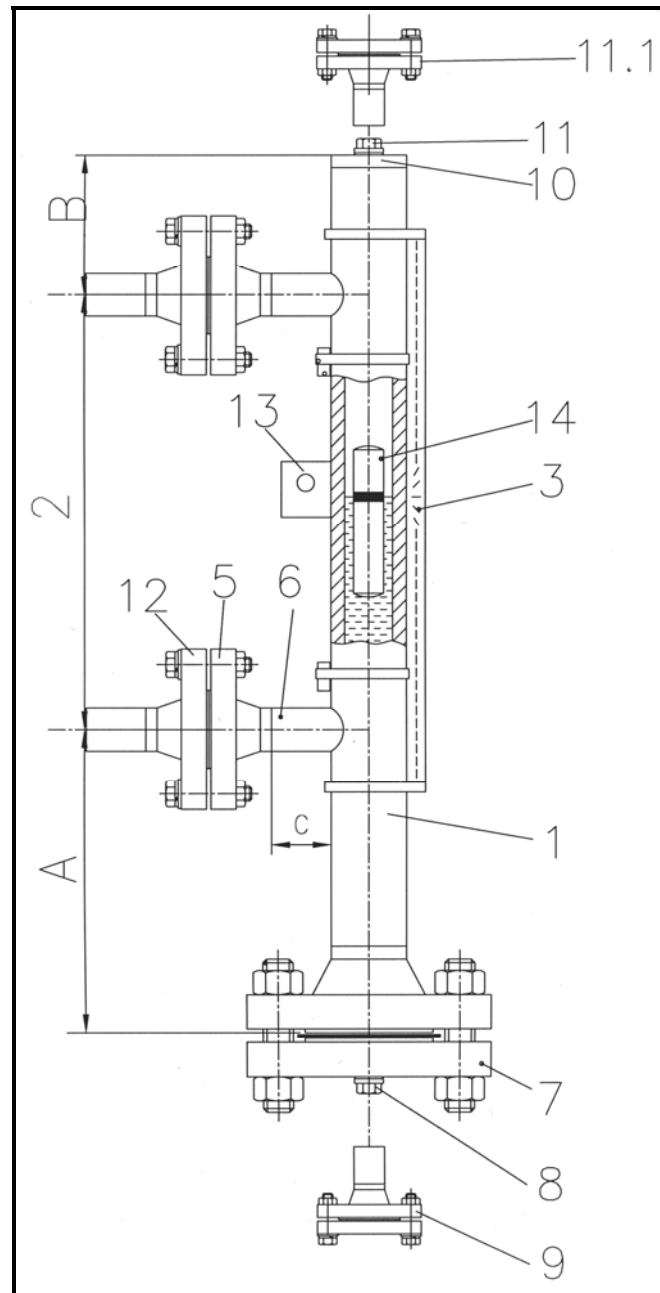

Parts drawing ITA-7.0

**Key:**

- |   |   |    |                               |
|---|---|----|-------------------------------|
| 1 | Float pipe welded Dimensions 60,3 x 2,9 mm              | 9  | Additional drain flange, open |
| 2 | c to c distance   | 10 | Float pipe top end finish     |
| 3 | Design (indication rail)                                | 11 | Vent plug                     |
| 5 | Process connection side/side                            | 12 | Counter flanges               |
| 6 | Side studs welded with T-pieces for 100 % X-ray testing | 13 | Additional bracket            |
| 7 | Float removal flange                                    | 14 | Float pipe seamless           |
| 8 | Drain plug  | 15 | Float                         |

### Technical specifications magnetic level gauge type ITA-7.0

Principle	:	Communicating tubes with magnetic float
Mounting position	:	vertical
Measuring range	:	<b>max. 5000 mm (one-part)</b> > 5000 mm 2- or multipart
Pipe diameter	:	<b>60,3 x 2,9 mm seamless, butt weld construction with T-pieces</b>
Process connection	:	to specify: <b>Flanges DN15-50 (1/2"-2"300#)</b> <b>welded or threaded stud</b>
Drain/vent connections	:	<b>plugged 1/2" NPT</b> <b>see price list</b>
Pipe material	:	<b>1.4404</b> , 1.4435, 1.4539, Hastelloy C4 (2.4610), Inconel 625 (2.4856), Inconel 825 (2.4858), Titan (3.7035) Other materials also possible (on request)
Flange material	:	<b>CS</b>
Float material	:	<b>Titanium**</b> , Titanium/Halar-coated
Operation temperature	:	-50...+400 °C
Operation pressure	:	max. 64 bar
Operation density	:	min. 0,4243 kg/dm <sup>3</sup>
Bolts & Nuts	:	<b>CS</b> SS
Gasket	:	<b>Spiral wound, 316Ti</b> <b>Cam profile, 316Ti</b>
Indication rail	:	<b>Makrolon up to 120 °C</b> Aluminium up to 400 °C 1.4301 up to 400 °C
Float types	:	Cylindrical, sealed type Length: - <b>270 mm</b> - 330 mm - 530 mm - 630 mm
Dimensions	:	- A= 240* - B= 130 - C= 40

**Base equipment printed in bold letters!**

\* For densities < 0,682 kg/dm<sup>3</sup> enlarge the scale A

\*\* do not use for hydrogen or alcohol-compounds

<b>Order codes for magnetic level gauge type ITA-7 and ITA-7.0</b>
--

Code	Description
<b>ITA-7 ITA-7.0</b>	<b>1. Float pipe seamless Dimensions 60,3 x 2,9 mm</b>
	<b>2. c to c distance</b>
<b>L</b>	c to c distance in mm
	<b>3. Design</b>
<b>0</b>	without indication rail
<b>1</b>	Indication rail material: Makrolon max. 120 °C
<b>2</b>	Indication rail material: Aluminium max. 400 °C
<b>3</b>	Indication rail material: 1.4401 max. 400 °C
	<b>4. c to c distance &lt; 5000 mm</b>
<b>A</b>	< 5000 mm - without flange connection; DN 50 PN 63
<b>B</b>	> 5000 mm - with flange connection; DN 50 PN 63
	<b>5. Process connection side/side</b>
<b>Y</b>	Welding connection (please specify)
<b>Z</b>	Threaded connection (please specify)
<b>1</b>	Flanges DN 15 PN 63
<b>2</b>	Flanges DN 20 PN 63
<b>3</b>	Flanges DN 25 PN 63
<b>4</b>	Flanges DN 32 PN 63
<b>5</b>	Flanges DN 40 PN 63
<b>6</b>	Flanges DN 50 PN 63
<b>A</b>	Flanges 1/2" ANSI 300 lbs
<b>B</b>	Flanges 3/4" ANSI 300 lbs
<b>C</b>	Flanges 1" ANSI 300 lbs
<b>D</b>	Flanges 1 1/4" ANSI 300 lbs
<b>E</b>	Flanges 1 1/2" ANSI 300 lbs
<b>F</b>	Flanges 2" ANSI 300 lbs
	<b>5.1 Surface side flanges</b>
<b>0</b>	without
<b>A</b>	Standard- Surface Form C
<b>B</b>	Standard-Surface RF
<b>D</b>	Surface Form E Rz=16
<b>E</b>	Surface RFSF (smooth finished)
<b>F</b>	Surface Nut (DIN2512)
<b>G</b>	Surface groove large
<b>H</b>	Surface Feder (DIN2512)
<b>K</b>	Surface tongue-large
<b>L</b>	Surface RTJ (ANSI) 1/2" bis 2"
	<b>6. Side studs welded with T-pieces for 100 % X-ray testing</b>
<b>0</b>	without
<b>T</b>	T-pieces
	<b>7. Float removal flange (bottom side)</b>
<b>1</b>	End cap (only if float removal flange (top side))
<b>2</b>	Flange DN 50 PN 63 incl. blind flange
<b>A</b>	Flange 2" ANSI 300 lbs incl. blind flange
<b>3</b>	Flange DN 50 PN 63 prepared for shut off valve on side
<b>B</b>	Flange 2" ANSI 300 lbs prepared for shut off valve on side

**Order codes for magnetic level gauge type ITA-7 and ITA-7.0 (Continuation)**

Code	Description
<b>7.1 Surface float removal flange (bottom side) (only DN50 or 2")</b>	
0	without (Float removal flange (bottom side) = end cap or < DN50 or 2")
A	Standard- Surface Form C
B	Standard-Surface RF
D	Surface Form E Rz=16
E	Surface RFSF (smooth finished)
F	Surface groove (DIN2512)
G	Surface groove large
H	Surface tongue (DIN2512)
K	Surface tongue-large
L	Surface RTJ (ANSI) 1/2" bis 2"
<b>7.2 Bolts &amp; Nuts float removal flange</b>	
0	without (Float removal flange (bottom side) = end cap)
1	M20 x 80 mm; mat. steel zincd; Flange DN 50 PN 63
2	M20 x 80 mm; mat. SS 1.4301; Flange DN 50 PN 63
3	M20 x 110 mm; mat. steel zincd; Flange 2510 DN50 PN63
4	M22 x 100 mm; mat. SS 1.4301; Flange DIN 2510 DN 50 PN 63
A	5/8" x 89 mm; mat. steel zincd A193B7 / A1942H; Flange 2" ANSI 300 lbs
B	5/8" x 89 mm; mat. SS A193B8 A1948M; Flange 2" ANSI 300 lbs
C	Bolts & Nuts PTFE-coated
<b>8. Drain plug</b>	
0	without
1	Drain plug 1/2" NPT
2	Drain plug 3/4" NPT
3	Drain plug 1" NPT
<b>9. Additional drain flange, open</b>	
0	without
1	Drain stud with flange DN 15 PN 63
2	Drain stud with flange DN 20 PN 63
3	Drain stud with flange DN 25 PN 63
4	Drain stud with flange DN 32 PN 63
5	Drain stud with flange DN 40 PN 63
A	Drain stud with flange 1/2" ANSI 300 lbs
B	Drain stud with flange 3/4" ANSI 300 lbs
C	Drain stud with flange 1" ANSI 300 lbs
D	Drain stud with flange 1 1/4" ANSI 300 lbs
E	Drain stud with flange 1 1/2" ANSI 300 lbs
<b>9.1 Drain flange with concentric reducer (X-ray testing)</b>	
0	ohne
1	DN 15 PN 63
2	DN 20 PN 63
3	DN 25 PN 63
4	DN 32 PN 63
5	DN 40 PN 63
A	1/2" ANSI 300 lbs
B	3/4" ANSI 300 lbs
C	1" ANSI 300 lbs
D	1 1/4" ANSI 300 lbs
E	1 1/2" ANSI 300 lbs

<b>Order codes for magnetic level gauge type ITA-7 and ITA-7.0 (Continuation)</b>
---

Code	Description
<b>9.2 Surface open drain flange</b>	
0	without (Float removal flange (bottom side) = end cap or < DN50 or 2")
A	Standard- Surface Form C
B	Standard-Surface RF
D	Surface Form E Rz=16
E	Surface RFSF (smooth finished)
F	Surface groove (DIN2512)
G	Surface groove large
H	Surface tongue (DIN2512)
K	Surface tongue-large
L	Surface RTJ (ANSI) 1/2" bis 2"
<b>10. Float pipe top end finish</b>	
1	End cap
2	Flange with blind flange DN 50 PN 63
A	Flange with blind flange 2" ANSI 300 lbs
<b>10.1 Surface float pipe top end finish flange (only DN50 or 2")</b>	
0	without (Float pipe top end finish = End cap or < DN50 or 2")
A	Standard- Surface Form C
B	Standard-Surface RF
D	Surface Form E Rz=16
E	Surface RFSF (smooth finished)
F	Surface groove (DIN2512)
G	Surface groove large
H	Surface tongue (DIN2512)
K	Surface tongue-large
L	Surface RTJ (ANSI) 1/2" bis 2"
<b>10.2 Bolts &amp; nuts float pipe top end finish flange</b>	
0	without (Float removal flange (bottom side) = end cap)
1	M20 x 80 mm; mat. steel zincd; Flange DN 50 PN 63
2	M20 x 80 mm; mat. SS 1.4301; Flange DN 50 PN 63
3	M20 x 110 mm; mat. steel zincd; Flange 2510 DN50 PN63
4	M22 x 100 mm; mat. SS 1.4301; Flange DIN 2510 DN 50 PN 63
A	5/8" x 89 mm; mat. steel zincd A193B7 / A1942H; Flange 2" ANSI 300 lbs
B	5/8" x 89 mm; mat. SS A193B8 A1948M; Flange 2" ANSI 300 lbs
C	Bolts & Nuts PTFE-coated
<b>11. Vent plug at top end</b>	
0	without
1	Vent plug G 1/2" DIN910
2	Vent plug 1/2" NPT
3	Vent plug 3/4" NPT
4	Vent plug 1" NPT

**Order codes for magnetic level gauge type ITA-7 and ITA-7.0 (Continuation)**

Code	Description
<b>11.1 Vent flange welded to end cap instead of vent plug</b>	
0	without
1	Flange DN 15 PN 63 (socket weld construction to endcap)
2	Flange DN 20 PN 63 (socket weld construction to end cap)
3	Flange DN 25 PN 63 (socket weld construction to end cap)
4	Flange DN 32 PN 63 (socket weld construction to end cap)
5	Flange DN 40 PN 63 (socket weld construction to end cap)
A	Flange 1/2" ANSI 300 lbs (socket weld construction to end cap)
B	Flange 3/4" ANSI 300 lbs (socket weld construction to end cap)
C	Flange 1" ANSI 300 lbs (socket weld construction to end cap)
D	Flange 1 1/4" ANSI 300 lbs (socket weld construction to end cap)
E	Flange 1 1/2" ANSI 300 lbs (socket weld construction to end cap)
<b>11.2 Vent flange with concentric reducer (X-ray testing)</b>	
0	without
1	DN 15 PN 63
2	DN 20 PN 63
3	DN 25 PN 63
4	DN 32 PN 63
5	DN 40 PN 63
A	1/2" ANSI 300 lbs
B	3/4" ANSI 300 lbs
C	1" ANSI 300 lbs
D	1 1/4" ANSI 300 lbs
E	1 1/2" ANSI 300 lbs
<b>11.3 Surface vent flange welded to end cap (only DN50 or 2")</b>	
0	without (Vent flange welded to end cap = without)
A	Standard- Surface Form C
B	Standard-Surface RF
D	Surface Form E Rz=16
E	Surface RFSF (smooth finished)
F	Surface groove (DIN2512)
G	Surface groove large
H	Surface tongue (DIN2512)
K	Surface tongue-large
L	Surface RTJ (ANSI) 1/2" bis 2"
<b>12. Counter flanges</b>	
0	without
1	DN 15 PN 63
2	DN 20 PN 63
3	DN 25 PN 63
4	DN 32 PN 63
5	DN 40 PN 63
6	DN 50 PN 63
A	1/2" ANSI 300 lbs
B	3/4" ANSI 300 lbs
C	1" ANSI 300 lbs
D	1 1/4" ANSI 300 lbs
E	1 1/2" ANSI 300 lbs
F	2" ANSI 300 lbs



**Order codes for magnetic level gauge type ITA-7 and ITA-7.0 (Continuation)**

Code	Description
<b>12.1 Surface counter flanges</b>	
0	without (Counter flanges = without)
A	Standard- Surface Form C
B	Standard-Surface RF
D	Surface Form E Rz=16
E	Surface RFSF (smooth finished)
F	Surface groove (DIN2512)
G	Surface groove large
H	Surface tongue (DIN2512)
K	Surface tongue-large
L	Surface RTJ (ANSI) 1/2" bis 2"
<b>12.2 Bolts &amp; Nuts counter flanges</b>	
0	without (Counter flanges = without)
1	M20 x 80 mm; mat. steel zincd; Flange DN 50 PN 63
2	M20 x 80 mm; mat. SS 1.4301; Flange DN 50 PN 63
3	M20 x 110 mm; mat. steel zincd; Flange 2510 DN50 PN63
4	M22 x 100 mm; mat. SS 1.4301; Flange DIN 2510 DN 50 PN 63
A	5/8" x 89 mm; mat. steel zincd A193B7 / A1942H; Flange 2" ANSI 300 lbs
B	5/8" x 89 mm; mat. SS A193B8 A1948M; Flange 2" ANSI 300 lbs
C	Bolts & Nuts PTFE-coated
<b>13. Additional bracket welded to the float pipe</b>	
0	without
H	Bracket
<b>14. Schwimmer</b>	
F7K2SY	50,8 x 270; material: Titanium*; pressure max. 64 bar min. density of liquid: 0,682 kg/dm <sup>3</sup>
G7K2SY	50,8 x 330; material: Titanium*; pressure max. 64 bar min. density of liquid: 0,6064 kg/dm <sup>3</sup>
K7K2SY	50,8 x 530; material: Titanium*; pressure max. 64 bar min. density of liquid: 0,4450 kg/dm <sup>3</sup>
L7K2SY	50,8 x 630; material: Titanium*; pressure max. 64 bar min. density of liquid: 0,4243 kg/dm <sup>3</sup>

1	2	3	4	5	6	7	8	9	10	11	12	13	14					
ITA-7	L= mm													7	K	2	S	Y

1	2	3	4	5	6	7	8	9	10	11	12	13	14					
ITA-7.0	L= mm													7	K	2	S	Y

**3.15.1 ITA-8.1**

Characteristics: **PN6 / Material: PVC**

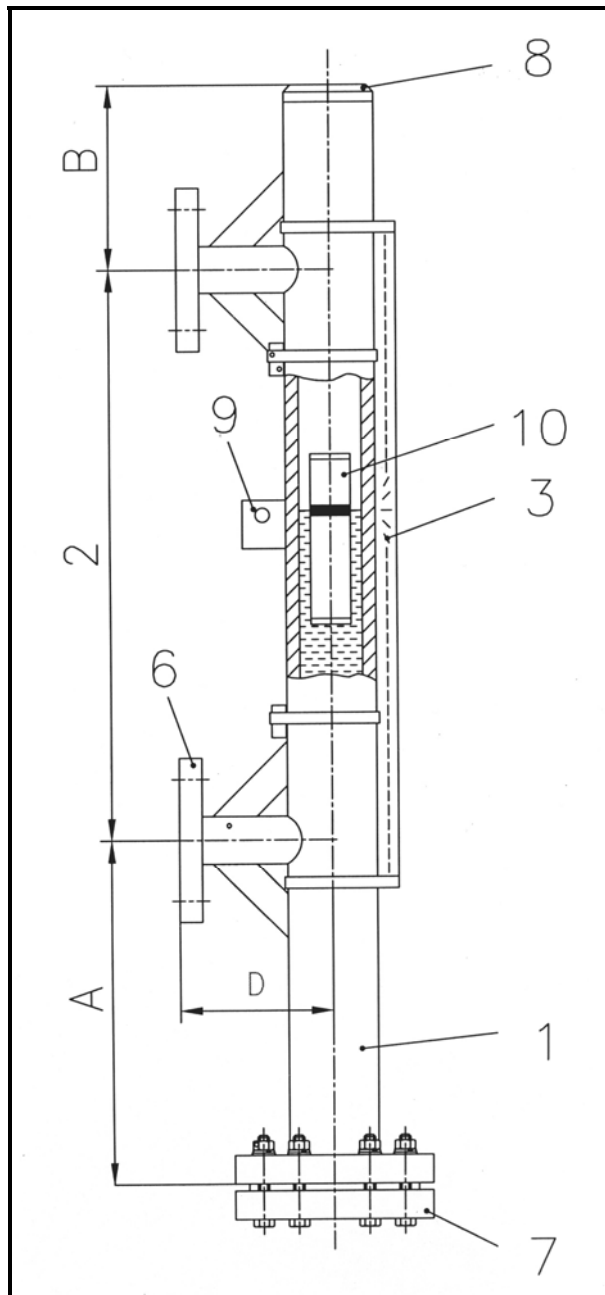

Parts drawing ITA-8.1

**Key:**

- 1 Float pipe PVC Dimensions 63 x 4,7 mm
- 2 c to c distance
- 3 Design (indication rail)
- 6 Process connections side / side
- 7 Drain plug
- 8 Float pipe top end finish
- 9 Mounting link
- 10 Float

<b>Technical specification magnetic level gauge type ITA-8.1</b>
--

Principle	:	Communicating tubes with magnetic float
Mounting position	:	vertical
Measuring range	:	<b>max. 5000 mm (one-part)</b> > 5000 mm 2- or multipart
Pipe diameter	:	<b>63 x 4,7 mm</b>
Process connection	:	to specify: <b>Flanges DN15-50 (1/2"-2")</b>
Drain/vent connections	:	<b>plugged R 1/2"</b> <b>see price list</b>
Pipe material	:	<b>PVC</b>
Flange material	:	as pipe material
Float material	:	<b>PVC</b>
Operation temperature	:	-30...+60 °C
Operation pressure	:	max. 6 bar
Operation density	:	min. 0,75 kg/dm <sup>3</sup>
Bolts & Nuts	:	<b>SS</b>
Gasket	:	<b>Viton</b>
Indication rail	:	<b>Aluminium</b> 316SS
Float types	:	Cylindrical, sealed type Length: - <b>255 mm</b> - 135 mm
Dimensions	:	- A= 240* - B= 130 - C= 110

**Base equipment printed in bold letters!**

\* For densities < 0,75 kg/dm<sup>3</sup> enlarge the scale A

**Order codes for magnetic level gauge type ITA-8.1**

Code	Description
<b>ITA-8.1</b>	<b>1. Float pipe PVC Dimensions 63 x 4,7 mm</b>
	<b>2. C to C distance</b>
<b>L</b>	C to C distance in mm
	<b>3. Design</b>
<b>0</b>	without indication rail, each
<b>1</b>	Indication rail material Aluminium, max. 60 °C liquid temperature
<b>2</b>	Indication rail material 1.4401, max. 60 °C liquid temperature
	<b>4. C to C distance &lt; 5000 mm</b>
<b>A</b>	< 5000 without flange connection DN 32 PN 6
<b>B</b>	> 5000 with flange connection DN32 PN 6
	<b>5. Reinforcement</b>
<b>0</b>	without reinforcement
<b>A</b>	Reinforcement of the PVC-guide tube, material: 1.4404, base price + length dependent price each 100 mm guide tube
	<b>6. Process connections side/side</b>
<b>Y</b>	Welding connection (please specify)
<b>Z</b>	Threaded connection (please specify)
<b>1</b>	Flanges DN 15 PN 6
<b>2</b>	Flanges DN 15 PN 10
<b>3</b>	Flanges DN 20 PN 6
<b>4</b>	Flanges DN 20 PN 10
<b>5</b>	Flanges DN 25 PN 6
<b>6</b>	Flanges DN 25 PN 10
<b>7</b>	Flanges DN 32 PN 6
<b>8</b>	Flanges DN 32 PN 10
<b>9</b>	Flanges DN 40 PN 6
<b>A</b>	Flanges DN 40 PN 10
<b>B</b>	Flanges DN 50 PN 6
<b>C</b>	Flanges DN 50 PN 10
<b>D</b>	Flanges 1/2" ANSI 150 lbs
<b>E</b>	Flanges 3/4" ANSI 150 lbs
<b>F</b>	Flanges 1" ANSI 150 lbs
<b>G</b>	Flanges 1 1/4" ANSI 150 lbs
<b>H</b>	Flanges 1 1/2" ANSI 150 lbs
<b>K</b>	Flanges 2" ANSI 150 lbs
	<b>7. Drain plug</b>
<b>0</b>	without
<b>1</b>	Drain plug R1/2"
<b>2</b>	Drain plug 1/2" NPT
<b>3</b>	Drain plug 3/4" NPT
<b>4</b>	Stud on blind flange

**Order codes for magnetic level gauge type ITA-8.1 (Continuation)**

Code	Description
<b>8. Float pipe top end finish</b>	
0	without
A	End cap
B	Vent plug R1/2"
C	Vent plug 1/2" NPT
D	Vent plug 3/4" NPT
E	Flange DN32 PN6
<b>8.1 Nuts &amp; bolts top end finish flange</b>	
0	without
1	M8 x 60 mm; mat. SS 1.4301; DIN 931
<b>9. Mounting link for additional fixing on the tank</b>	
0	without
H	Mounting link for additional fixing on the tank
<b>10. Float</b>	
E6B6SY	255 x 50 mm, min. density of liquid: 0,75 kg/dm <sup>3</sup> , material: PVC

<b>1</b>	<b>2</b>	<b>3</b>	<b>4</b>	<b>5</b>	<b>6</b>	<b>7</b>	<b>8</b>	<b>9</b>	<b>10</b>					
ITA-8.1	L=                      mm								E	6	B	6	S	Y

**3.15.2 ITA-8.2**

Characteristics: PN6 / Material: PP

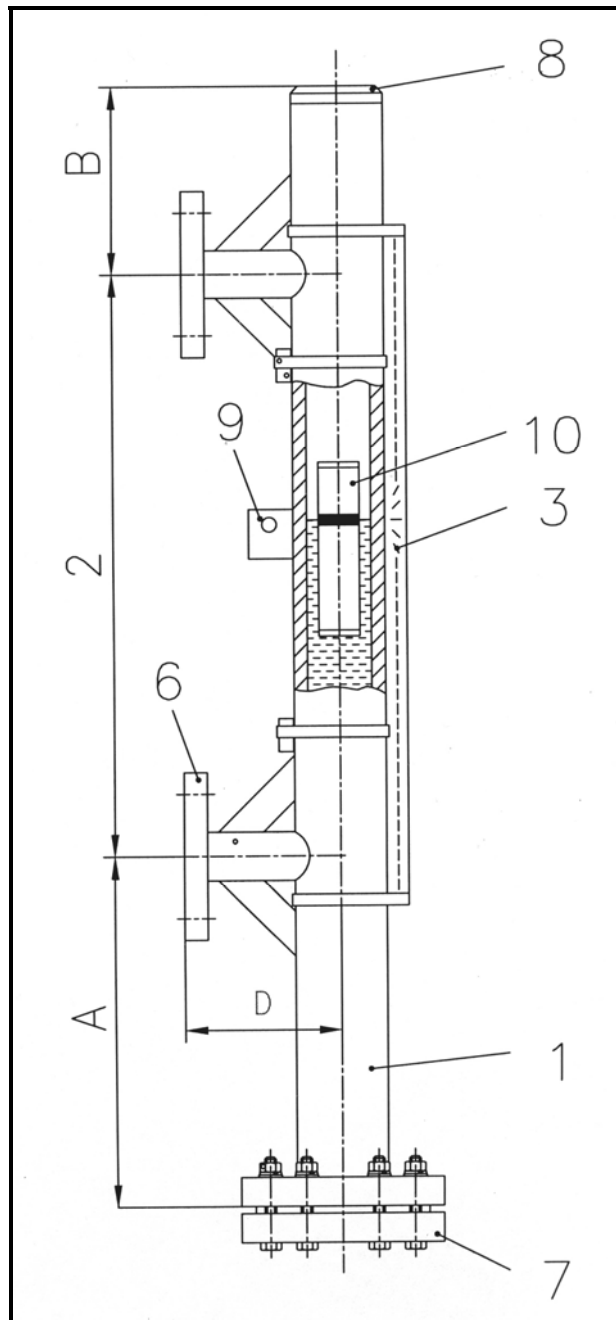

Parts drawing ITA-8.2

**Key:**

- 1 Float pipe PP Dimensions 63 x 4,7 mm
- 2 c to c distance
- 3 Design (indication rail)
- 6 Process connections side / side
- 7 Drain plug
- 8 Float pipe top end finish
- 9 Mounting link
- 10 Float

### Technical specifications magnetic level gauge type ITA-8.2

Principle	:	Communicating tubes with magnetic float
Mounting position	:	vertical
Measuring range	:	<b>max. 5000 mm (one-part)</b> > 5000 mm 2- or multipart
Pipe diameter	:	<b>63 x 3,6 mm</b>
Process connection	:	to specify: <b>Flanges DN15-50 (1/2"-2")</b>
Drain/vent connections	:	<b>plugged R 1/2"</b> <b>see price list</b>
Pipe material	:	<b>PP</b>
Flange material	:	as pipe material
Float material	:	<b>PP</b>
Operation temperature	:	-10...+80 °C
Operation pressure	:	max. 6 bar
Operation density	:	min. 0,65 kg/dm <sup>3</sup>
Bolts & Nuts	:	<b>SS</b>
Gasket	:	<b>Viton</b>
Indication rail	:	<b>Aluminium</b> 316SS
Float types	:	Cylindrical, sealed type Length: - <b>255 mm</b> - 135 mm
Dimensions	:	- A= 240* - B= 130 - C= 110

**Base equipment printed in bold letters!**

\* For densities < 0,65 kg/dm<sup>3</sup> enlarge the scale A

**Order codes for magnetic level gauge type ITA-8.2**

Code	Description
<b>ITA-8.1</b>	<b>1. Float pipe PP Dimensions 63 x 4,7 mm</b>
	<b>2. C to C distance</b>
<b>L</b>	C to C distance in mm
	<b>3. Design</b>
<b>0</b>	without indication rail
<b>1</b>	Indication rail material Aluminium, max. 80 °C liquid temperature
<b>2</b>	Indication rail material 1.4401, max. 80 °C liquid temperature
	<b>4. C to C distance &lt; 5000 mm</b>
<b>A</b>	< 5000 without flange connection DN 32 PN 6
<b>B</b>	> 5000 with flange connection DN32 PN 6
	<b>5. Reinforcement</b>
<b>0</b>	without reinforcement
<b>A</b>	Reinforcement of the PP-guide tube, material: 1.4404, base price + length dependent price each 100 mm guide tube
	<b>6. Process connections side/side</b>
<b>Y</b>	Welding connection (please specify)
<b>Z</b>	Threaded connection (please specify)
<b>1</b>	Flanges DN 15 PN 6
<b>2</b>	Flanges DN 15 PN 10
<b>3</b>	Flanges DN 20 PN 6
<b>4</b>	Flanges DN 20 PN 10
<b>5</b>	Flanges DN 25 PN 6
<b>6</b>	Flanges DN 25 PN 10
<b>7</b>	Flanges DN 32 PN 6
<b>8</b>	Flanges DN 32 PN 10
<b>9</b>	Flanges DN 40 PN 6
<b>A</b>	Flanges DN 40 PN 10
<b>B</b>	Flanges DN 50 PN 6
<b>C</b>	Flanges DN 50 PN 10
<b>D</b>	Flanges 1/2" ANSI 150 lbs
<b>E</b>	Flanges 3/4" ANSI 150 lbs
<b>F</b>	Flanges 1" ANSI 150 lbs
<b>G</b>	Flanges 1 1/4" ANSI 150 lbs
<b>H</b>	Flanges 1 1/2" ANSI 150 lbs
<b>K</b>	Flanges 2" ANSI 150 lbs
	<b>7. Drain plug</b>
<b>0</b>	without
<b>1</b>	Drain plug R1/2"
<b>2</b>	Drain plug 1/2" NPT
<b>3</b>	Drain plug 3/4" NPT



**Order codes for magnetic level gauge type ITA-8.2 (Continuation)**

Code	Description
	<b>8. Float pipe top end finish</b>
A	End cap
B	Vent plug R1/2"
C	Vent plug 1/2" NPT
D	Vent plug 3/4" NPT
E	Flange DN32 PN6
	<b>8.1 Nuts &amp; bolts top end finish flange</b>
0	without
1	M8 x 60 mm; mat. SS 1.4301; DIN 931
	<b>9. Mounting link for additional fixing on the tank</b>
0	without
1	Mounting link for additional fixing on the tank
	<b>10. Float</b>
E6A7SY	255 x 50 mm, min. density of liquid: 0,65 kg/dm <sup>3</sup> , material: PP

1	2	3	4	5	6	7	8	9	10					
ITA-8.2	L=                      mm								E	6	A	7	S	Y

**3.15.3 ITA-8.3**

Characteristics: **PN6 / Material: PVDF**

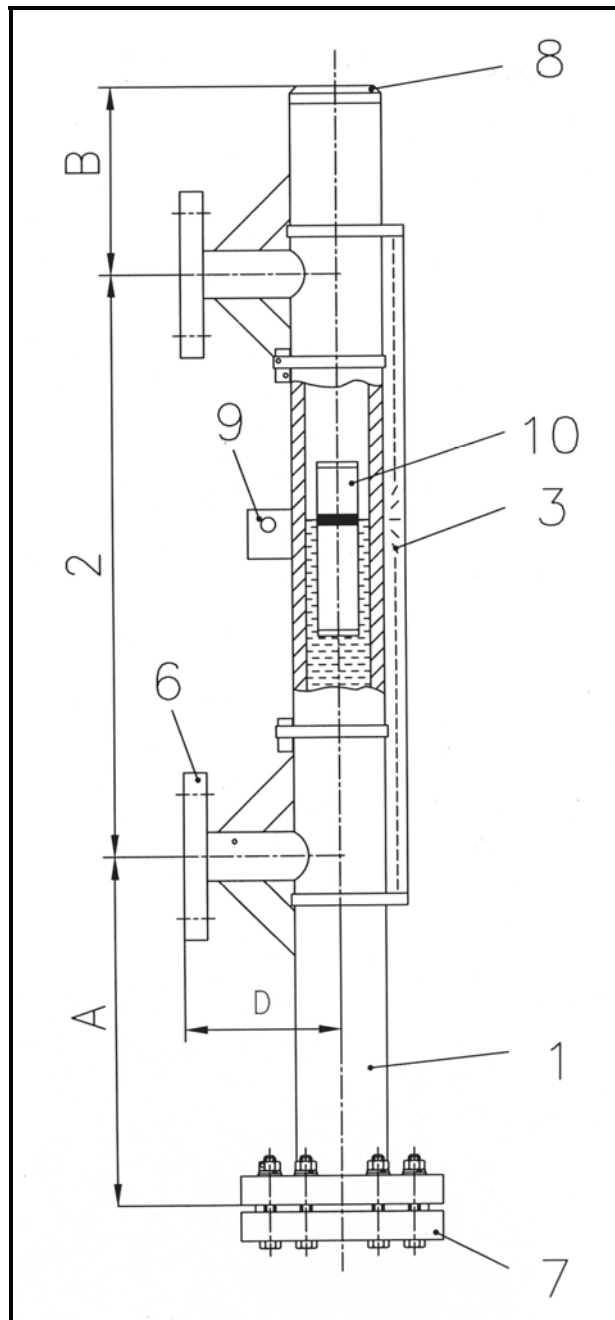

Parts drawing ITA-8.3

**Key:**

- 1 Float pipe PVDF Dimensions 63 x 3 mm
- 2 c to c distance
- 3 Design (indication rail)
- 6 Process connections side / side
- 7 Drain plug
- 8 Float pipe top end finish
- 9 Mounting link
- 10 Float

### Technical specifications magnetic level gauge type ITA-8.3

Principle	:	Communicating tubes with magnetic float
Mounting position	:	vertical
Measuring range	:	<b>max. 5000 mm (one-part)</b> > 5000 mm 2- or multipart
Pipe diameter	:	<b>63 x 3 mm</b>
Process connection	:	to specify: <b>Flanges DN15-50 (1/2"-2")</b>
Drain/vent connections	:	<b>plugged R 1/2"</b> <b>see price list</b>
Pipe material	:	<b>PVDF</b>
Flange material	:	as pipe material
Float material	:	<b>PVDF</b>
Operation temperature	:	-40...+120 °C
Operation pressure	:	max. 6 bar
Operation density	:	min. 0,85 kg/dm <sup>3</sup>
Bolts & Nuts	:	<b>SS</b>
Gasket	:	<b>Viton</b>
Indication rail	:	<b>Aluminium</b> 316SS
Float types	:	Cylindrical, sealed type Length: - <b>255 mm</b> - 135 mm
Dimensions	:	- A= 240* - B= 130 - C= 110

**Base equipment printed in bold letters!**

\* For densities < 0,85 kg/dm<sup>3</sup> enlarge the scale A

**Order codes for magnetic level gauge type ITA-8.3**

Code	Description
<b>ITA-8.3</b>	<b>1. Float pipe PVDF Dimernsions 63 x 3 mm</b>
	<b>2. C to C distance</b>
<b>L</b>	C to C distance in mm
	<b>3. Design</b>
<b>0</b>	without indication rail
<b>1</b>	Indication rail material Aluminium, max. 120 °C liquid temperature
<b>2</b>	Indication rail material 1.4401, max. 120 °C liquid temperature
	<b>4. C to C distance &lt; 5000 mm</b>
<b>A</b>	< 5000 without flange connection DN 32 PN 6
<b>B</b>	> 5000 with flange connection DN32 PN 6
	<b>5. Reinforcement</b>
<b>0</b>	without reinforcement
<b>A</b>	Reinforcement of the PVDF-guide tube, material: 1.4404, base price + length dependent price each 100 mm guide tube
	<b>6. Process connections side/side</b>
<b>Y</b>	Welding connection (please specify)
<b>Z</b>	Threaded connection (please specify)
<b>1</b>	Flanges DN 15 PN 6
<b>2</b>	Flanges DN 15 PN 10
<b>3</b>	Flanges DN 20 PN 6
<b>4</b>	Flanges DN 20 PN 10
<b>5</b>	Flanges DN 25 PN 6
<b>6</b>	Flanges DN 25 PN 10
<b>7</b>	Flanges DN 32 PN 6
<b>8</b>	Flanges DN 32 PN 10
<b>9</b>	Flanges DN 40 PN 6
<b>A</b>	Flanges DN 40 PN 10
<b>B</b>	Flanges DN 50 PN 6
<b>C</b>	Flanges DN 50 PN 10
<b>D</b>	Flanges 1/2" ANSI 150 lbs
<b>E</b>	Flanges 3/4" ANSI 150 lbs
<b>F</b>	Flanges 1" ANSI 150 lbs
<b>G</b>	Flanges 1 1/4" ANSI 150 lbs
<b>H</b>	Flanges 1 1/2" ANSI 150 lbs
<b>K</b>	Flanges 2" ANSI 150 lbs
	<b>7. Drain plug</b>
<b>0</b>	without
<b>1</b>	Drain plug R1/2"
<b>2</b>	Drain plug 1/2" NPT
<b>3</b>	Drain plug 3/4" NPT

**Order codes for magnetic level gauge type ITA-8.3 (Continuation)**

Code	Description
<b>8. Float pipe top end finish</b>	
A	End cap
B	Vent plug R1/2"
C	Vent plug 1/2" NPT
D	Vent plug 3/4" NPT
E	Flange DN32 PN6
<b>8.1 Nuts &amp; bolts top end finish flange</b>	
0	without
1	M8 x 60 mm; mat. SS 1.4301; DIN 931
<b>9. Mounting link for additional fixing on the tank</b>	
0	without
1	Mounting link for additional fixing on the tank
<b>10. Float</b>	
E6E8SY	255 x 50 mm, min. density of liquid: 0,75 kg/dm <sup>3</sup> , material: PVDF

1	2	3	4	5	6	7	8	9	10						
ITA-8.3	L=                      mm									E	6	E	8	S	Y

**3.16.1 ITA-9.1. PVC**

Characteristics: **PN 6 / Material: PVC**

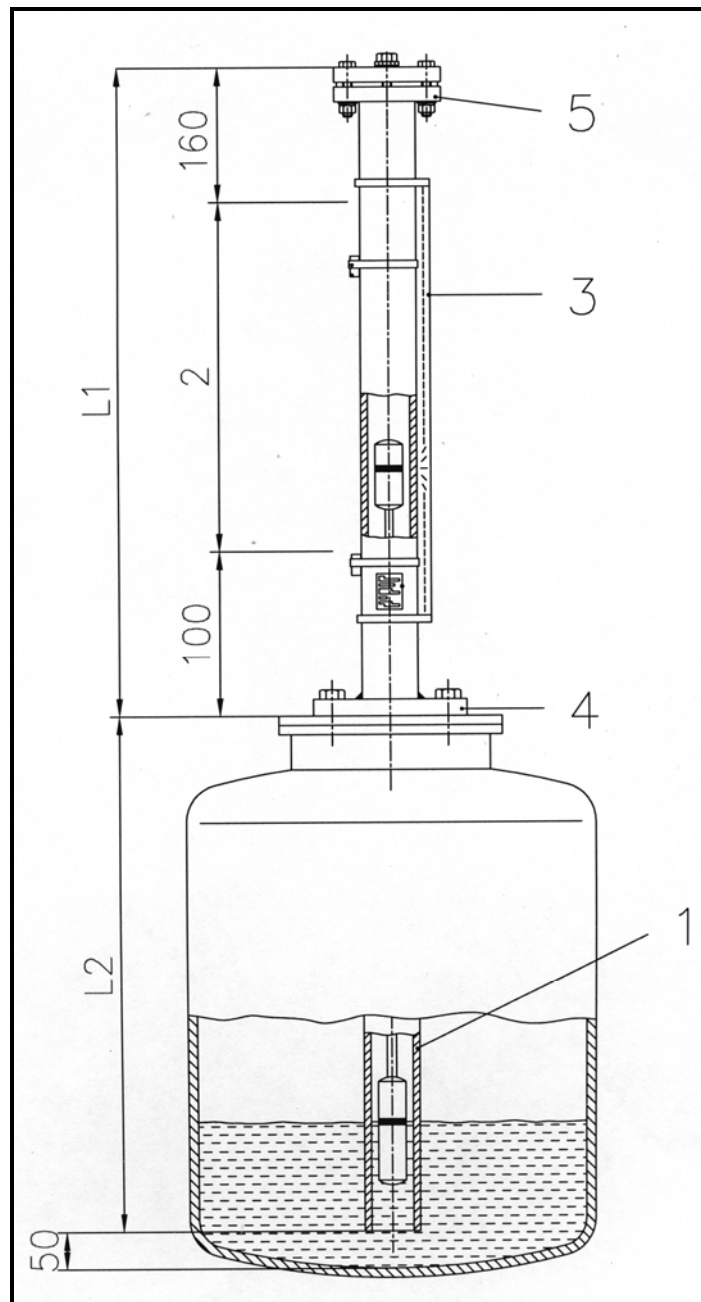

Parts drawing ITA-9.1

**Key:**

- 1 Float pipe welded Dimensions 63 x 4,7 mm
- 2 Measuring length
- 3 Design (indication rail)
- 4 Process connection on tank
- 5 Follower magnet guide tube topside finish

**Technical specification magnetic level gauge type ITA-9.1**

Principle	:	Communicating tubes with magnetic float
Mounting position	:	top of tank
Measuring range	:	<b>max. 5000 mm (one-part)</b> > 5000 mm 2- or multipart
Pipe diameter	:	<b>63 x 4,7 mm</b>
Process connection	:	Flanged DN80 (3") Flanged DN100-DN150 (4"-6")
Vent connections	:	<b>Flanged DN32 PN6</b>
Pipe material	:	<b>PVC</b>
Flange material	:	as pipe material
Float material	:	<b>PVC</b>
Operation temperature	:	-30...+50 °C
Operation pressure	:	max. 6 bar
Operation density	:	min. 0,7 kg/dm <sup>3</sup> (depending on the measuring length)
Bolts & Nuts	:	<b>SS</b>
Gasket	:	<b>Viton</b>
Indication rail	:	<b>Aluminium</b> 316SS
Float types	:	Cylindrical, sealed type, with rod Length: <ul style="list-style-type: none"><li>- <b>250 mm</b></li><li>- (special sizes available)</li></ul>

**Base equipment printed in bold letters!**

**Order codes for magnetic level gauge type ITA-9.1**

Code	Description
<b>ITA-9.1</b>	<b>1. Float pipe Dimensions 63 x 4,7 mm</b>
	<b>2. Measuring length</b>
<b>L</b>	Measuring length in mm (max. 2500 mm, depending on the liquid's density)
	<b>3. Design</b>
<b>0</b>	without indication rail
<b>1</b>	Indication rail material Aluminium, max. 60 °C liquid temperature
<b>2</b>	Indication rail material 1.4401, max. 60 °C liquid temperature
	<b>4. Process connection onto Tank (FF)</b>
<b>1</b>	Flange DN 80/PN 6
<b>2</b>	Flange DN 100/PN 6
<b>3</b>	Flange DN 150/PN 6
<b>A</b>	Flange 3" ANSI/150 lbs
<b>B</b>	Flange 4" ANSI/150 lbs
<b>C</b>	Flange 6" ANSI/150 lbs
	<b>5. Follower magnet guide tube topside finish</b>
<b>1</b>	Vent plug R1/2"
<b>2</b>	Vent plug 1/2"NPT
<b>3</b>	Vent plug 3/4" NPT
<b>4</b>	Flange with blind flange DN32 PN 6

<b>1</b>	<b>2</b>	<b>3</b>	<b>4</b>	<b>5</b>
ITA-9.1	L=            mm			



**3.16.2 ITA-9.2 PP**

Characteristics: PN 6 / Material: PP

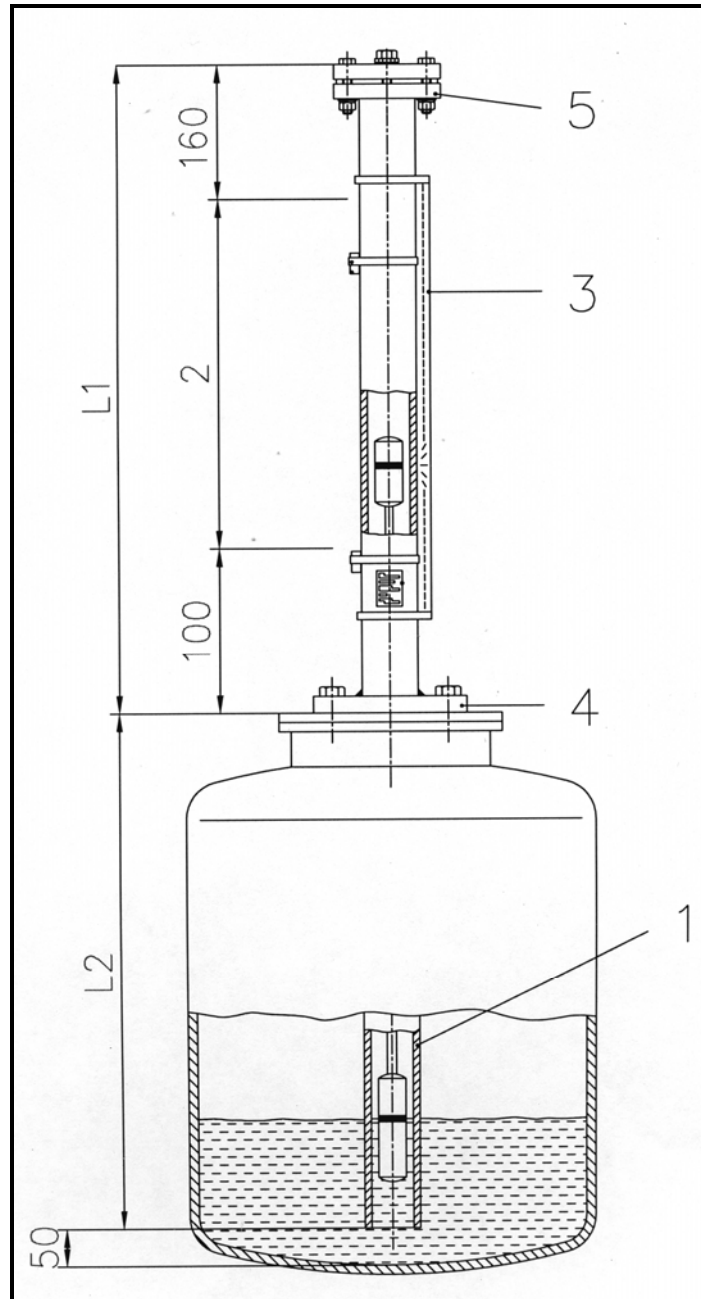

Parts drawing ITA-9.2

**Key:**

- 1 Float pipe welded Dimensions 63 x 3,6 mm
- 2 Measuring length
- 3 Design (indication rail)
- 4 Process connection on tank
- 5 Follower magnet guide tube topside finish

**Technical specification magnetic level gauge type ITA-9.2**

Principle	:	Communicating tubes with magnetic float
Mounting position	:	top of tank
Measuring range	:	<b>max. 5000 mm (one-part)</b> > 5000 mm 2- or multipart
Pipe diameter	:	<b>63 x 3,6 mm</b>
Process connection	:	Flanged DN80 (3") Flanged DN100-DN150 (4"-6")
Vent connections	:	<b>Flanged DN32 PN6</b>
Pipe material	:	<b>PP</b>
Flange material	:	as pipe material
Float material	:	<b>PP</b>
Operation temperature	:	-10...+80 °C
Operation pressure	:	max. 6 bar
Operation density	:	min. 0,7 kg/dm <sup>3</sup> (depending on the measuring length)
Bolts & Nuts	:	<b>SS</b>
Gasket	:	<b>Viton</b>
Indication rail	:	<b>Aluminium</b> 316SS
Float types	:	Cylindrical, sealed type, with rod Length: <ul style="list-style-type: none"><li>- <b>250 mm</b></li><li>- (special sizes available)</li></ul>

**Base equipment printed in bold letters!**

<b>Order codes for magnetic level gauge type ITA-9.2</b>
--

Code	Description
<b>ITA-9.2</b>	<b>1. Float pipe Dimensions 63 x 3,6 mm</b>
	<b>2. Measuring length</b>
<b>L</b>	Measuring length in mm (max. 2500 mm, depending on the liquid's density)
	<b>3. Design</b>
<b>0</b>	without indication rail
<b>1</b>	Indication rail material Aluminium, max. 80 °C liquid temperature
<b>2</b>	Indication rail material 1.4401, max. 80 °C liquid temperature
	<b>4. Process connection onto Tank (FF)</b>
<b>1</b>	Flange DN 80/PN 6
<b>2</b>	Flange DN 100/PN 6
<b>3</b>	Flange DN 150/PN 6
<b>A</b>	Flange 3" ANSI/150 lbs
<b>B</b>	Flange 4" ANSI/150 lbs
<b>C</b>	Flange 6" ANSI/150 lbs
	<b>5. Follower magnet guide tube topside finish</b>
<b>1</b>	Vent plug R1/2"
<b>2</b>	Vent plug 1/2"NPT
<b>3</b>	Vent plug 3/4" NPT
<b>4</b>	Flange with blind flange DN32 PN 6

<b>1</b>	<b>2</b>	<b>3</b>	<b>4</b>	<b>5</b>
ITA-9.2	L=            mm			

**3.16.3 ITA-9.3 PVDF**

Characteristics: PN 6 / Material: PVDF

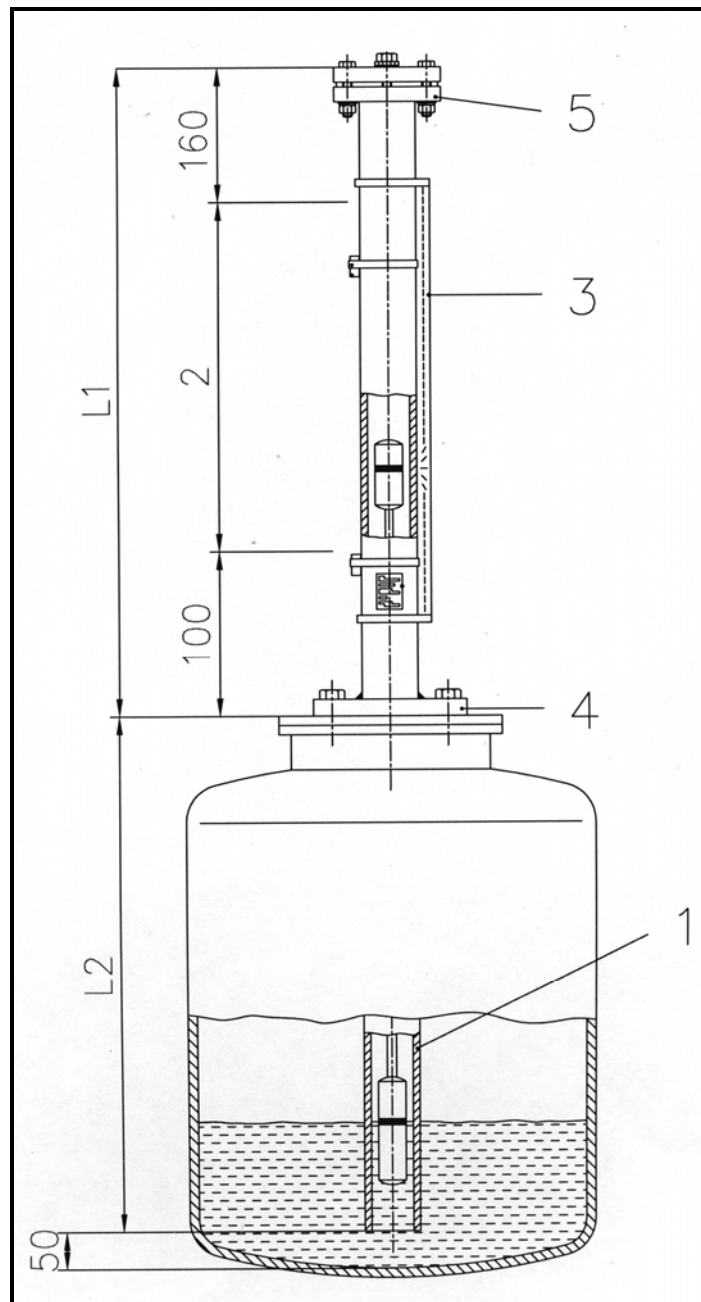

Parts drawing ITA-9.3

**Key:**

- 1 Float pipe welded Dimensions 63 x 3 mm
- 2 Measuring length
- 3 Design (indication rail)
- 4 Process connection on tank
- 5 Follower magnet guide tube topside finish

### Technical specification magnetic level gauge type ITA-9.3

Principle	:	Communicating tubes with magnetic float
Mounting position	:	top of tank
Measuring range	:	<b>max. 5000 mm (one-part)</b> > 5000 mm 2- or multipart
Pipe diameter	:	<b>63 x 3 mm</b>
Process connection	:	Flanged DN80 (3") Flanged DN100-DN150 (4"-6")
Vent connections	:	<b>Flanged DN32 PN6</b>
Pipe material	:	<b>PVDF</b>
Flange material	:	as pipe material
Float material	:	<b>PVDF</b>
Operation temperature	:	-40...+120 °C
Operation pressure	:	max. 6 bar
Operation density	:	min. 0,7 kg/dm <sup>3</sup> (depending on the measuring length)
Bolts & Nuts	:	<b>SS</b>
Gasket	:	<b>Viton</b>
Indication rail	:	<b>Aluminium</b> 316SS
Float types	:	Cylindrical, sealed type, with rod Length: - <b>250 mm</b> - (special sizes available)

**Base equipment printed in bold letters!**

**Order codes for magnetic level gauge type ITA-9.3**

Code	Description
<b>ITA-9.3</b>	<b>1. Float Pipe Dimensions 63 x 3 mm</b>
	<b>2. Measuring length</b>
<b>L</b>	Measuring length in mm (max. 2500 mm, depending on the liquid's density)
	<b>3. Design</b>
<b>0</b>	without indication rail
<b>1</b>	Indication rail material Aluminium, max. 120 °C liquid temperature
<b>2</b>	Indication rail material 1.4401, max. 120 °C liquid temperature
	<b>4. Process connection onto tank (FF)</b>
<b>1</b>	Flange DN 80/PN 6
<b>2</b>	Flange DN 100/PN 6
<b>3</b>	Flange DN 150/PN 6
<b>A</b>	Flange 3" ANSI/150 lbs
<b>B</b>	Flange 4" ANSI/150 lbs
<b>C</b>	Flange 6" ANSI/150 lbs
	<b>5. Follower magnet guide tube topside finish</b>
<b>1</b>	Vent plug R1/2"
<b>2</b>	Vent plug 1/2"NPT
<b>3</b>	Vent plug 3/4" NPT
<b>4</b>	Flange with blind flange DN32 PN 6

<b>1</b>	<b>2</b>	<b>3</b>	<b>4</b>	<b>5</b>
ITA-9.3	L=            mm			

### 3.17.1 ITA-10

Characteristics: **PN100 / Float pipe and flange material 1.4404**

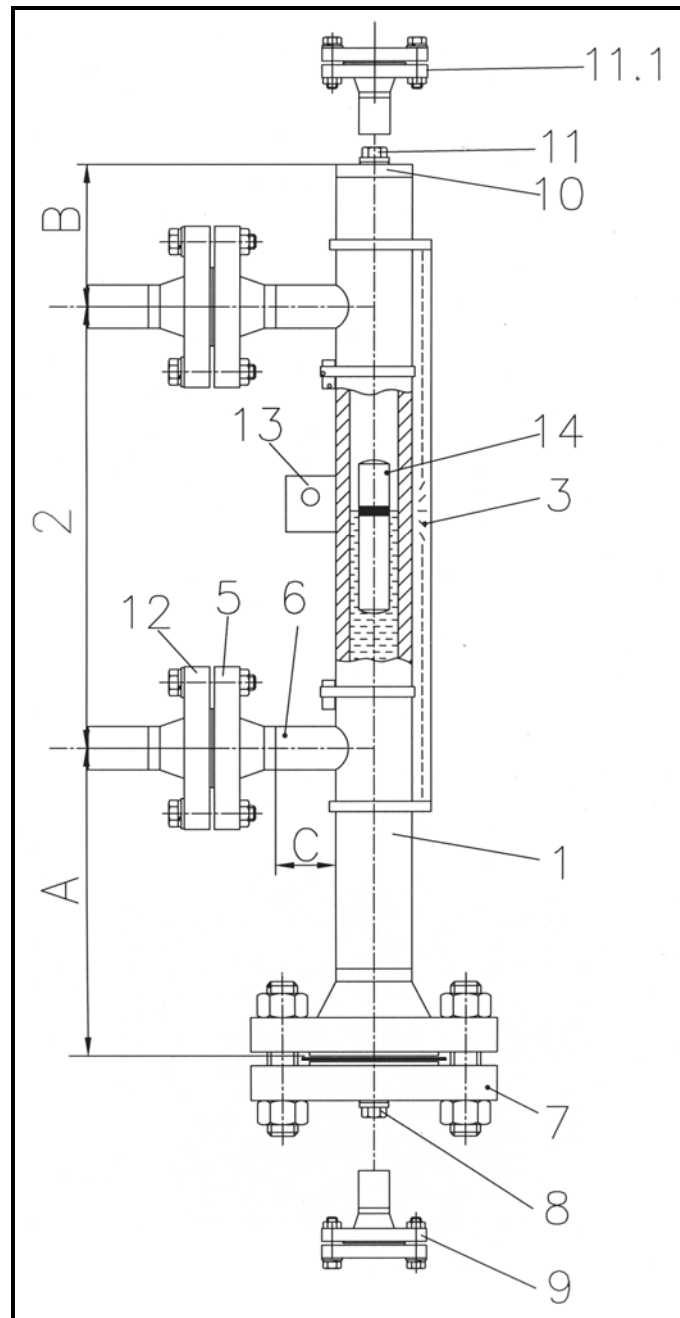

Parts drawing ITA-10

**Key:**

- |   |   |    |                               |
|---|---|----|-------------------------------|
| 1 | Float pipe welded Dimensions 60,3 x 3,2 mm              | 9  | Additional drain flange, open |
| 2 | c to c distance   | 10 | Float pipe top end finish     |
| 3 | Design (indication rail)                                | 11 | Vent plug                     |
| 5 | Process connection side/side                            | 12 | Counter flanges               |
| 6 | Side studs welded with T-pieces for 100 % X-ray testing | 13 | Additional bracket            |
| 7 | Float removal flange                                    | 14 | Float pipe seamless           |
| 8 | Drain plug  | 15 | Float                         |

**Technical specifications magnetic level gauge type ITA-10**

Principle	:	Communicating tubes with magnetic float
Mounting position	:	vertical
Measuring range	:	<b>max. 5000 mm (one-part)</b> > 5000 mm 2- or multipart
Pipe diameter	:	<b>60,3 x 3,2 mm seamless,</b> <b>With studs</b> or butt weld construction with T-pieces
Process connection	:	to specify: <b>Flanges DN15-50 (1/2"-2"600#),</b> <b>Welding or threaded stud</b>
Drain/vent connections	:	<b>Plug 1/2" NPT</b> (for more please see price list)
Pipe material	:	<b>1.4404</b> , 1.4435, 1.4539, Hastelloy C4 (2.4610), Inconel 625 (2.4856), Inconel 825 (2.4858), Titan (3.7035) Other materials also possible (on request)
Flange material	:	same as pipe material
Float material	:	<b>Titanium</b> , Titan/Halar-coated
Operation temperature	:	-50...+400 °C
Operation pressure	:	max.100 bar
Operation density	:	min. 0,4632 kg/dm <sup>3</sup>
Bolts & Nuts	:	<b>CS</b> SS
Gasket	:	<b>Spiral wound, 316Ti</b> <b>Cam profile, 316Ti</b>
Indication rail	:	<b>Makrolon up to 120 °C</b> Aluminium up to 400 °C 1.4301 up to 400 °C
Float types	:	Cylindrical, sealed type Length: - <b>270 mm</b> - 330 mm - 430 mm - 530 mm - 630 mm
Standard dimensions	:	- A = 240* - B = 130** - C = 70

**Base equipment printed in bold letters!**

**\* for densities < 0,7011 kg/dm<sup>3</sup> enlarge the scale A**

**\*\* for end cap B=170 mm for WN**



### 3.17.2 ITA-10.0

Characteristics: **PN100 / Float pipe: 1.4404; Flanges CS**

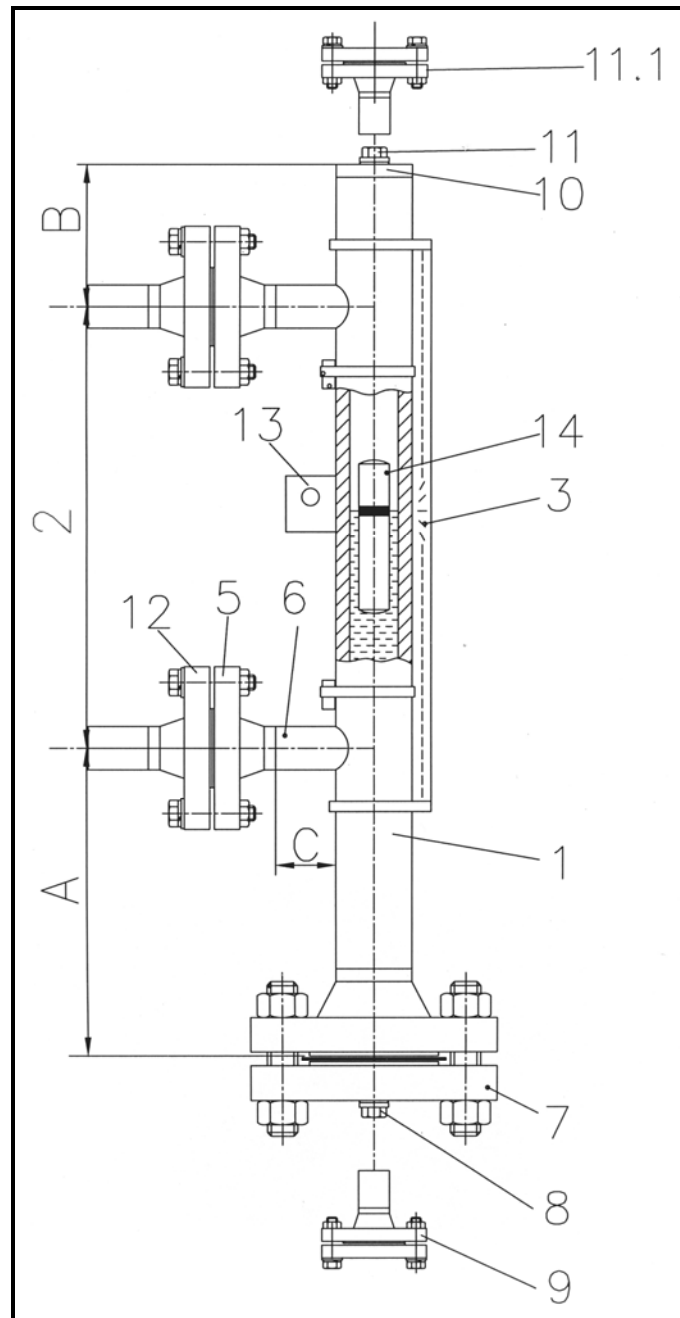

Parts drawing ITA-10.0

**Key:**

- |   |   |    |                               |
|---|---|----|-------------------------------|
| 1 | Float pipe welded Dimensions 60,3 x 3,2 mm              | 9  | Additional drain flange, open |
| 2 | c to c distance   | 10 | Float pipe top end finish     |
| 3 | Design (indication rail)                                | 11 | Vent plug                     |
| 5 | Process connection side/side                            | 12 | Counter flanges               |
| 6 | Side studs welded with T-pieces for 100 % X-ray testing | 13 | Additional bracket            |
| 7 | Float removal flange                                    | 14 | Float pipe seamless           |
| 8 | Drain plug  | 15 | Float                         |

**Technical specifications magnetic level gauge type ITA-10.0**

Principle	:	Communicating tubes with magnetic float
Mounting position	:	vertical
Measuring range	:	<b>max. 5000 mm (one-part)</b> > 5000 mm 2- or multipart
Pipe diameter	:	<b>60,3 x 3,2 mm seamless,</b> <b>With studs</b> or butt weld construction with T-pieces
Process connection	:	to specify: <b>Flanges DN15-50 (1/2"-2"600#),</b> <b>Welding or threaded stud</b>
Drain/vent connections	:	<b>Plug 1/2" NPT</b> (for more please see price list)
Pipe material	:	<b>1.4404, 1.4435, 1.4539, Hastelloy C4 (2.4610),</b> Inconel 625 (2.4856), Inconel 825 (2.4858), Titan (3.7035) Other materials also possible (on request)
Flange material	:	<b>CS</b>
Float material	:	<b>Titanium, Titan/Halar-coated</b>
Operation temperature	:	-50...+400 °C
Operation pressure	:	max.100 bar
Operation density	:	min. 0,4632 kg/dm <sup>3</sup>
Bolts & Nuts	:	<b>CS</b> SS
Gasket	:	<b>Spiral wound, 316Ti</b> <b>Cam profile, 316Ti</b>
Indication rail	:	<b>Makrolon up to 120 °C</b> Aluminium up to 400 °C 1.4301 up to 400 °C
Float types	:	Cylindrical, sealed type Length: - <b>270 mm</b> - 330 mm - 430 mm - 530 mm - 630 mm
Standard dimensions	:	- A = 240* - B = 130** - C = 70

**Base equipment printed in bold letters!**

**\* for densities < 0,7011 kg/dm<sup>3</sup> enlarge the scale A**

**\*\* for end cap B=170 mm for WN**

<b>Order codes for magnetic level gauge type ITA-10 and ITA-10.0</b>
--

Code	Description
<b>ITA-10</b>	<b>1. Float pipe seamless</b>
<b>ITA-10.0</b>	<b>Dimensions 60,3 x 3,2 mm</b>
<b>2. C to C distance</b>	
<b>L</b>	C to C distance in mm
<b>3. Design</b>	
<b>0</b>	without indication rail
<b>1</b>	Indication rail material: Makrolon max. 120 °C
<b>2</b>	Indication rail material: Aluminium max. 400 °C
<b>3</b>	Indication rail material: 1.4401 max. 400 °C
<b>4. C to C distance &lt; 5000 mm</b>	
<b>A</b>	< 5000 mm - without flange connection; DN 50 PN 100
<b>B</b>	> 5000 mm - with flange connection; DN 50 PN 100
<b>5. Process connections side/side</b>	
<b>Y</b>	Welded connection (please specify)
<b>Z</b>	Threaded connection (please specify)
<b>1</b>	Flanges DN 15 PN 100
<b>2</b>	Flanges DN 25 PN 100
<b>3</b>	Flanges DN 32 PN 100
<b>4</b>	Flanges DN 40 PN 100
<b>5</b>	Flanges DN 50 PN 100
<b>A</b>	Flanges 1/2" ANSI 600 lbs
<b>B</b>	Flanges 3/4" ANSI 600 lbs
<b>C</b>	Flanges 1" ANSI 600 lbs
<b>D</b>	Flanges 1 1/4" ANSI 600 lbs
<b>E</b>	Flanges 1 1/2" ANSI 600 lbs
<b>F</b>	Flanges 2" ANSI 600 lbs
<b>5.1 Surface side flanges</b>	
<b>0</b>	without
<b>B</b>	Standard-Surface RF
<b>D</b>	Surface Form E Rz=16
<b>E</b>	Surface RFSF (smooth finished)
<b>F</b>	Surface groove (DIN2512)
<b>G</b>	Surface groove large
<b>H</b>	Surface tongue (DIN2512)
<b>K</b>	Surface tongue-large
<b>L</b>	Surface RTJ (ANSI)
<b>6. Side studs welded with T-pieces for 100 % X-ray testing</b>	
<b>0</b>	without
<b>1</b>	T-pieces
<b>7. Float removal flange (bottom side)</b>	
<b>1</b>	Flange DN 50 PN 100 incl. blind flange
<b>2</b>	Flange 2" ANSI 600 lbs incl. blind flange
<b>3</b>	Flange DN 50 PN 100 prepared for shut off valve on side
<b>4</b>	Flange 2" ANSI 600 lbs prepared for shut off valve on side

**Order codes for magnetic level gauge type ITA-10 and ITA-10.0 (Continuation)**

Code	Description
<b>7.1 Surface float removal flange (bottom side) (only DN50 or 2")</b>	
B	Standard-Surface RF
D	Surface Form E Rz=16
E	Surface RFSF (smooth finished)
F	Surface groove (DIN2512)
G	Surface groove large
H	Surface tongue (DIN2512)
K	Surface tongue-large
L	Surface RTJ (ANSI)
<b>7.2 Bolts &amp; Nuts float removal flange</b>	
1	M24 x 120 mm; material CK35/C35 zincd DIN2510; Flange DN 50 PN 100
2	M24 x 120 mm; material A2-70 DIN2510; Flange DN 50 PN 100
A	5/8" x 108 mm; material A193B7 / A1942H zincd; Flange 2" ANSI 600 lbs RF
B	5/8" x 108 mm; material A193B7 / A1942H PTFE coated; Flange 2" ANSI 600 lbs RF
C	5/8" x 108 mm; material A193B8 / A1948M SS; Flange 2" ANSI 600 lbs RF
<b>8. Drain plug</b>	
0	without
1	Drain plug G 1/2" with soft iron gasket
2	Drain plug 1/2" NPT
3	Drain plug 3/4" NPT
4	Drain plug 1" NPT
<b>9. Additional drain flange, open</b>	
0	without
1	Drain stud with flange DN 15 PN 100
2	Drain stud with flange DN 25 PN 100
3	Drain stud with flange DN 32 PN 100
4	Drain stud with flange DN 40 PN 100
A	Drain stud with flange 1/2" ANSI 600 lbs
B	Drain stud with flange 3/4" ANSI 600 lbs
C	Drain stud with flange 1" ANSI 600 lbs
D	Drain stud with flange 1 1/4" ANSI 600 lbs
E	Drain stud with flange 1 1/2" ANSI 600 lbs
<b>9.1 Drain flange with concentric reducer (X-ray testing)</b>	
0	without
1	DN 15 PN 100
2	DN 25 PN 100
3	DN 32 PN 100
4	DN 40 PN 100
A	1/2" ANSI 600 lbs
B	3/4" ANSI 600 lbs
C	1" ANSI 600 lbs
D	1 1/4" ANSI 600 lbs
E	1 1/2" ANSI 600 lbs

**Order codes for magnetic level gauge type ITA-10 and ITA-10.0 (Continuation)**

Code	Description
<b>9.2 Surface open drain flange</b>	
0	without
B	Standard-Surface RF
D	Surface Form E Rz=16
E	Surface RFSF (smooth finished)
F	Surface groove (DIN2512)
G	Surface groove large
H	Surface tongue (DIN2512)
K	Surface tongue-large
L	Surface RTJ (ANSI)
<b>10. Float pipe top end finish</b>	
0	End Cap
1	Flange with blind flange DN 50 PN 100
A	Flange with blind flange 2" ANSI 600 lbs
<b>10.1 Surface float pipe top end finish flange (only DN50 or 2")</b>	
0	without
B	Surface Form E Rz=16
D	Surface groove (DIN2512)
E	Surface tongue (DIN2512)
F	Dichtleiste RF - RA = 3,2 bis 6,3
G	Surface RFSF (ANSI)
H	Surface groove large ANSI
K	Surface tongue-large ANSI
L	Surface RTJ (ANSI)
<b>10.2 Bolts &amp; nuts float pipe top end finish flange</b>	
0	without
1	M24 x 120 mm; material CK35/C35 zincd DIN2510; Flange DN 50 PN 100
2	M24 x 120 mm; material A2-70 DIN2510; Flange DN 50 PN 100
A	5/8" x 108 mm; material A193B7 / A1942H zincd; Flange 2" ANSI 600 lbs RF
B	5/8" x 108 mm; material A193B7 / A1942H PTFE coated; Flange 2" ANSI 600 lbs RF
C	5/8" x 108 mm; material A193B8 / A1948M SS; Flange 2" ANSI 600 lbs RF
<b>11. Vent plug at top end</b>	
0	without
1	Vent plug G 1/2" with soft iron gasket
2	Vent plug 1/2" NPT
3	Vent plug 3/4" NPT
4	Vent plug 1" NPT
<b>11.1 Vent flange welded to end cap instead of vent plug</b>	
0	without
1	Flange DN 15 PN 100 (socket weld construction to endcap)
2	Flange DN 25 PN 100 (socket weld construction to endcap)
3	Flange DN 32 PN 100 (socket weld construction to endcap)
4	Flange DN 40 PN 100 (socket weld construction to endcap)
A	Flange 1/2" ANSI 600 lbs (socket weld construction to endcap)
B	Flange 3/4" ANSI 600 lbs (socket weld construction to endcap)
C	Flange 1" ANSI 600 lbs (socket weld construction to endcap)
D	Flange 1 1/4" ANSI 600 lbs (socket weld construction to endcap)
E	Flange 1 1/2" ANSI 600 lbs (socket weld construction to endcap)

**Order codes for magnetic level gauge type ITA-10 and ITA-10.0 (Continuation)**

Code	Description
<b>11.2 Vent flange with concentric reducer (X-ray testing)</b>	
0	without
1	DN 15 PN 100
2	DN 25 PN 100
3	DN 32 PN 100
4	DN 40 PN 100
A	1/2" ANSI 600 lbs
B	3/4" ANSI 600 lbs
C	1" ANSI 600 lbs
D	1 1/4" ANSI 600 lbs
E	1 1/2" ANSI 600 lbs
<b>11.3 Surface vent flange welded to end cap (only DN50 or 2")</b>	
0	without
B	Surface Form E Rz=16
D	Surface groove (DIN2512)
E	Surface tongue (DIN2512)
F	Standard-Surface RF
G	Surface RFSF (smooth finished)
H	Surface groove large
K	Surface tongue-large
L	Surface RTJ (ANSI)
<b>12. Counter flanges</b>	
0	without
1	DN 15 PN 100
2	DN 25 PN 100
3	DN 32 PN 100
4	DN 40 PN 100
5	DN 50 PN 100
A	1/2" 600 lbs
B	3/4" 600 lbs
C	1" 600 lbs
D	1 1/4" 600 lbs
E	1 1/2" 600 lbs
F	2" 600 lbs
12.1 Surface counter flanges	
0	without
B	Surface Form E Rz=16
D	Surface groove (DIN2512)
E	Surface tongue (DIN2512)
F	Standard-Surface RF
G	Surface RFSF (smooth finished)
H	Surface groove large
K	Surface tongue-large
L	Surface RTJ (ANSI)

**Order codes for magnetic level gauge type ITA-10 and ITA-10.0 (Continuation)**

Code	Description
<b>12.2 Bolts &amp; Nuts counter flanges</b>	
0	without
1	M24 x 120 mm; material CK35/C35 zincd DIN2510; Flange DN 50 PN 100
2	M24 x 120 mm; material A2-70 DIN2510; Flange DN 50 PN 100
3	5/8" x 108 mm; material A193B7 / A1942H zincd; Flange 2" ANSI 600 lbs RF
4	5/8" x 108 mm; material A193B7 / A1942H PTFE coated; Flange 2" ANSI 600 lbs RF
5	5/8" x 108 mm; material A193B8 / A1948M SS; Flange 2" ANSI 600 lbs RF
<b>13. Additional bracket welded to the float pipe</b>	
0	without
H	Bracket
<b>14. Float</b>	
<b>F7L2SY</b>	50,8 x 270 material Titanium, pressure max. 100 bar min. density of liquid: 0,8299 kg/dm <sup>3</sup> sealed
<b>F8L1SY</b>	52 x 270 material: 1.4571 pressure max. 100 bar min. density of liquid: 0,7283 kg/dm <sup>3</sup>
<b>G7L2SY</b>	50,8 x 330 material: Titanium pressure max. 100 bar min. density of liquid: 0,7617 kg/dm <sup>3</sup> sealed
<b>H7L2SY</b>	50,8 x 430 material: Titanium pressure max. 100 bar min. density of liquid: 0,6779 kg/dm <sup>3</sup> sealed
<b>K7L2SY</b>	50,8 x 530 material: Titanium pressure max. 100 bar min. density of liquid: 0,6321 kg/dm <sup>3</sup> sealed
<b>L7V2SY</b>	50,8 x 630 material: Titanium pressure max. 80 bar min density of liquid: 0,4632 kg/dm <sup>3</sup> sealed
<b>F7L2SH</b>	50,8 x 270 material Titanium, pressure max. 100 bar min. density of liquid: 0,7 kg/dm <sup>3</sup> sealed Float for high temperature applications

1	2	3	4	5	6	7	8	9	10	11	12	13	14	
ITA-10	L=.....mm													S

1	2	3	4	5	6	7	8	9	10	11	12	13	14	
ITA-10.0	L=.....mm													S

**3.18.1 ITA-11**

Characteristics: **PN160 / Float pipe and flange material 1.4404**

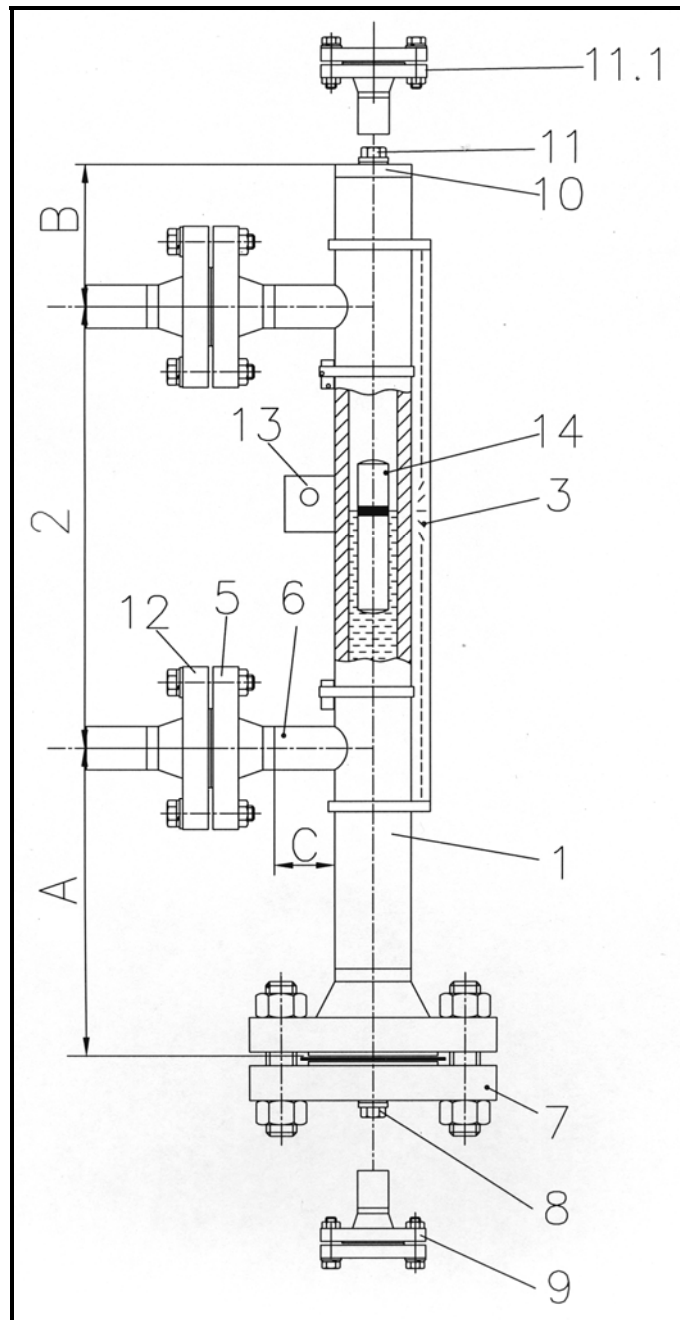

Parts drawing ITA-11

**Key:**

- |   |   |    |                               |
|---|---|----|-------------------------------|
| 1 | Float pipe welded Dimensions 60,3 x 3,91 mm             | 9  | Additional drain flange, open |
| 2 | c to c distance   | 10 | Float pipe top end finish     |
| 3 | Design (indication rail)                                | 11 | Vent plug                     |
| 5 | Process connection side/side                            | 12 | Counter flanges               |
| 6 | Side studs welded with T-pieces for 100 % X-ray testing | 13 | Additional bracket            |
| 7 | Float removal flange                                    | 14 | Float pipe seamless           |
| 8 | Drain plug  | 15 | Float                         |



## Technical specification magnetic level gauge type ITA-11

Principle	:	Communicating tubes with magnetic float
Mounting position	:	vertical
Measuring range	:	<b>max. 5000 mm (one-part)</b> > 5000 mm 2- or multipart
Pipe diameter	:	<b>60,3 x 3,91 mm seamless,</b> <b>60,3 x 3,6 mm seamless,</b> <b>welding stud</b> or butt weld construction with T-pieces
Process connection	:	to specify: <b>Flanges DN15-50 (1/2"-2"1500#),</b> <b>Welding or threaded stud</b>
Drain/vent connections	:	<b>Plug 1/2" NPT</b> (for more please see price list)
Pipe material	:	<b>1.4404</b> , 1.4435, 1.4539, Hastelloy C4 (2.4610), Inconel 625 (2.4856), Inconel 825 (2.4858), Titan (3.7035) Other materials also possible (on request)
Flange material	:	same as pipe material
Float material	:	<b>316 Ti</b> , Titanium
Operation temperature	:	-50...+400 °C
Operation pressure	:	max.160 bar
Operation density	:	min. 0,6008 kg/dm <sup>3</sup> (sealed type)
Bolts & Nuts	:	<b>CS</b> SS
Gasket	:	<b>Spiral wound, 316SS</b> <b>Cam profile, 316SS</b>
Indication rail	:	<b>Makrolon up to 120 °C</b> Aluminium up to 400 °C 1.4301 up to 400 °C
Float types	:	Cylindrical, vented type Length: - <b>270 mm</b> - 210 mm - 330 mm - 430 mm - 530 mm
Standard dimensions	:	- A = 240* - B = 130** - C = 70

**Base equipment printed in bold letters!**

**\* for densities < 0,7324 kg/dm<sup>3</sup> enlarge the scale A**

**\*\* for end cap B=170 mm for WN**

**3.18.2 ITA-11.0**

Characteristics: **PN160 / Float pipe: 1.4404; Flanges: CS**

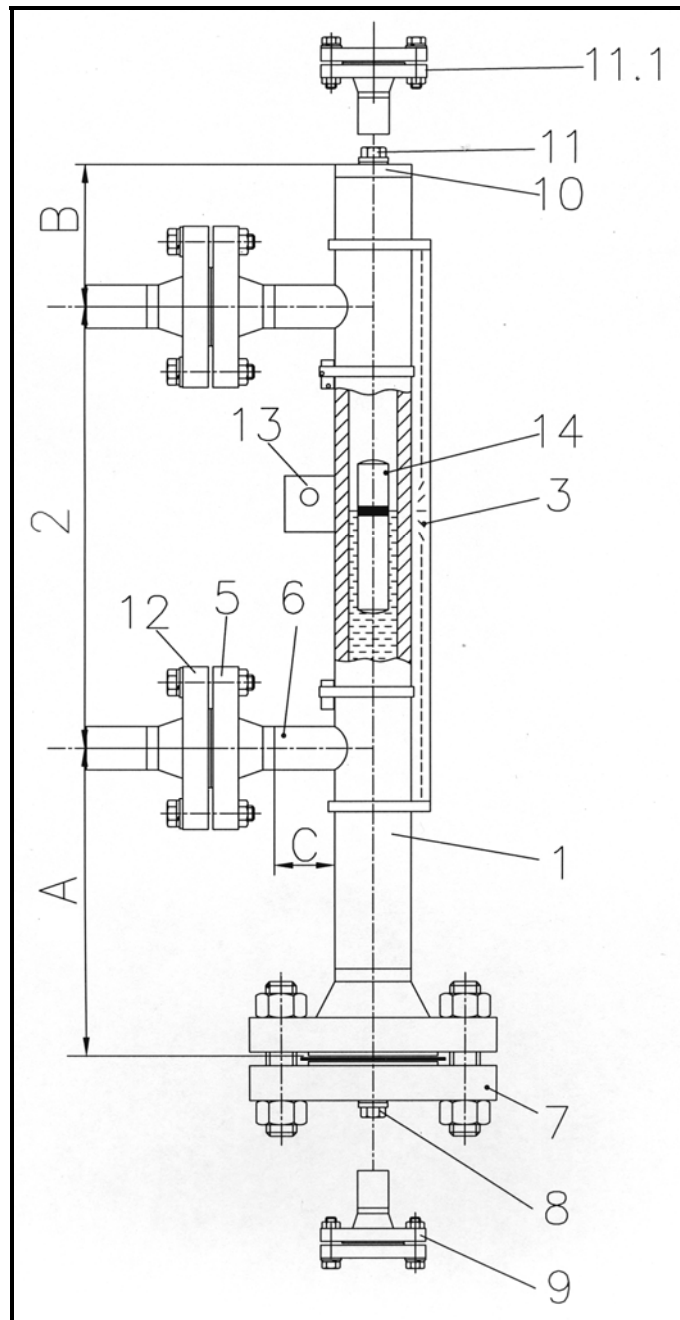

Parts drawing ITA-11.0

**Key:**

- |   |   |    |                               |
|---|---|----|-------------------------------|
| 1 | Float pipe welded Dimensions 60,3 x 3,91 mm             | 9  | Additional drain flange, open |
| 2 | c to c distance   | 10 | Float pipe top end finish     |
| 3 | Design (indication rail)                                | 11 | Vent plug                     |
| 5 | Process connection side/side                            | 12 | Counter flanges               |
| 6 | Side studs welded with T-pieces for 100 % X-ray testing | 13 | Additional bracket            |
| 7 | Float removal flange                                    | 14 | Float pipe seamless           |
| 8 | Drain plug  | 15 | Float                         |

## Magnetic level gauge type ITA-11.0

Principle	:	Communicating tubes with magnetic float
Mounting position	:	vertical
Measuring range	:	<b>max. 5000 mm (one-part)</b> > 5000 mm 2- or multipart
Pipe diameter	:	<b>60,3 x 3,91 mm seamless,</b> <b>60,3 x 3,6 mm seamless,</b> <b>welding stud</b> or butt weld construction with T-pieces
Process connection	:	to specify: <b>Flanges DN15-50 (1/2"-2"1500#),</b> <b>Welding or threaded stud</b>
Drain/vent connections	:	<b>Plug 1/2" NPT</b> (for more please see price list)
Pipe material	:	<b>1.4404</b> , 1.4435, 1.4539, Hastelloy C4 (2.4610), Inconel 625 (2.4856), Inconel 825 (2.4858), Titan (3.7035) Other materials also possible (on request)
Flange material	:	<b>CS</b>
Float material	:	<b>316 Ti</b> , Titanium
Operation temperature	:	-50...+400 °C
Operation pressure	:	max. 160 bar
Operation density	:	min. 0,6008 kg/dm <sup>3</sup> (sealed type)
Bolts & Nuts	:	<b>CS</b> SS
Gasket	:	<b>Spiral wound, 316SS</b> <b>Cam profile, 316SS</b>
Indication rail	:	<b>Makrolon up to 120 °C</b> Aluminium up to 400 °C 1.4301 up to 400 °C
Float types	:	Cylindrical, vented type Length: - <b>270 mm</b> - 210 mm - 330 mm - 430 mm - 530 mm
Standard dimensions	:	- A = 240* - B = 130** - C = 70

**Base equipment printed in bold letters!**

**\* for densities < 0,7324 kg/dm<sup>3</sup> enlarge the scale A**

**\*\* for end cap B=170 mm for WN**

<b>Order codes for magnetic level gauge type ITA-11 and ITA-11.0</b>
--

Code	Description
<b>ITA-11 ITA-11.0</b>	<b>1. Float pipe seamless Dimensions 60,3 x 3,91 mm</b>
	<b>2. C to C distance</b>
<b>L</b>	C to C distance in mm
	<b>3. Design</b>
<b>0</b>	without indication rail
<b>1</b>	Indication rail material: Makrolon max. 120 °C
<b>2</b>	Indication rail material: Aluminium max. 400 °C
<b>3</b>	Indication rail material: 1.4401 max. 400 °C
	<b>4. C to C distance &lt; 5000 mm</b>
<b>A</b>	< 5000 mm - without flange connection; DN 50 PN 160
<b>B</b>	> 5000 mm - with flange connection; DN 50 PN 160
	<b>5. Process connections side/side</b>
<b>Y</b>	welding connection (please specify)
<b>Z</b>	threaded connection (please specify)
<b>1</b>	Flanges DN 15 PN 160
<b>2</b>	Flanges DN 25 PN 160
<b>3</b>	Flanges DN 32 PN 160
<b>4</b>	Flanges DN 50 PN 160
<b>A</b>	Flanges 1/2" ANSI 1500 lbs
<b>B</b>	Flanges 3/4" ANSI 1500 lbs
<b>C</b>	Flanges 1" ANSI 1500 lbs
<b>D</b>	Flanges 1 1/4" ANSI 1500 lbs
<b>E</b>	Flanges 1 1/2" ANSI 1500 lbs
<b>F</b>	Flanges 2" ANSI 1500 lbs
	<b>5.1 Surface side flanges</b>
<b>0</b>	without
<b>B</b>	Standard-Surface RF
<b>D</b>	Surface Form E Rz=16
<b>E</b>	Surface RFSF (smooth finished)
<b>F</b>	Surface groove (DIN2512)
<b>G</b>	Surface groove large
<b>H</b>	Surface tongue (DIN2512)
<b>K</b>	Surface tongue-large
<b>L</b>	Surface RTJ (ANSI)
	<b>6. Side studs welded with T-pieces for 100 % X-ray testing</b>
<b>0</b>	without
<b>T</b>	T-pieces
	<b>7. Float removal flange (bottom side)</b>
<b>1</b>	Flange DN 50 PN 160 incl. blind flange
<b>A</b>	Flange 2" ANSI 1500 lbs incl. blind flange
<b>2</b>	Flange DN 50 PN 160 prepared for shut off valve on side
<b>B</b>	Flange 2" ANSI 1500 lbs prepared for shut off valve on side

**Order codes for magnetic level gauge type ITA-11 and ITA-11.0 (Continuation)**

Code	Description
<b>7.1 Surface float removal flange (bottom side) (only DN50 or 2")</b>	
<b>B</b>	Standard-Surface RF
<b>D</b>	Surface Form E Rz=16
<b>E</b>	Surface RFSF (smooth finished)
<b>F</b>	Surface groove (DIN2512)
<b>G</b>	Surface groove large
<b>H</b>	Surface tongue (DIN2512)
<b>K</b>	Surface tongue-large
<b>L</b>	Surface RTJ (ANSI)
<b>7.2 Bolts &amp; Nuts float removal flange</b>	
<b>1</b>	M24 x 120 mm; mat. CK35/C35 zincd DIN2510; Flange DN 50 PN 160
<b>2</b>	M24 x 120 mm; mat. A2-70 DIN2510; Flange DN 50 PN 160
<b>A</b>	7/8" x 150 mm; mat. A193B7 / A1942H zincd; Flange 2" ANSI 1500 lbs RF/RTJ
<b>B</b>	7/8" x 150 mm; mat. A193B7 / A1942H PTFE coated; Flange 2" ANSI 1500 lbs RF/RTJ
<b>C</b>	7/8" x 150 mm; mat. A193B8 / A1948M stainless steel; Flange 2" ANSI 1500 lbs RF/RTJ
<b>8. Drain plug</b>	
<b>0</b>	without
<b>1</b>	Drain plug G 1/2" with soft iron gasket
<b>2</b>	Drain plug 1/2" NPT
<b>3</b>	Drain plug 3/4" NPT
<b>4</b>	Drain plug 1" NPT
<b>9. Additional drain flange, open</b>	
<b>0</b>	without
<b>1</b>	Drain stud with flange DN 15 PN 160
<b>2</b>	Drain stud with flange DN 25 PN 160
<b>3</b>	Drain stud with flange DN 32 PN 160
<b>4</b>	Drain stud with flange DN 40 PN 160
<b>A</b>	Drain stud with flange 1/2" ANSI 1500 lbs
<b>B</b>	Drain stud with flange 3/4" ANSI 1500 lbs
<b>C</b>	Drain stud with flange 1" ANSI 1500 lbs
<b>D</b>	Drain stud with flange 1 1/4" ANSI 1500 lbs
<b>E</b>	Drain stud with flange 1 1/2" ANSI 1500 lbs
<b>9.1 Drain flange with concentric reducer (X-ray testing)</b>	
<b>0</b>	without
<b>1</b>	DN 15 PN 160
<b>2</b>	DN 25 PN 160
<b>3</b>	DN 32 PN 160
<b>4</b>	DN 40 PN 160
<b>A</b>	1/2" ANSI 1500 lbs
<b>B</b>	3/4" ANSI 1500 lbs
<b>C</b>	1" ANSI 1500 lbs
<b>D</b>	1 1/4" ANSI 1500 lbs
<b>E</b>	1 1/2" ANSI 1500 lbs

**Order codes for magnetic level gauge type ITA-11 and ITA-11.0 (Continuation)**

Code	Description
<b>9.2 Surface open drain flange</b>	
0	without
B	Standard-Surface RF
D	Surface Form E Rz=16
E	Surface RFSF (smooth finished)
F	Surface groove (DIN2512)
G	Surface groove large
H	Surface tongue (DIN2512)
K	Surface tongue-large
L	Surface RTJ (ANSI)
<b>10. Float pipe top end finish</b>	
1	End cap
2	Flange with blind flange DN 50 PN 160
A	Flange with blind flange 2" ANSI 1500 lbs
<b>10.1 Surface float pipe top end finish flange (only DN50 or 2")</b>	
0	without
B	Standard-Surface RF
D	Surface Form E Rz=16
E	Surface RFSF (smooth finished)
F	Surface groove (DIN2512)
G	Surface groove large
H	Surface tongue (DIN2512)
K	Surface tongue-large
L	Surface RTJ (ANSI)
<b>10.2 Bolts &amp; nuts float pipe top end finish flange</b>	
0	without
1	M24 x 120 mm; mat. CK35/C35 zined DIN2510; Flange DN 50 PN 160
2	M24 x 120 mm; mat. A2-70 DIN2510; Flange DN 50 PN 160
A	7/8" x 150 mm; mat. A193B7 / A1942H zined; Flange 2" ANSI 1500 lbs RF/RTJ
B	7/8" x 150 mm; mat. A193B7 / A1942H PTFE coated; Flange 2" ANSI 1500 lbs RF/RTJ
C	7/8" x 150 mm; mat. A193B8 / A1948M stainless steel; Flange 2" ANSI 1500 lbs RF/RTJ
<b>11. Vent plug at top end</b>	
0	without
1	Vent plug G 1/2" with soft iron gasket
2	Vent plug 1/2" NPT
3	Vent plug 3/4" NPT
4	Vent plug 1" NPT
<b>11.1 Vent flange welded to end cap instead of vent plug</b>	
0	without
1	Flange DN 15 PN 160 (socket weld construction to endcap)
2	Flange DN 25 PN 160 (socket weld construction to endcap)
3	Flange DN 32 PN 160 (socket weld construction to endcap)
4	Flange DN 40 PN 160 (socket weld construction to endcap)
A	Flange 1/2" ANSI 1500 lbs (socket weld construction to endcap)
B	Flange 3/4" ANSI 1500 lbs (socket weld construction to endcap)
C	Flange 1" ANSI 1500 lbs (socket weld construction to endcap)
D	Flange 1 1/4" ANSI 1500 lbs (socket weld construction to endcap)
E	Flange 1 1/2" ANSI 1500 lbs (socket weld construction to endcap)

**Order codes for magnetic level gauge type ITA-11 and ITA-11.0 (Continuation)**

Code	Description
<b>11.2 Vent flange with concentric reducer (X-ray testing)</b>	
0	without
1	DN 15 PN 160
2	DN 25 PN 160
3	DN 32 PN 160
4	DN 40 PN 160
A	1/2" ANSI 1500 lbs
B	3/4" ANSI 1500 lbs
C	1" ANSI 1500 lbs
D	1 1/4" ANSI 1500 lbs
E	1 1/2" ANSI 1500 lbs
<b>11.3 Surface vent flange welded to end cap (only DN50 or 2")</b>	
0	without
B	Standard-Surface RF
D	Surface Form E Rz=16
E	Surface RFSF (smooth finished)
F	Surface groove (DIN2512)
G	Surface groove large
H	Surface tongue (DIN2512)
K	Surface tongue-large
L	Surface RTJ (ANSI)
<b>12. Counter flanges</b>	
0	without
1	DN 15 PN 160
2	DN 25 PN 160
3	DN 32 PN 160
4	DN 40 PN 160
5	DN 50 PN 100
A	1/2" ANSI 1500 lbs
B	3/4" ANSI 1500 lbs
C	1" ANSI 1500 lbs
D	1 1/4" ANSI 1500 lbs
E	1 1/2" ANSI 1500 lbs
F	2" 600 lbs
<b>12.1 Surface counter flanges</b>	
0	without
B	Standard-Surface RF
D	Surface Form E Rz=16
E	Surface RFSF (smooth finished)
F	Surface groove (DIN2512)
G	Surface groove large
H	Surface tongue (DIN2512)
K	Surface tongue-large
L	Surface RTJ (ANSI)

**Order codes for magnetic level gauge type ITA-11 and ITA-11.0 (Continuation)**

Code	Description
<b>12.2 Bolts &amp; Nuts counter flanges</b>	
0	without
1	M24 x 120 mm; mat. CK35/C35 zincd DIN2510; Flange DN 50 PN 160
2	M24 x 120 mm; mat. A2-70 DIN2510; Flange DN 50 PN 160
A	7/8" x 150 mm; mat. A193B7 / A1942H zincd; Flange 2" ANSI 1500 lbs RF/RTJ
B	7/8" x 150 mm; mat. A193B7 / A1942H PTFE coated; Flange 2" ANSI 1500 lbs RF/RTJ
C	7/8" x 150 mm; mat. A193B8 / A1948M stainless steel; Flange 2" ANSI 1500 lbs RF/RTJ
<b>13. Additional bracket welded to the float pipe</b>	
0	without
H	Bracket
<b>14. Schwimmer</b>	
F5N2VY	46 x 270; Material: 1.4571; pressure max. 160 bar; min. density of liquid: 0,7736 kg/dm <sup>3</sup> ; type: vented
F2N2SY	42 x 270; Material Titanium; pressure max. 160 bar; min density of liquid: 0,9768 kg/dm <sup>3</sup> ; type: sealed
G2N2SY	42 x 330; Material Titanium; pressure max. 160 bar; min density of liquid: 0,8871 kg/dm <sup>3</sup> ; type: sealed
H2N2SY	42 x 430; Material Titanium; pressure max. 160 bar; min density of liquid: 0,7832 kg/dm <sup>3</sup> ; type: sealed
K2N2SY	42 x 530; Material Titanium; pressure max. 160 bar; min density of liquid: 0,7268 kg/dm <sup>3</sup> ; type: sealed
H2N2SH	42 x 430; Material Titanium; pressure max. 160 bar; min density of liquid: 0,6164 kg/dm <sup>3</sup> ; type: sealed
K2N2SH	42 x 530; Material Titanium; pressure max. 160 bar; min density of liquid: 0,6008 kg/dm <sup>3</sup> ; type: sealed

1	2	3	4	5	6	7	8	9	10	11	12	13	14
ITA-11	L=.....mm												N 2

1	2	3	4	5	6	7	8	9	10	11	12	13	14
ITA-11.0	L=.....mm												N 2



### 3.19.1 ITA-12

Characteristics: PN250 / Float pipe and flange material 1.4404

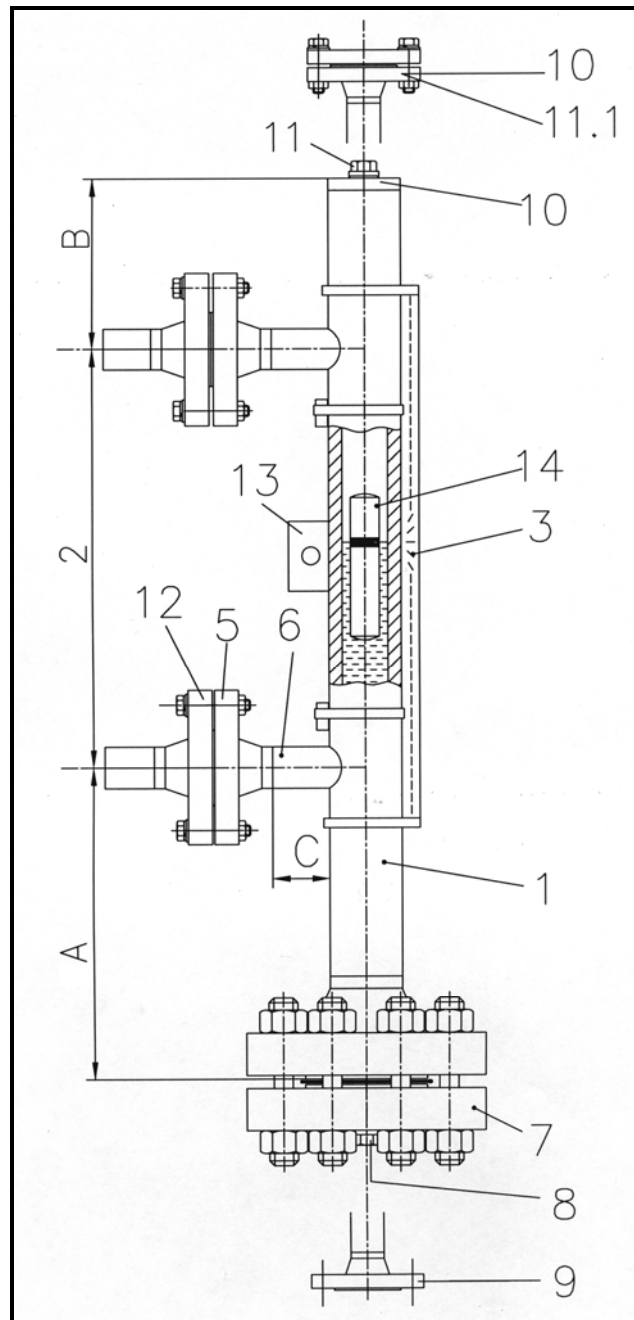

Parts drawing ITA-12

**Key:**

- |   |   |    |                               |
|---|---|----|-------------------------------|
| 1 | Float pipe welded Dimensions 60,3 x 5,54 mm             | 9  | Additional drain flange, open |
| 2 | c to c distance   | 10 | Float pipe top end finish     |
| 3 | Design (indication rail)                                | 11 | Vent plug                     |
| 5 | Process connection side/side                            | 12 | Counter flanges               |
| 6 | Side studs welded with T-pieces for 100 % X-ray testing | 13 | Additional bracket            |
| 7 | Float removal flange                                    | 14 | Float pipe seamless           |
| 8 | Drain plug  | 15 | Float                         |

## Technical specification magnetic level gauge type ITA-12

Principle	:	Communicating tubes with magnetic float
Mounting position	:	vertical
Measuring range	:	<b>max. 5000 mm (one-part)</b> > 5000 mm 2- or multipart
Pipe diameter	:	<b>60,3 x 5,54 mm seamless,</b> <b>welding stud</b> or butt weld construction with T-pieces
Process connection	:	to specify: <b>Flanges DN15-50 (1/2"-2"1500#),</b> <b>Welding or threaded stud</b>
Drain/vent connections	:	<b>Plug 1/2" NPT</b> (for more please see price list)
Pipe material	:	<b>1.4404, 1.4435, 1.4539, Hastelloy C4 (2.4610),</b> Inconel 625 (2.4856), Inconel 825 (2.4858), Titan (3.7035) Other materials also possible (on request)
Flange material	:	same as pipe material
Float material	:	<b>316 Ti, Titanium</b>
Operation temperature	:	-50...+400 °C
Operation pressure	:	max.250 bar
Operation density	:	min. 0,57 kg/dm <sup>3</sup> (vented float) min. 0,828 kg/dm <sup>3</sup> (sealed float)
Bolts & Nuts	:	<b>CS</b> <b>SS</b>
Gasket	:	<b>Spiral wound, 316SS</b> <b>Cam profile, 316SS</b>
Indication rail	:	<b>Makrolon up to 120 °C</b> Aluminium up to 400 °C 1.4301 up to 400 °C
Float types	:	Cylindrical, sealed type (Titanium) Length: - <b>270 mm</b> - 330 mm
Standard dimensions	:	- A = 240* - B = 130** - C = 100

**Base equipment printed in bold letters!**

**\* for densities < 0,7 kg/dm<sup>3</sup> enlarge the scale A**

**\*\* for end cap B=170 mm for WN**

### 3.19.2 ITA-12.0

Characteristics: **PN250 / Float pipe: 1.4404; Flanges: CS**

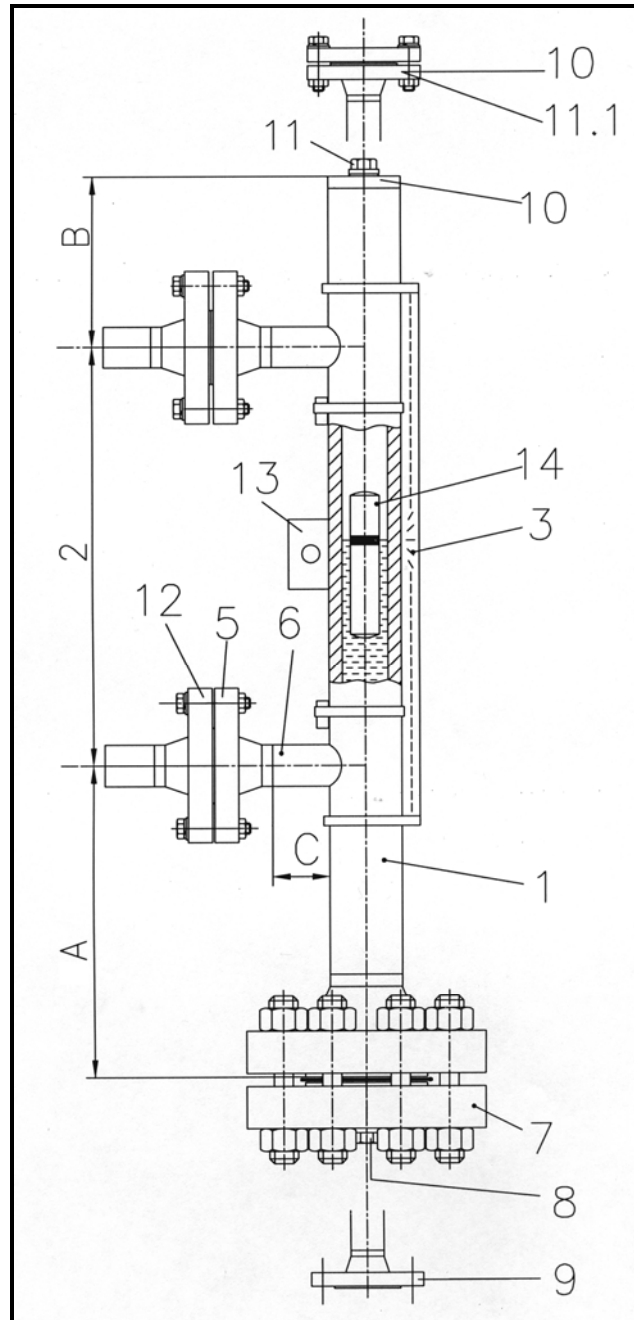

Parts drawing ITA-12.0

**Key:**

- |   |   |    |                               |
|---|---|----|-------------------------------|
| 1 | Float pipe welded Dimensions 60,3 x 5,54 mm             | 9  | Additional drain flange, open |
| 2 | c to c distance   | 10 | Float pipe top end finish     |
| 3 | Design (indication rail)                                | 11 | Vent plug                     |
| 5 | Process connection side/side                            | 12 | Counter flanges               |
| 6 | Side studs welded with T-pieces for 100 % X-ray testing | 13 | Additional bracket            |
| 7 | Float removal flange                                    | 14 | Float pipe seamless           |
| 8 | Drain plug  | 15 | Float                         |

**Technical specification magnetic level gauge type ITA-12.0**

Principle	:	Communicating tubes with magnetic float
Mounting position	:	vertical
Measuring range	:	<b>max. 5000 mm (one-part)</b> > 5000 mm 2- or multipart
Pipe diameter	:	<b>60,3 x 5,54 mm seamless,</b> <b>welding stud</b> or butt weld construction with T-pieces
Process connection	:	to specify: <b>Flanges DN15-50 (1/2"-2"1500#),</b> <b>Welding or threaded stud</b>
Drain/vent connections	:	<b>Plug 1/2" NPT</b> (for more please see price list)
Pipe material	:	<b>1.4404, 1.4435, 1.4539, Hastelloy C4 (2.4610),</b> Inconel 625 (2.4856), Inconel 825 (2.4858), Titan (3.7035) Other materials also possible (on request)
Flange material	:	<b>CS</b>
Float material	:	<b>316 Ti, Titanium</b>
Operation temperature	:	-50...+400 °C
Operation pressure	:	max.250 bar
Operation density	:	min. 0,57 kg/dm <sup>3</sup> (vented float) min. 0,828 kg/dm <sup>3</sup> (sealed float)
Bolts & Nuts	:	<b>CS</b> <b>SS</b>
Gasket	:	<b>Spiral wound, 316SS</b> <b>Cam profile, 316SS</b>
Indication rail	:	<b>Makrolon up to 120 °C</b> Aluminium up to 400 °C 1.4301 up to 400 °C
Float types	:	Cylindrical, sealed type (Titanium) Length: - <b>270 mm</b> - 330 mm
Standard dimensions	:	- A = 240* - B = 130** - C = 100

**Base equipment printed in bold letters!**

**\* for densities < 0,7 kg/dm<sup>3</sup> enlarge the scale A**

**\*\* for end cap B=170 mm for WN**

<b>Order codes for magnetic level gauge type ITA-12 and ITA-12.0</b>
--

Code	Description
<b>ITA-12 ITA-12.0</b>	<b>1. Float pipe seamless Dimensions 60,3 x 5,54 mm</b>
	<b>2. C to C distance</b>
<b>L</b>	C to C distance in mm
	<b>3. Design</b>
<b>0</b>	without indication rail
<b>1</b>	Indication rail material: Makrolon max. 120 °C
<b>2</b>	Indication rail material: Aluminium max. 400 °C
<b>3</b>	Indication rail material: 1.4401 max. 400 °C
	<b>4. C to C distance &lt; 5000 mm</b>
<b>A</b>	< 5000 mm - without flange connection; DN 50 PN 250
<b>B</b>	> 5000 mm - with flange connection; DN 50 PN 250
	<b>5. Process connections side/side</b>
<b>Y</b>	Welding connection (please specify)
<b>Z</b>	Threaded stud (please specify)
<b>0</b>	Flanges DN 15 PN 250
<b>1</b>	Flanges DN 25 PN 250
<b>2</b>	Flanges DN 32 PN 250
<b>3</b>	Flanges DN 40 PN 250
<b>4</b>	Flanges DN 50 PN 250
<b>A</b>	Flanges 1/2" ANSI 1500 lbs
<b>B</b>	Flanges 3/4" ANSI 1500 lbs
<b>C</b>	Flanges 1" ANSI 1500 lbs
<b>D</b>	Flanges 1 1/4" ANSI 1500 lbs
<b>E</b>	Flanges 1 1/2" ANSI 1500 lbs
<b>F</b>	Flanges 2" ANSI 1500 lbs
	<b>5.1 Surface side flanges</b>
<b>0</b>	without
<b>B</b>	Standard-Surface RF
<b>D</b>	Surface Form E Rz=16
<b>E</b>	Surface RFSF (smooth finished)
<b>G</b>	Surface groove large
<b>K</b>	Surface tongue-large
<b>L</b>	Surface RTJ (ANSI)
	<b>6. Side studs welded with T-pieces for 100 % X-ray testing</b>
<b>0</b>	without
<b>T</b>	T-pieces
	<b>7. Float removal flange (bottom side)</b>
<b>1</b>	Flange DN 50 PN 250 incl. blind flange
<b>A</b>	Flange 2" ANSI 1500 lbs incl. blind flange
<b>2</b>	Flange DN 50 PN 250 prepared for shut off valve on side
<b>B</b>	Flange 2" ANSI 1500 lbs prepared for shut off valve on side

**Order codes for magnetic level gauge type ITA-12 and ITA-12.0 (Continuation)**

Code	Description
<b>7.1 Surface float removal flange (bottom side)</b>	
<b>B</b>	Standard-Surface RF
<b>D</b>	Surface Form E Rz=16
<b>E</b>	Surface RFSF (smooth finished)
<b>G</b>	Surface groove large
<b>K</b>	Surface tongue-large
<b>L</b>	Surface RTJ (ANSI)
<b>7.2 Bolts &amp; Nuts float removal flange</b>	
<b>1</b>	M24 x 140 mm; mat. CK35/C35 zincd DIN2510; Flange DN 50 PN 250
<b>2</b>	M24 x 140 mm; mat. A2-70 DIN2510; Flange DN 50 PN 250
<b>A</b>	7/8" x 150 mm; mat. A193B7 / A1942H zincd; Flange 2" ANSI 1500 lbs RF/RTJ
<b>B</b>	7/8" x 150 mm; mat. A193B7 / A1942H PTFE coated; Flange 2" ANSI 1500 lbs RF/RTJ
<b>C</b>	7/8" x 150 mm; mat. A193B8 / A1948M stainless steel; Flange 2" ANSI 1500 lbs RF/RTJ
<b>8. Drain plug</b>	
<b>0</b>	without
<b>1</b>	Drain plug G 1/2" with soft iron gasket
<b>2</b>	Drain plug 1/2" NPT
<b>3</b>	Drain plug 3/4" NPT
<b>4</b>	Drain plug 1" NPT
<b>9. Additional drain flange, open</b>	
<b>0</b>	without
<b>1</b>	Drain-stud with flange DN 15 PN 250
<b>2</b>	Drain-stud with flange DN 25 PN 250
<b>3</b>	Drain-stud with flange DN 32 PN 250
<b>4</b>	Drain-stud with flange DN 40 PN 250
<b>A</b>	Drain-stud with flange 1/2" ANSI 1500 lbs
<b>B</b>	Drain-stud with flange 3/4" ANSI 1500 lbs
<b>C</b>	Drain-stud with flange 1" ANSI 1500 lbs
<b>D</b>	Drain-stud with flange 1 1/4" ANSI 1500 lbs
<b>E</b>	Drain-stud with flange 1 1/2" ANSI 1500 lbs
<b>9.1 Drain flange with concentric reducer (X-ray testing)</b>	
<b>0</b>	without
<b>1</b>	DN 15 PN 250
<b>2</b>	DN 25 PN 250
<b>3</b>	DN 32 PN 250
<b>4</b>	DN 40 PN 250
<b>A</b>	1/2" ANSI 1500 lbs
<b>B</b>	3/4" ANSI 1500 lbs
<b>C</b>	1" ANSI 1500 lbs
<b>D</b>	1 1/4" ANSI 1500 lbs
<b>E</b>	1 1/2" ANSI 1500 lbs

**Order codes for magnetic level gauge type ITA-12 and ITA-12.0 (Continuation)**

Code	Description
<b>9.2 Surface open drain flange</b>	
0	without
B	Standard-Surface RF
D	Surface Form E Rz=16
E	Surface RFSF (smooth finished)
G	Surface groove large
K	Surface tongue-large
L	Surface RTJ (ANSI)
<b>10. Float pipe top end finish</b>	
1	End cap
2	Flange with blind flange DN 50 PN 250
A	Flange with blind flange 2" ANSI 1500 lbs
<b>10.1 Surface float pipe top end finish flange (only DN50 or 2")</b>	
0	without
B	Standard-Surface RF
D	Surface Form E Rz=16
E	Surface RFSF (smooth finished)
G	Surface groove large
K	Surface tongue-large
L	Surface RTJ (ANSI)
<b>10.2 Bolts &amp; nuts float pipe top end finish flange</b>	
0	without
1	M24 x 140 mm; mat. CK35/C35 zincated DIN2510; Flange DN 50 PN 250
2	M24 x 140 mm; mat. A2-70 DIN2510; Flange DN 50 PN 250
A	7/8" x 150 mm; mat. A193B7 / A1942H zincated; Flange 2" ANSI 1500 lbs RF/RTJ
B	7/8" x 150 mm; mat. A193B7 / A1942H PTFE coated; Flange 2" ANSI 1500 lbs RF/RTJ
C	7/8" x 150 mm; mat. A193B8 / A1948M stainless steel; Flange 2" ANSI 1500 lbs RF/RTJ
<b>11. Vent plug at top end</b>	
0	without
1	Vent plug G1/2" with soft iron gasket
2	Vent plug 1/2" NPT
3	Vent plug 3/4" NPT
4	Vent plug 1" NPT
<b>11.1 Vent flange welded to end cap instead of vent plug</b>	
0	without
1	Flange DN 15 PN 250 (socket weld construction to endcap)
2	Flange DN 25 PN 250 (socket weld construction to endcap)
3	Flange DN 32 PN 250 (socket weld construction to endcap)
4	Flange DN 40 PN 250 (socket weld construction to endcap)
A	Flange 1/2" ANSI 1500 lbs (socket weld construction to endcap)
B	Flange 3/4" ANSI 1500 lbs (socket weld construction to endcap)
C	Flange 1" ANSI 1500 lbs (socket weld construction to endcap)
D	Flange 1 1/4" ANSI 1500 lbs (socket weld construction to endcap)
E	Flange 1 1/2" ANSI 1500 lbs (socket weld construction to endcap)

**Order codes for magnetic level gauge type ITA-12 and ITA-12.0 (Continuation)**

Code	Description
<b>11.2 Vent flange with concentric reducer (X-ray testing)</b>	
0	without
1	DN 15 PN 250
2	DN 25 PN 250
3	DN 32 PN 250
4	DN 40 PN 250
A	1/2" ANSI 1500 lbs
B	3/4" ANSI 1500 lbs
C	1" ANSI 1500 lbs
D	1 1/4" ANSI 1500 lbs
E	1 1/2" ANSI 1500 lbs
<b>11.3 Surface vent flange welded to end cap (only DN50 or 2")</b>	
0	without
B	Standard-Surface RF
D	Surface Form E Rz=16
E	Surface RFSF (smooth finished)
G	Surface groove large
K	Surface tongue-large
L	Surface RTJ (ANSI)
<b>12. Counter flanges</b>	
0	without
1	DN 15 PN 250
2	DN 25 PN 250
3	DN 32 PN 250
4	DN 40 PN 250
5	DN 50 PN 250
A	1/2" ANSI 1500 lbs
B	3/4" ANSI 1500 lbs
C	1" ANSI 1500 lbs
D	1 1/4" ANSI 1500 lbs
E	1 1/2" ANSI 1500 lbs
F	2" ANSI 1500 lbs
<b>12.1 Surface counter flanges</b>	
0	without
B	Standard-Surface RF
D	Surface Form E Rz=16
E	Surface RFSF (smooth finished)
G	Surface groove large
K	Surface tongue-large
L	Surface RTJ (ANSI)
<b>12.2 Bolts &amp; Nuts counter flanges</b>	
0	without
1	M24 x 140 mm; mat. CK35/C35 zincd DIN2510; Flange DN 50 PN 250
2	M24 x 140 mm; mat. A2-70 DIN2510; Flange DN 50 PN 250
A	7/8" x 150 mm; mat. A193B7 / A1942H zincd; Flange 2" ANSI 1500 lbs RF/RTJ
B	7/8" x 150 mm; mat. A193B7 / A1942H PTFE coated; Flange 2" ANSI 1500 lbs RF/RTJ
C	7/8" x 150 mm; mat. A193B8 / A1948M stainless steel; Flange 2" ANSI 1500 lbs RF/RTJ



**Order codes for magnetic level gauge type ITA-12 and ITA-12.0 (Continuation)**

Code	Description
<b>13. Additional bracket welded to the float pipe</b>	
<b>0</b>	without
<b>H</b>	Bracket
<b>14. Float</b>	
<b>F5R1VY</b>	46 x 270; material: 1.4571; pressure max. 250 bar min. density of liquid: 0,7736 kg/dm <sup>3</sup> ; type: vented
<b>F4R2VY</b>	45 x 270; material: Titanium; pressure max. 250 bar min density of liquid: 0,5774 kg/dm <sup>3</sup> ; type: vented
<b>F2R2SY</b>	42 x 270; material: Titanium; pressure max. 250 bar min density of liquid: 1,0396 kg/dm <sup>3</sup> ; type: sealed
<b>G2R2SY</b>	42 x 330; material: Titanium; pressure max. 250 bar min density of liquid: 0,925 kg/dm <sup>3</sup> ; type: sealed
<b>H2R2SY</b>	42 x 430; material: Titanium; pressure max. 250 bar min density of liquid: 0,8304 kg/dm <sup>3</sup> ; type: sealed
<b>F1R2SH</b>	38 x 270; material: Titanium; pressure max. 250 bar min density of liquid: 0,8944 kg/dm <sup>3</sup> ; type: sealed
<b>G1R2SH</b>	38 x 330; material: Titanium; pressure max. 250 bar min density of liquid: 0,828 kg/dm <sup>3</sup> ; type: sealed

1	2	3	4	5	6	7	8	9	10	11	12	13	14
ITA-12	L=.....mm												R

1	2	3	4	5	6	7	8	9	10	11	12	13	14
ITA-12.0	L=.....mm												R

**3.20.1 ITA-13**

Characteristics: PN320 / Float pipe and flange material 1.4404

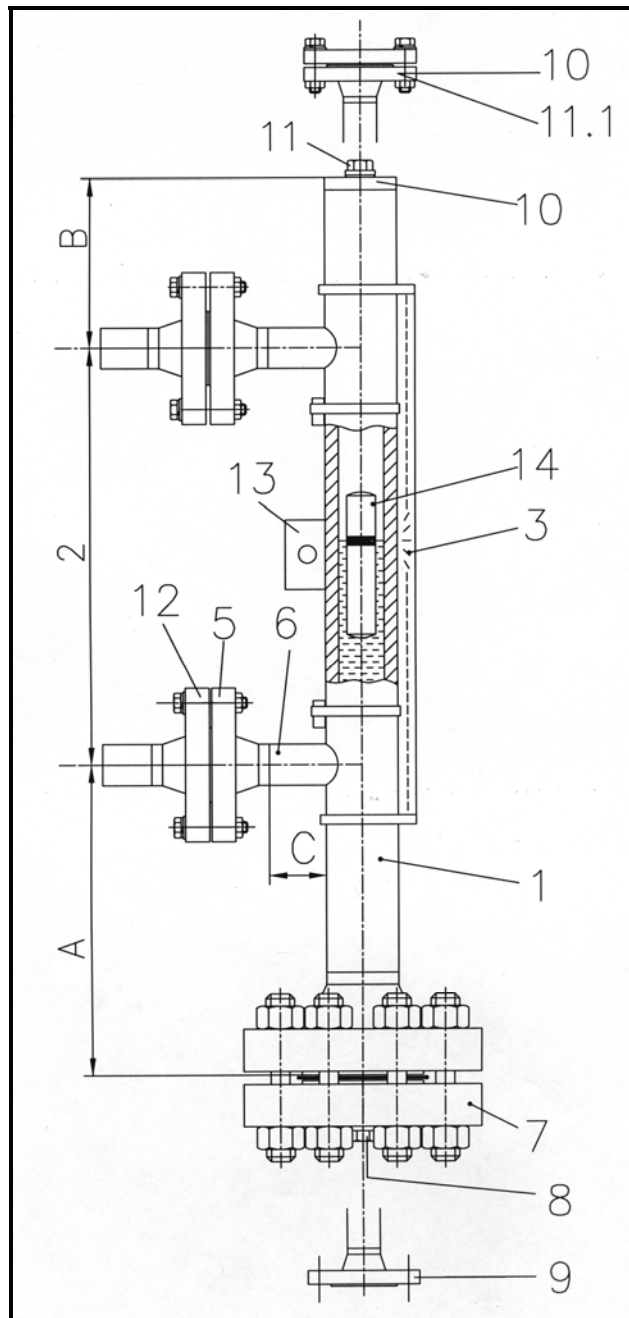

Parts drawing ITA-13

**Key:**

- |   |   |    |                               |
|---|---|----|-------------------------------|
| 1 | Float pipe welded Dimensions 60,3 x 8,7 mm              | 9  | Additional drain flange, open |
| 2 | c to c distance   | 10 | Float pipe top end finish     |
| 3 | Design (indication rail)                                | 11 | Vent plug                     |
| 5 | Process connection side/side                            | 12 | Counter flanges               |
| 6 | Side studs welded with T-pieces for 100 % X-ray testing | 13 | Additional bracket            |
| 7 | Float removal flange                                    | 14 | Float pipe seamless           |
| 8 | Drain plug  | 15 | Float                         |

### Technical specifications magnetic level gauge type ITA-13

Principle	:	Communicating tubes with magnetic float
Mounting position	:	vertical
Measuring range	:	<b>max. 5000 mm (one-part)</b> > 5000 mm 2- or multipart
Pipe diameter	:	<b>60,3 x 8,7 mm seamless,</b> <b>welding stud</b> or butt weld construction with T-pieces
Process connection	:	to specify: <b>Flanges DN15-50 (1/2"-2"2500#),</b> <b>Welding or threaded stud</b>
Drain/vent connections	:	<b>Plug 1/2" NPT</b> (for more please see price list)
Pipe material	:	<b>1.4404</b> , 1.4435, 1.4539, Hastelloy C4 (2.4610), Inconel 625 (2.4856), Inconel 825 (2.4858), Titan (3.7035) Other materials also possible (on request)
Flange material	:	same as pipe material
Float material	:	<b>Titanium</b>
Operation temperature	:	-50...+400 °C
Operation pressure	:	max.320 bar
Operation density	:	min. 0,5032 kg/dm <sup>3</sup> (vented float) min. 0,7582 kg/dm <sup>3</sup> (sealed float)
Bolts & Nuts	:	<b>CS</b> SS
Gasket	:	<b>Spiral wound, 316SS</b> <b>Cam profile, 316SS</b>
Indication rail	:	<b>Makrolon up to 120 °C</b> Aluminium up to 400 °C 1.4301 up to 400 °C
Float types	:	Cylindrical, sealed type (Titanium) Length: - <b>270 mm</b> - 330 mm - 430 mm
Standard dimensions	:	- A = 240* - B = 130** - C = 100

**Base equipment printed in bold letters!**

**\*depending on density enlarge the scale A**

**\*\* for end cap B=170 mm for WN**

**3.20.2 ITA-13.0**

Characteristics: **PN320 / Float pipe: 1.4404; Flanges: CS**

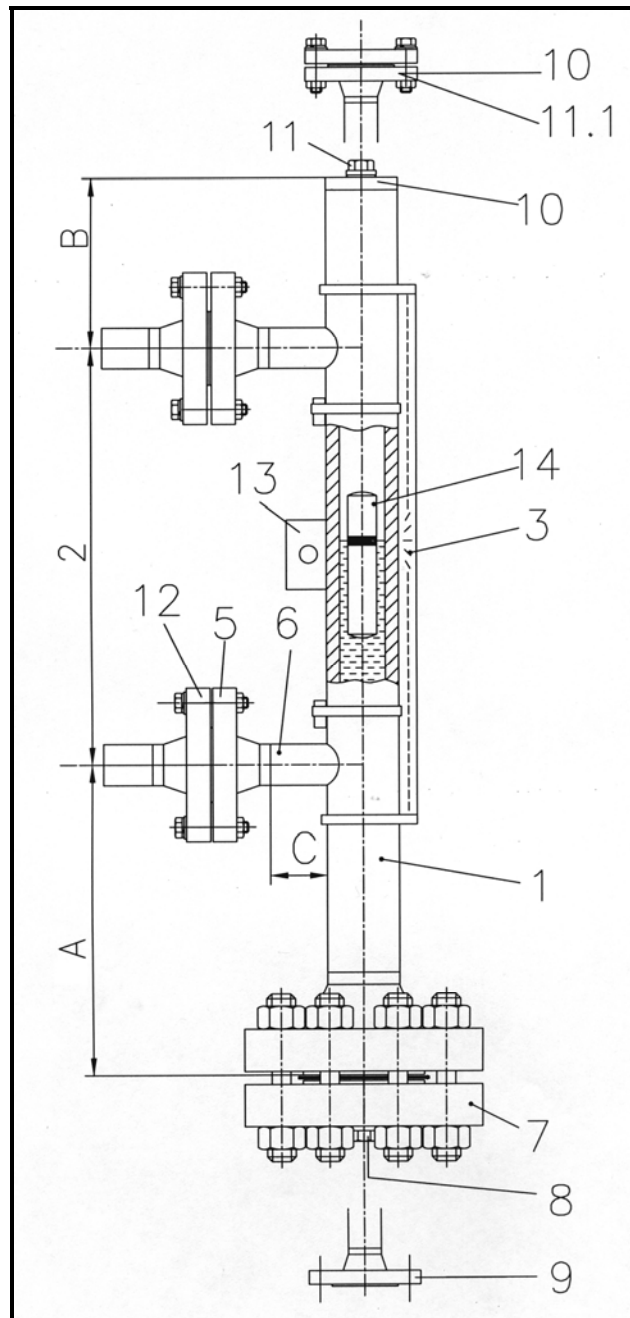

Parts drawing ITA-13.0

**Key:**

- |   |   |    |                               |
|---|---|----|-------------------------------|
| 1 | Float pipe welded Dimensions 60,3 x 8,7 mm              | 9  | Additional drain flange, open |
| 2 | c to c distance   | 10 | Float pipe top end finish     |
| 3 | Design (indication rail)                                | 11 | Vent plug                     |
| 5 | Process connection side/side                            | 12 | Counter flanges               |
| 6 | Side studs welded with T-pieces for 100 % X-ray testing | 13 | Additional bracket            |
| 7 | Float removal flange                                    | 14 | Float pipe seamless           |
| 8 | Drain plug  | 15 | Float                         |

### Technical specifications magnetic level gauge type ITA-13.0

Principle	:	Communicating tubes with magnetic float
Mounting position	:	vertical
Measuring range	:	<b>max. 5000 mm (one-part)</b> > 5000 mm 2- or multipart
Pipe diameter	:	<b>60,3 x 8,7 mm seamless,</b> <b>welding stud</b> or butt weld construction with T-pieces
Process connection	:	to specify: <b>Flanges DN15-50 (1/2"-2"2500#),</b> <b>Welding or threaded stud</b>
Drain/vent connections	:	<b>Plug 1/2" NPT</b> (for more please see price list)
Pipe material	:	<b>1.4404</b> , 1.4435, 1.4539, Hastelloy C4 (2.4610), Inconel 625 (2.4856), Inconel 825 (2.4858), Titan (3.7035) Other materials also possible (on request)
Flange material	:	<b>CS</b>
Float material	:	<b>Titanium</b>
Operation temperature	:	-50...+400 °C
Operation pressure	:	max.320 bar
Operation density	:	min. 0,5032 kg/dm <sup>3</sup> (vented float) min. 0,7582 kg/dm <sup>3</sup> (sealed float)
Bolts & Nuts	:	<b>CS</b> <b>SS</b>
Gasket	:	<b>Spiral wound, 316SS</b> <b>Cam profile, 316SS</b>
Indication rail	:	<b>Makrolon up to 120 °C</b> Aluminium up to 400 °C 1.4301 up to 400 °C
Float types	:	Cylindrical, sealed type (Titanium) Length: - <b>270 mm</b> - 330 mm - 430 mm
Standard dimensions	:	- A = 240* - B = 130** - C = 100

**Base equipment printed in bold letters!**

**\*depending on density enlarge the scale A**

**\*\* for end cap B=170 mm for WN**

**Order codes for magnetic level gauge type ITA-13 and ITA-13.0**

Code	Description
<b>ITA-13 ITA-13.0</b>	<b>1. Float pipe seamless Dimensions 60,3 x 8,7 mm</b>
	<b>2. C to C distance</b>
<b>L</b>	C to C distance in mm
	<b>3. Design</b>
<b>0</b>	without indication rail
<b>1</b>	Indication rail material: Makrolon max. 120 °C
<b>2</b>	Indication rail material: Aluminium max. 400 °C
<b>3</b>	Indication rail material: 1.4401 max. 400 °C
	<b>4. C to C distance &lt; 5000 mm</b>
<b>A</b>	< 5000 mm - without flange connection; DN 50 PN 320
<b>B</b>	> 5000 mm - with flange connection; DN 50 PN 320
	<b>5. Process connections side/side</b>
<b>Y</b>	Welding connections (please specify)
<b>Z</b>	Threaded connections (please specify)
<b>0</b>	Flanges DN 15 PN 320
<b>1</b>	Flanges DN 25 PN 320
<b>2</b>	Flanges DN 32 PN 320
<b>3</b>	Flanges DN 40 PN 320
<b>4</b>	Flanges DN 50 PN 320
<b>A</b>	Flanges 1/2" ANSI 2500 lbs
<b>B</b>	Flanges 3/4" ANSI 2500 lbs
<b>C</b>	Flanges 1" ANSI 2500 lbs
<b>D</b>	Flanges 1 1/4" ANSI 2500 lbs
<b>E</b>	Flanges 1 1/2" ANSI 2500 lbs
<b>F</b>	Flanges 2" ANSI 2500 lbs
	<b>5.1 Surface side flanges</b>
<b>0</b>	without
<b>C</b>	Standard-Surface RF
<b>F</b>	Surface Form E Rz=16
<b>G</b>	Surface RFSF (smooth finished)
<b>H</b>	Surface groove large
<b>I</b>	Surface tongue-large
<b>J</b>	Surface RTJ (ANSI)
	<b>6. Side studs welded with T-pieces for 100 % X-ray testing</b>
<b>0</b>	without
<b>T</b>	T-pieces
	<b>7. Float removal flange (bottom side)</b>
<b>1</b>	Flange DN 50 PN 320 incl. blind flange
<b>A</b>	Flange 2" ANSI 2500 lbs incl. blind flange
<b>2</b>	Flange DN 50 PN 320 prepared for shut off valve on side
<b>B</b>	Flange 2" ANSI 2500 lbs prepared for shut off valve on side

<b>Order codes for magnetic level gauge type ITA-13 and ITA-13.0 (Continuation)</b>
---

Code	Description
<b>7.1 Surface float removal flange (bottom side)</b>	
<b>C</b>	Standard-Surface RF
<b>F</b>	Surface Form E Rz=16
<b>G</b>	Surface RFSF (smooth finished)
<b>H</b>	Surface groove large
<b>I</b>	Surface tongue-large
<b>J</b>	Surface RTJ (ANSI)
<b>7.2 Bolts &amp; Nuts float removal flange</b>	
<b>1</b>	M24 x 150 mm; mat. CK35/C35 zincd DIN2510; Flange DN 50 PN 320
<b>2</b>	M24 x 150 mm; mat. A2-70 DIN2510; Flange DN 50 PN 320
<b>A</b>	1" x 190 mm; mat. A193B7 / A1942H zincd; Flange 2" ANSI 2500 lbs RF
<b>B</b>	1" x 190 mm; mat. A193B7 / A1942H PTFE coated; Flange 2" ANSI 2500 lbs RF
<b>C</b>	1" x 190 mm; mat. A193B8 / A1948M stainless steel; Flange 2" ANSI 2500 lbs RF
<b>8. Drain plug</b>	
<b>0</b>	without
<b>1</b>	Drain plug G 1/2" with soft iron gasket
<b>2</b>	Drain plug 1/2" NPT
<b>3</b>	Drain plug 3/4" NPT
<b>4</b>	Drain plug 1" NPT
<b>9. Additional drain flange, open</b>	
<b>0</b>	without
<b>1</b>	Drain stud with flange DN 15 PN 320
<b>2</b>	Drain stud with flange DN 25 PN 320
<b>3</b>	Drain stud with flange DN 32 PN 320
<b>4</b>	Drain stud with flange DN 40 PN 320
<b>A</b>	Drain stud with flange 1/2" ANSI 2500 lbs
<b>B</b>	Drain stud with flange 3/4" ANSI 2500 lbs
<b>C</b>	Drain stud with flange 1" ANSI 2500 lbs
<b>D</b>	Drain stud with flange 1 1/4" ANSI 2500 lbs
<b>E</b>	Drain stud with flange 1 1/2" ANSI 2500 lbs
<b>9.1 Drain flange with concentric reducer (X-ray testing)</b>	
<b>0</b>	without
<b>1</b>	DN 15 PN 320
<b>2</b>	DN 25 PN 320
<b>3</b>	DN 32 PN 320
<b>4</b>	DN 40 PN 320
<b>A</b>	1/2" ANSI 2500 lbs
<b>B</b>	3/4" ANSI 2500 lbs
<b>C</b>	1" ANSI 2500 lbs
<b>D</b>	1 1/4" ANSI 2500 lbs
<b>E</b>	1 1/2" ANSI 2500 lbs

**Order codes for magnetic level gauge type ITA-13 and ITA-13.0 (Continuation)**

Code	Description
<b>9.2 Surface open drain flange</b>	
0	without
C	Standard-Surface RF
F	Surface Form E Rz=16
G	Surface RFSF (smooth finished)
H	Surface groove large
I	Surface tongue-large
J	Surface RTJ (ANSI)
<b>10. Float pipe top end finish</b>	
0	End cap
1	Flange with blind flange DN 50 PN 320
A	Flange with blind flange 2" ANSI 2500 lbs
<b>10.1 Surface float pipe top end finish flange (only DN50 or 2")</b>	
0	without
C	Standard-Surface RF
F	Surface Form E Rz=16
G	Surface RFSF (smooth finished)
H	Surface groove large
I	Surface tongue-large
J	Surface RTJ (ANSI)
<b>10.2 Bolts &amp; nuts float pipe top end finish flange</b>	
0	without
1	M24 x 150 mm; mat. CK35/C35 zincd DIN2510; Flange DN 50 PN 320
2	M24 x 150 mm; mat. A2-70 DIN2510; Flange DN 50 PN 320
A	1" x 190 mm; mat. A193B7 / A1942H zincd; Flange 2" ANSI 2500 lbs RF
B	1" x 190 mm; mat. A193B7 / A1942H PTFE coated; Flange 2" ANSI 2500 lbs RF
C	1" x 190 mm; mat. A193B8 / A1948M stainless steel; Flange 2" ANSI 2500 lbs RF
<b>11. Vent plug at top end</b>	
0	without
1	Vent plug G1/2" with soft iron gasket
2	Vent plug 1/2" NPT
3	Vent plug 3/4" NPT
4	Vent plug 1" NPT
<b>11.1 Vent flange welded to end cap instead of vent plug</b>	
0	without
1	Flange DN 15 PN 320 (socket weld construction to endcap)
2	Flange DN 25 PN 320 (socket weld construction to endcap)
3	Flange DN 32 PN 320 (socket weld construction to endcap)
4	Flange DN 40 PN 320 (socket weld construction to endcap)
A	Flange 1/2" ANSI 2500 lbs (socket weld construction to endcap)
B	Flange 3/4" ANSI 2500 lbs (socket weld construction to endcap)
C	Flange 1" ANSI 2500 lbs (socket weld construction to endcap)
D	Flange 1 1/4" ANSI 2500 lbs (socket weld construction to endcap)
E	Flange 1 1/2" ANSI 2500 lbs (socket weld construction to endcap)



**Order codes for magnetic level gauge type ITA-13 and ITA-13.0 (Continuation)**

Code	Description
<b>11.2 Vent flange with concentric reducer (X-ray testing)</b>	
0	without
1	DN 15 PN 320
2	DN 25 PN 320
3	DN 32 PN 320
4	DN 40 PN 320
A	1/2" ANSI 2500 lbs
B	3/4" ANSI 2500 lbs
C	1" ANSI 2500 lbs
D	1 1/4" ANSI 2500 lbs
E	1 1/2" ANSI 2500 lbs
<b>11.3 Surface vent flange welded to end cap (only DN50 or 2")</b>	
0	without
C	Standard-Surface RF
F	Surface Form E Rz=16
G	Surface RFSF (smooth finished)
H	Surface groove large
I	Surface tongue-large
J	Surface RTJ (ANSI)
<b>12. Counter flanges</b>	
0	without
1	DN 15 PN 320
2	DN 25 PN 320
3	DN 32 PN 320
4	DN 40 PN 320
5	DN 50 PN 320
A	1/2" ANSI 2500 lbs
B	3/4" ANSI 2500 lbs
C	1" ANSI 2500 lbs
D	1 1/4" ANSI 2500 lbs
E	1 1/2" ANSI 2500 lbs
F	2" ANSI 2500 lbs
<b>12.1 Surface counter flanges</b>	
0	without
C	Standard-Surface RF
F	Surface Form E Rz=16
G	Surface RFSF (smooth finished)
H	Surface groove large
I	Surface tongue-large
J	Surface RTJ (ANSI)
<b>12.2 Bolts &amp; Nuts counter flanges</b>	
0	without
1	M24 x 150 mm; mat. CK35/C35 zincd DIN2510; Flange DN 50 PN 320
2	M24 x 150 mm; mat. A2-70 DIN2510; Flange DN 50 PN 320
A	1" x 190 mm; mat. A193B7 / A1942H zincd; Flange 2" ANSI 2500 lbs RF
B	1" x 190 mm; mat. A193B7 / A1942H PTFE coated; Flange 2" ANSI 2500 lbs RF
C	1" x 190 mm; mat. A193B8 / A1948M stainless steel; Flange 2" ANSI 2500 lbs RF

**Order codes for magnetic level gauge type ITA-13 and ITA-13.0 (Continuation)**

Code	Description
<b>13. Additional bracket welded to the float pipe</b>	
<b>0</b>	without
<b>H</b>	Bracket
Code	Description
<b>14. Float</b>	
<b>G1W1VY</b>	38 x 330 material: 1.4571 pressure max. 320 bar min. density of liquid: 0,7269 kg/dm <sup>3</sup> vented
<b>F1W2SY</b>	38 x 270 material: Titanium pressure max. 250 bar min. density of liquid: 0,888 kg/dm <sup>3</sup> sealed
<b>G1W2VY</b>	38 x 330 material: Titanium pressure max. 320 bar min. density of liquid: 0,5032 kg/dm <sup>3</sup> vented
<b>F1W2SH</b>	38 x 270 material: Titanium pressure max. 200 bar min. density of liquid: 0,9757 kg/dm <sup>3</sup> sealed
<b>H1W2SH</b>	38 x 430 material: Titanium pressure max. 250 bar min. density of liquid: 0,7582 kg/dm <sup>3</sup> sealed

1	2	3	4	5	6	7	8	9	10	11	12	13	14
ITA-13	L=.....mm												1 W

1	2	3	4	5	6	7	8	9	10	11	12	13	14
ITA-13.0	L=.....mm												1 W

**4. Equipment**

**4.1 ITA-3 Cryo; ITA-3.0 Cryo**

If Armaflex is used for insulation (t=9 mm) the material for the indication rail will be aluminium. As standard for the level gauge in Cryo-design we use a float chamber  $\varnothing 60,3 \times 2$  mm with a float from titanium ( $\varnothing 50,8 \times 240$  mm length) down to a liquid density of  $0,6 \text{ kg/dm}^3$ .

For temperatures below  $-40^\circ\text{C}$  the Armaflex insulation is double ply, the upper layer only up to the indication rail.

The customer should also insulate the process flanges.

For vaporizing media (for example ammonia) we recommend to use floats with 4 distance sleeves (In this case the floats are smaller than standard floats). This construction prevents catapulting the float upwards (this would cause switch failures) if gas evolution appears.

For temperatures down to  $-20^\circ\text{C}$  we are using a float chamber  $\varnothing 60,3 \times 2$  mm and a titanium float  $\varnothing 45 \times 400$  mm, for temperatures below  $-20^\circ\text{C}$  we are using a float chamber  $\varnothing 64 \times 2$  mm and a titanium float  $\varnothing 50,8 \times 500$  mm.

In every case we use flanges DN50 as drain connections (weld neck and blind flanges with groove and tongue). When the dimension of the float chamber is  $\varnothing 64 \times 2$  mm, it is necessary to modify the weld neck flange.

On request by the customer we make use of small hole (throttling part) to transmit the liquid level to the float chamber. It stabilizes the float movement (damping).

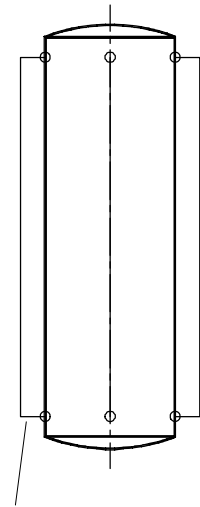

distance sleeve

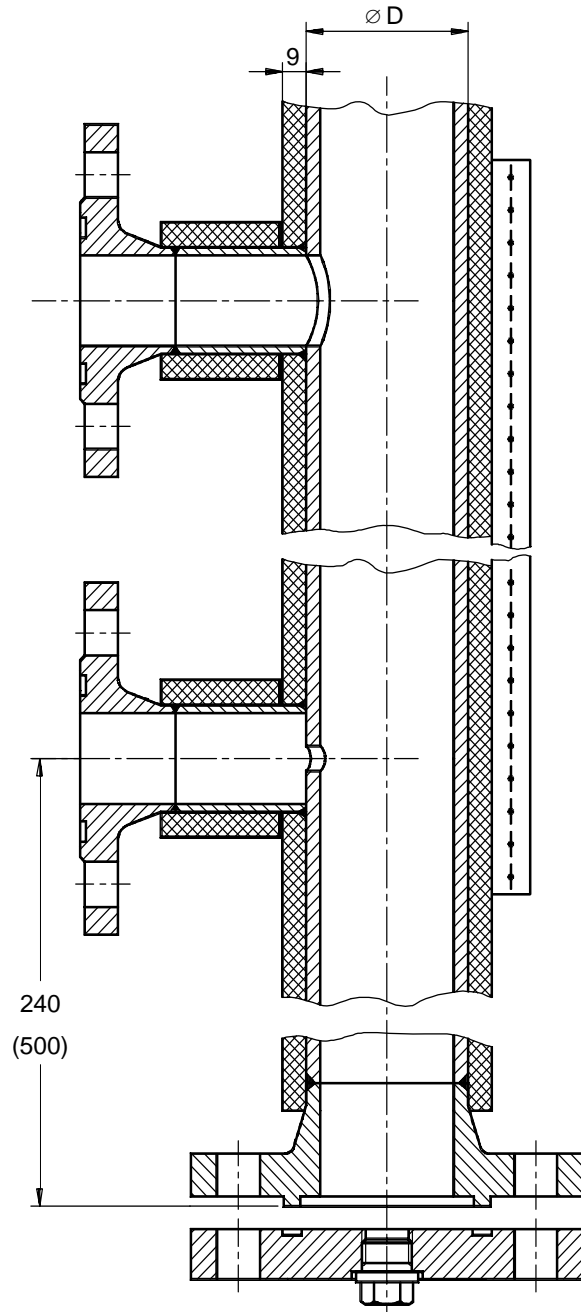

throttling part dependence on the temperature:  
 $\varnothing 4 \text{ mm}$  for  $T \geq -20^\circ\text{C}$   
 $\varnothing 2 \text{ mm}$  for  $T < -20^\circ\text{C}$

**4.2 Armaflex®-insulation**

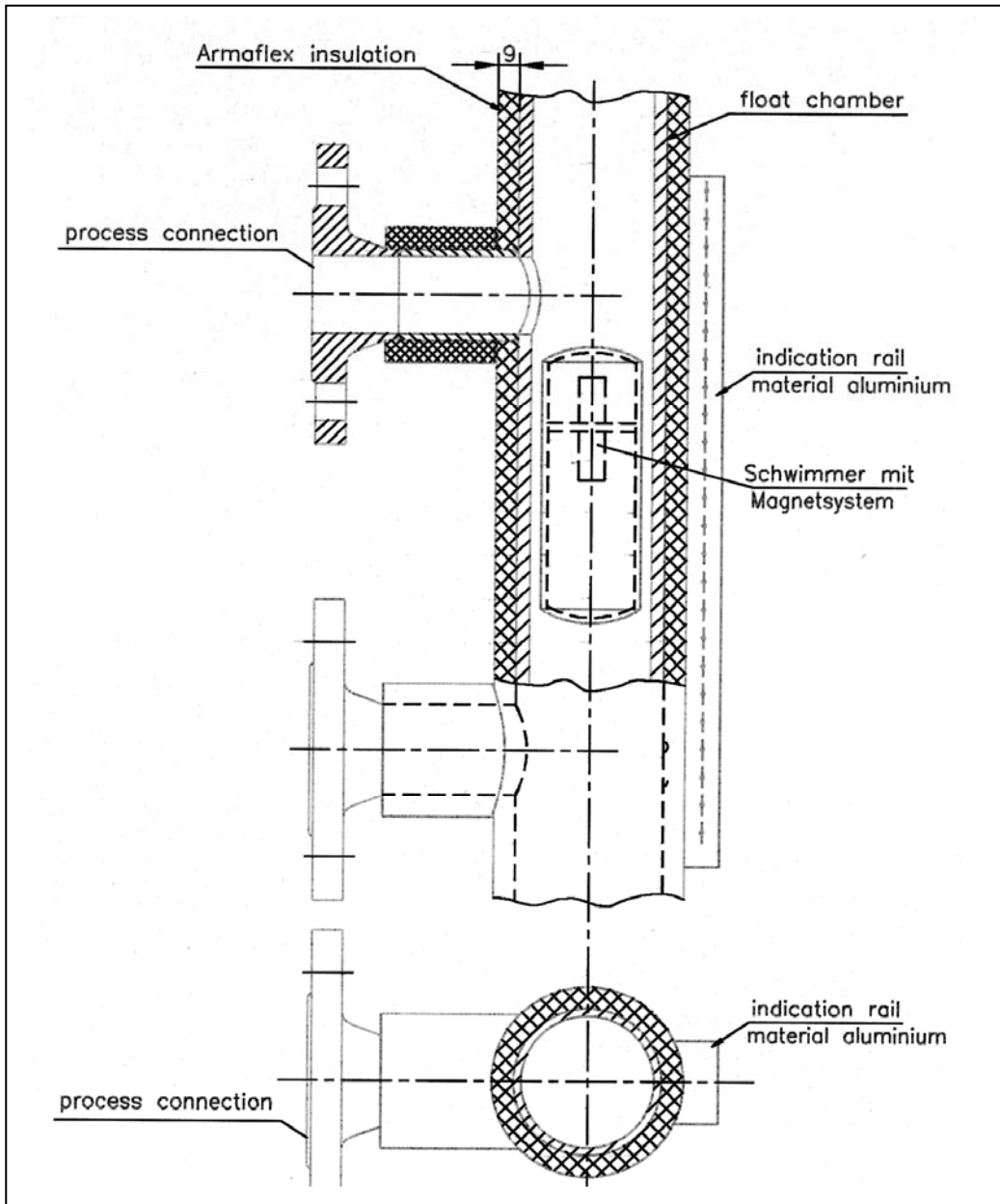

### 4.3 Heat insulation

#### Isolation and sealing material

made of e-glassyarns

#### Technical data:

Composition in %	: 53 % SiO <sub>2</sub> , 16 % CaO, 13 % Al <sub>2</sub> O <sub>3</sub> , 7 % B <sub>2</sub> O <sub>3</sub> , 4 % MgO, 1 % Na <sub>2</sub> + K <sub>2</sub> O
Portion organic substance	: < 1 % (combust at first heating-up)
Density (g/cm <sup>3</sup> )	: 2,5
Temperature resistance	: 500°C/550°C
Degree of moisture	: 1%
Annealing loss	: 0,6%
Shrinking	: 500°C = 0 %
Resistance against	: Oil, grease, water, temporay steam, and numerous low organic acids/solvents. Good resitance against sudden heatwaves. Good thermal electrical and acoustical insulation resistance: Toxicologically harmless. No handling abligations.

**4.4 Technical data switches**

**1. General table**

Switch	1690	1690ATEX	LMS-A	LMS-A-EEExd	MS09K	MS10 EEExd
<b>Case</b>	synthetic	synthetic	Al Si 12	Al Si 12	synthetic	Aluminium
<b>Contact Function</b>	bistable change-over contact	bistable change-over contact	bistable change-over contact**	bistable change-over contact	break- or make-contact, change-over contact	break- or make-contact, change-over contact
<b>Dimensions</b>	20x15x80	20x15x80	65x65x40	∅138x80	110x75x50	120x120x110
<b>Breaking on rupturing capacity</b>	230 VAC	230 VAC	12-250 VAC	220 VAC	250 VAC	250 VAC
	0,8 A	0,4 A	1,5 A	1,5 A	10 A	10 A
	60 VA	30 VA	80 VA	80 VA	---	---
<b>Protective System</b>	IP65	IP65	IP65 DIN40050	IP65 DIN40050	IP65 DIN40050	IP65 DIN40050
<b>Option</b>	IP67 DIN40050	IP67 DIN40050	---	---	---	---
<b>Switch-hysteresis</b>	15 mm	15 mm	8-12 mm	8-12 mm	---	---
<b>Medium-temperature</b>	max. 130°C	max. 130°C	max. 200°C*	max. 200°C*	max. 100°C	max. 200°C
<b>EEEx-protection</b>	---	EEEx m II CT6	---	EEEx d II CT6	---	EEEx d II CT6
<b>Connection</b>	---	---	PG7,5	4 connection (¾" NPT)	PG11	¾" NPT

Electric connection with 3-channel plug and earth.

For all switches valid the international standard EN 60529.

\* Type LMS-AH with heat-protection-execution through a max. temperature of 400°C.

\*\* available with gold contact.

**2. NI Ex NU-Switch**

Inherent safety EEx-switch, on request with define error message.

<b>Contact-transmitter</b>	Supply voltage:	8 V DC
	Max. temperature:	60°C
	Cable connection at the case:	PG11
<b>Section switch appliance</b>	Supply voltage:	220 V +15 % (45-60 Hz)
	Power consumption:	Ca. 1,5 V
	Open circuit voltage:	8 V DC
	Admit charge:	4 A/250 V/ 250 VA
	Admit temperature:	-20...+60°C

**3. Switch diagrams**

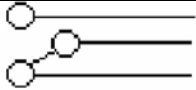
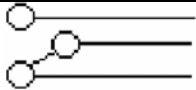
Type	Diagram
1690	 <p>bistable change-over contact</p>
LMS-A	 <p>bistable change-over contact</p>
LMS-AH	 <p>bistable change-over contact</p>

**Switch LMS-A**

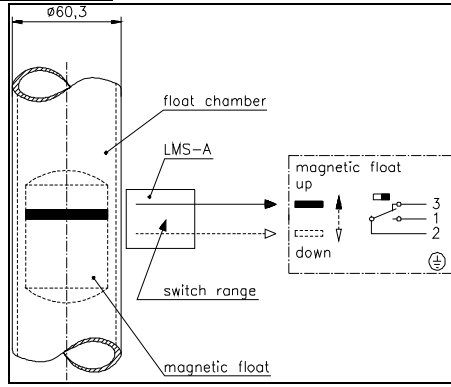

**Switch LMS-AH**

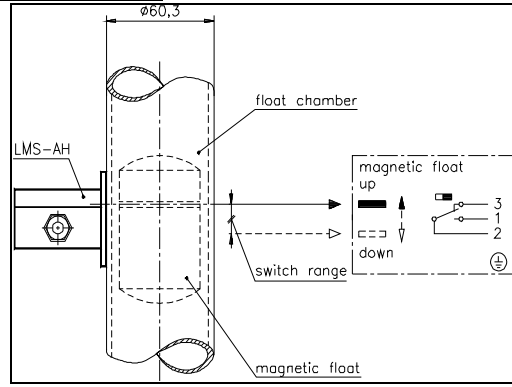

**Switch 1690 / 1690ATEX**

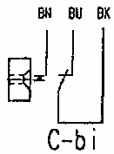
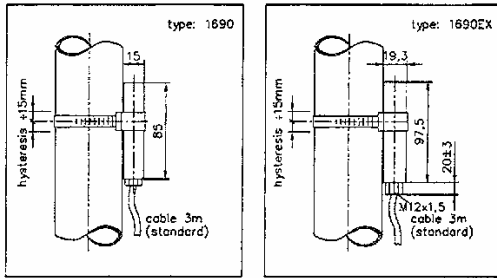

**Switch MS09 K**

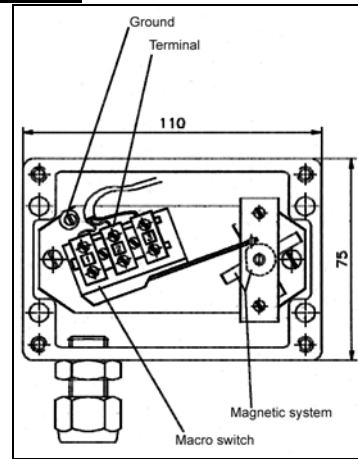

**Switch MS10 EExd**

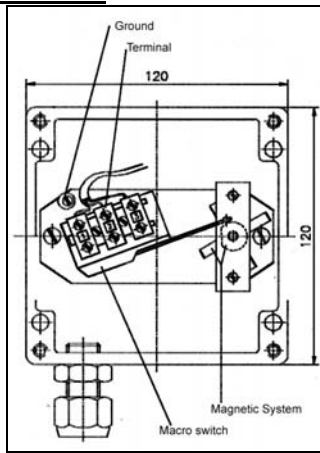

**Switch LMS-A-EExd**

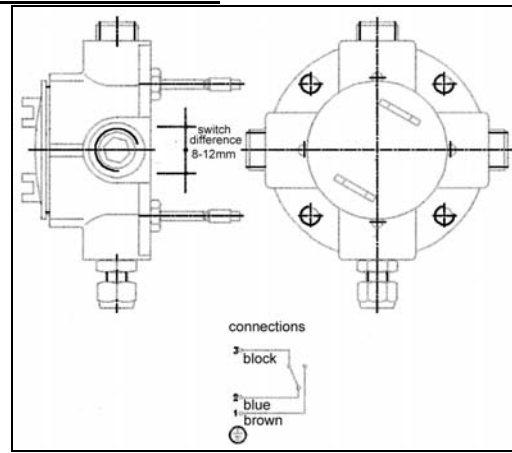

Switch NI Ex NJ

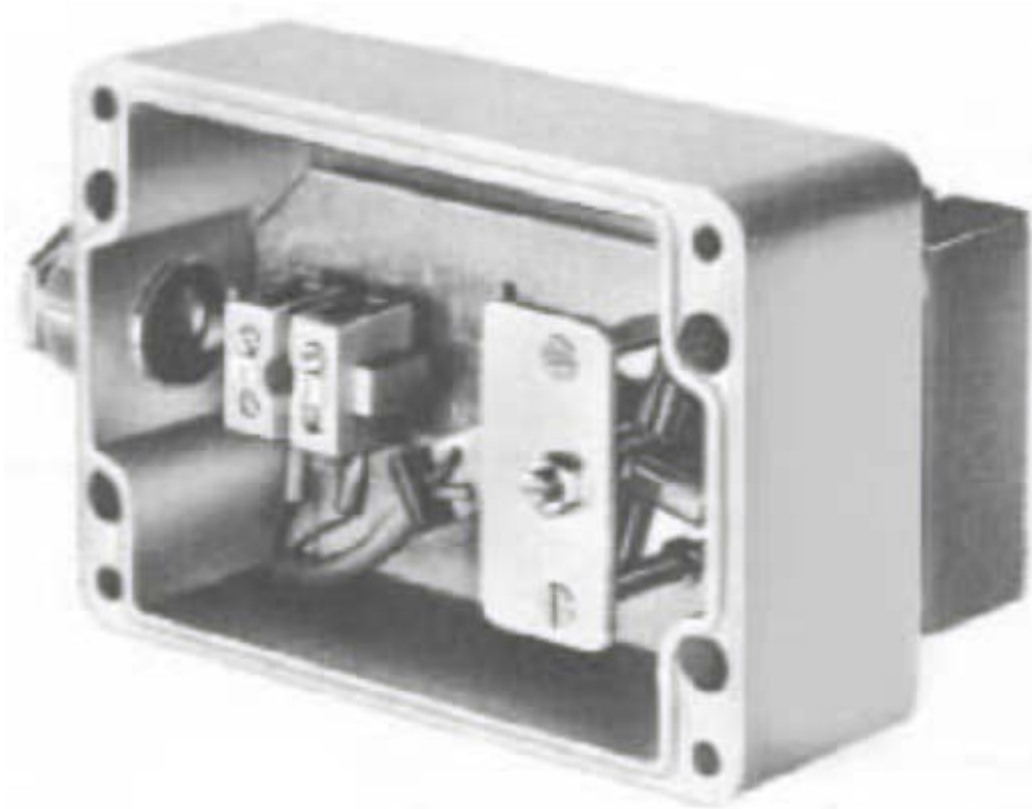
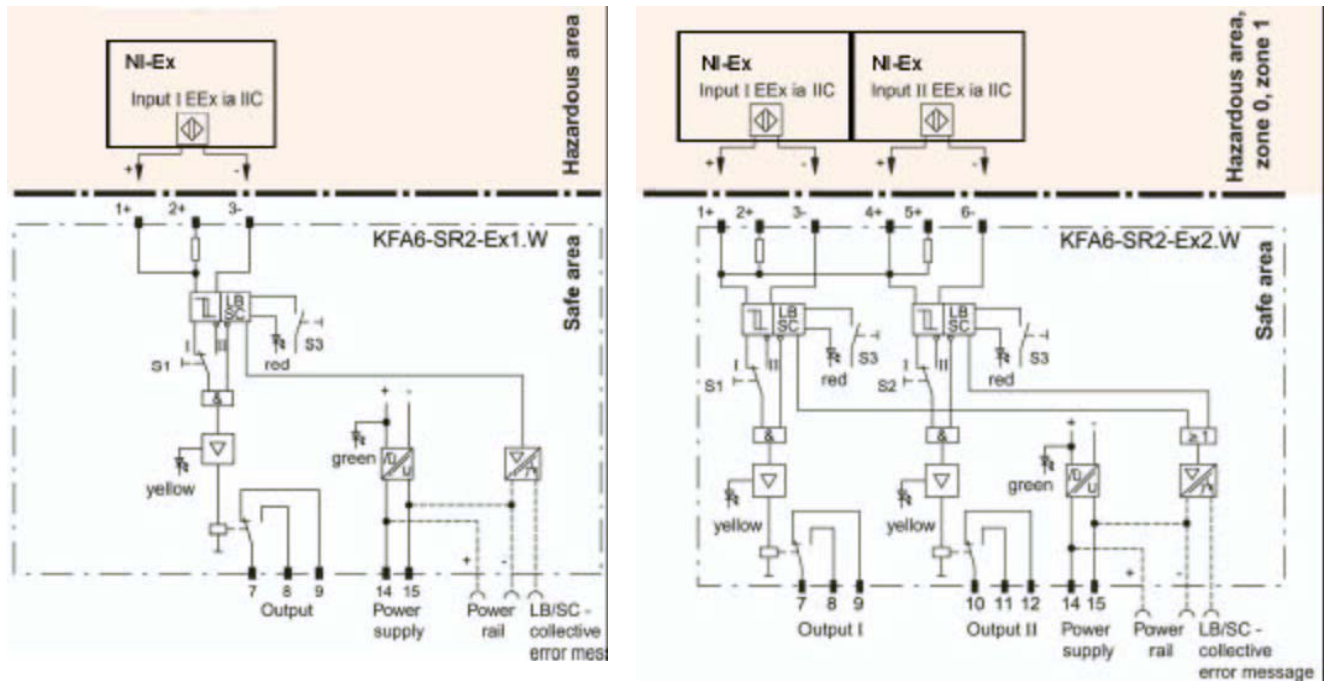

Switch NI-Ex-NJ



## 4.5 Contact NJ-EX

The contact NJ-EX is an inductive contact NJ 1.5-6.5 N, kontex System, Protective system EEx ia IIC T6.

### Function

Actuation is provided by the magnet installed in the float. The follow magnet system of the contact maker moves the switching disk, which serves for releasing the contact between two small inductances of the slotted initiator and thereby varies the attenuation of the resonant circuit.

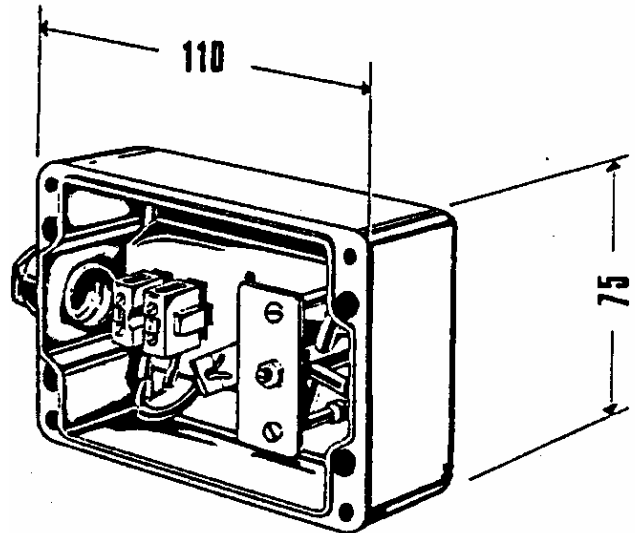

### Technical data

Electrical connection : 8 V DC  
Temp./ambient temp. : 60°C  
Cable connections : M20x1,5

### Switch relay

KFA6-SR2-Ex1.W : for 1 inductive contact EEx ia IIC  
KFA6-SR2-Ex2.W : for 2 inductive contacts EEx ia IIC

**4.6 Indication rails**

**Armaflex-insulation and heating tape ITA**

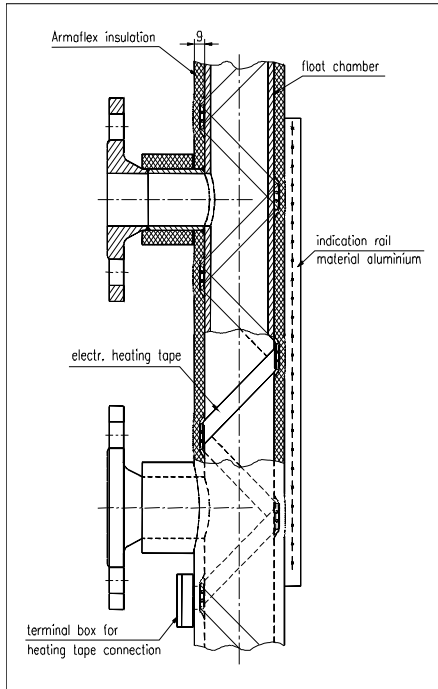

**Indication rail with scale for ITA**

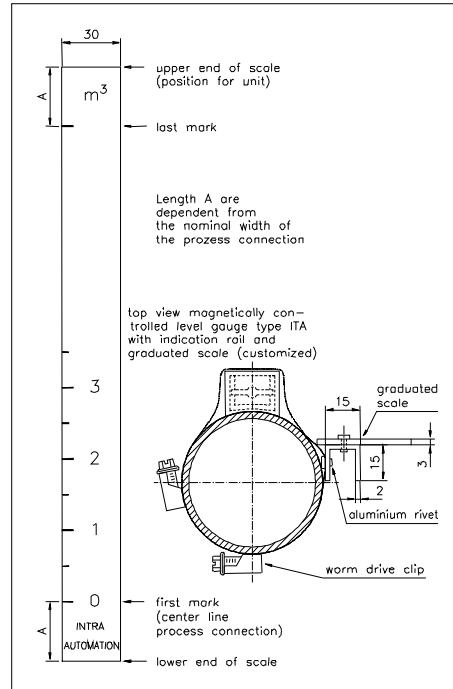

**Indication rail, mat. Makrolon**

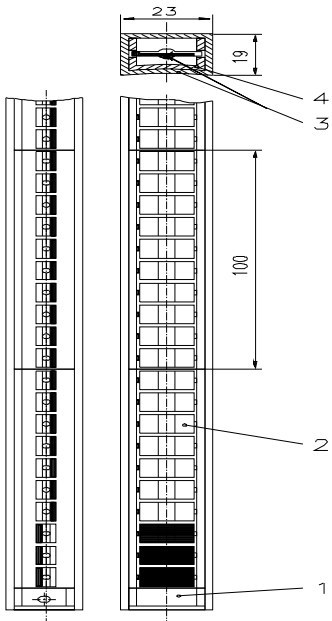

- 1. Sealing cap
- 2. Indication lamina with magnet
- 3. Rectangular profile
- 4. U-profile

**Indication rail, mat. Aluminium**

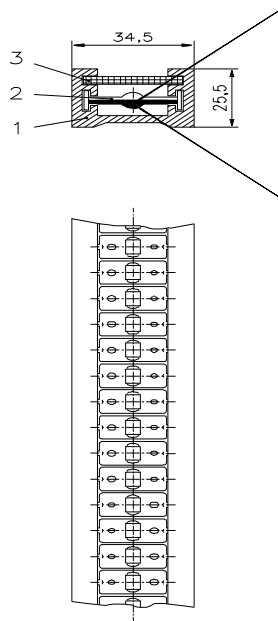

- 1. U-profile
- 2. Indication lamina with magnet
- 3. Transparent covering

**Indication rail, material 316SS**

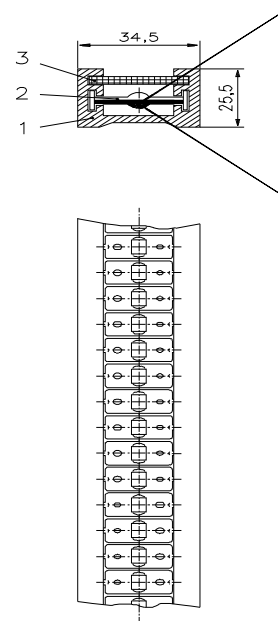

- 1. U-profile
- 2. Indication lamina with magnet
- 3. Transparent covering

#### 4.7 Digital indication with volume linearization

Electrical level measurement transducers which use the displacement principle must be recalibrated each time the fluid density is changed.

The price of a magnetically controlled level indicator with integral electrical measurement transducer is considerably lower than level measurement transducers.

The reed chain with an R/I-measurement transducer can be changed without interrupting operation. The measurement chamber is hermetically sealed – there is no contact between the fluid chamber and the reed chain.

With the microprocessor-controlled level indicator unit type 420, the level can be displayed directly in any arbitrary physical measurement unit. The indicator has a curve calculator with which non-linear tank contents can be displayed directly in cubic meters.

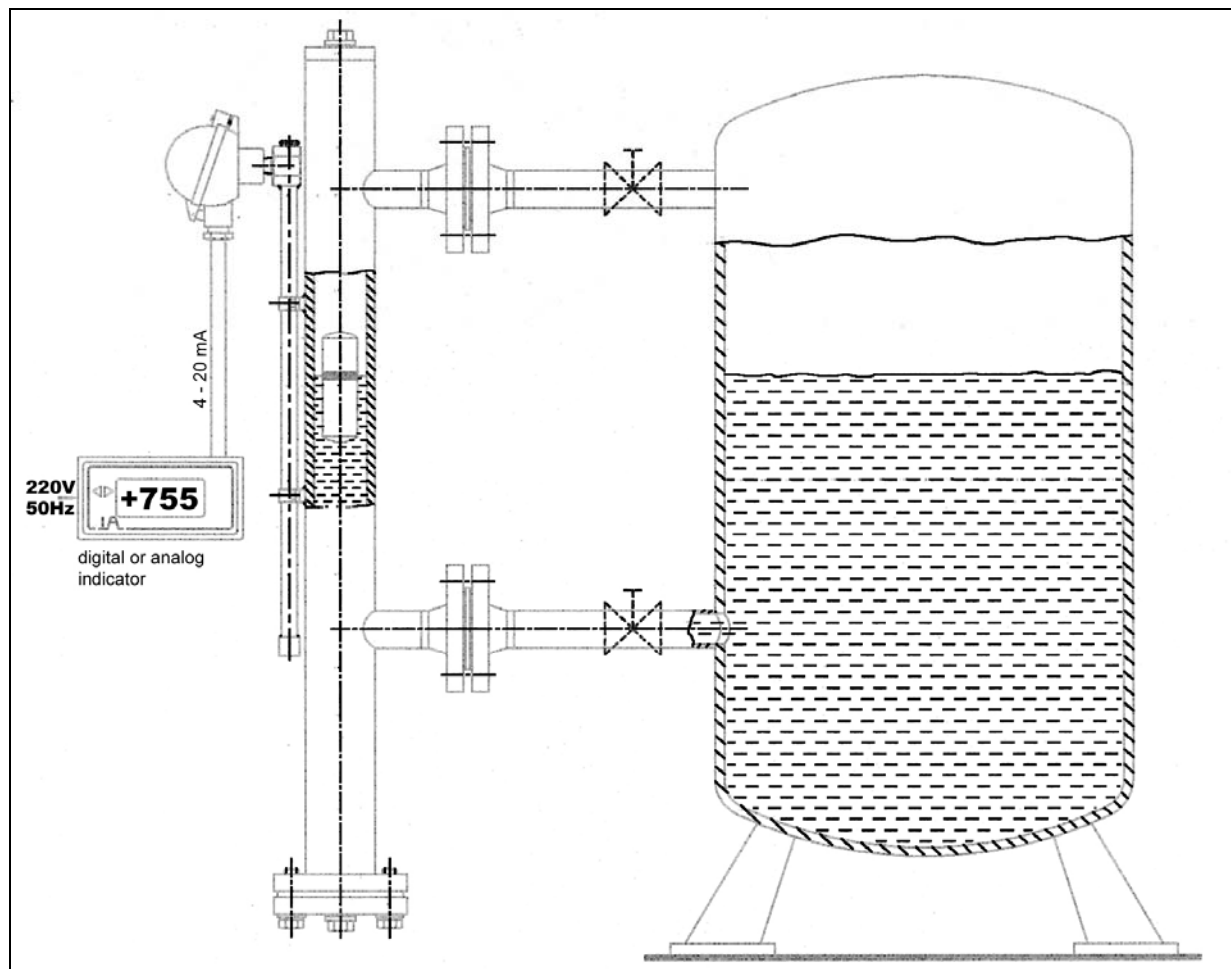

**4.8 Niveau-source**

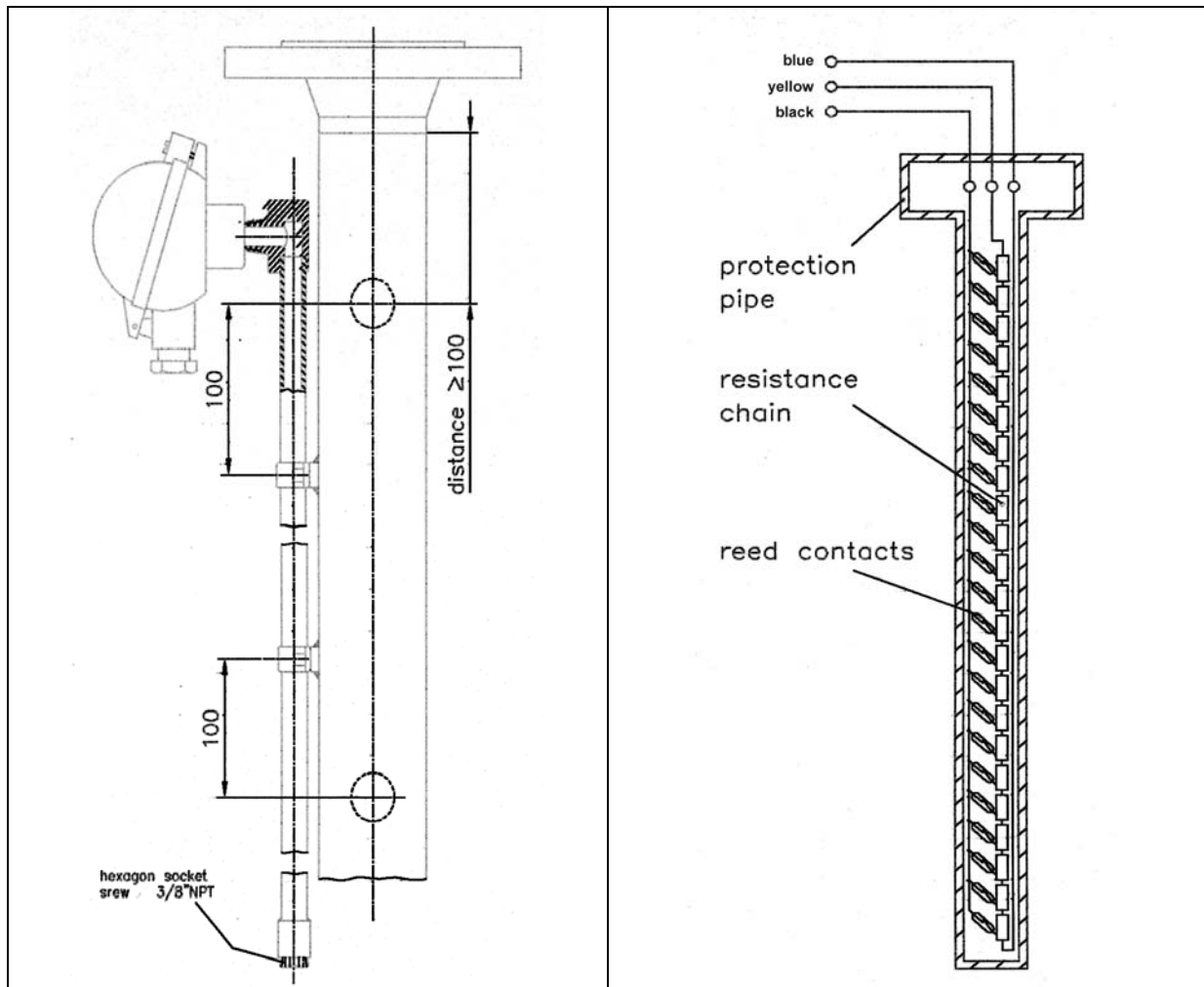

**Measuring principle:**

The resistance chain with the reed contacts are built in a pipe made of material 316SS. This so-called "Reed-chain" is mounted on the float chamber with tube clamps. According to the movement of the float, the float magnet closes one reed contact which produces a voltage (or resistance) proportional to the height of the liquid in the tank. You get a near-analogous output signal, with a resolution of about 10 mm.

The resistance chain receives its power supply from the transmitter. The 4...20 mA transmitter output signal can be transferred to an indicator or can be used to drive alarm contacts. In the case of an error the output signal becomes higher than 22 mA.

**Connection:**

As a standard, the reed chain is supplied with a transmitter that is installed inside the housing-head, 2-wire connection to the transmitter is only required.

**4.9 Reed-contact**

**Standard reed chain**

Max. medium temperature: 150 °C  
 Protection pipe: Ø14 mm  
 Material: 316Ti  
 Enclosure: IP65

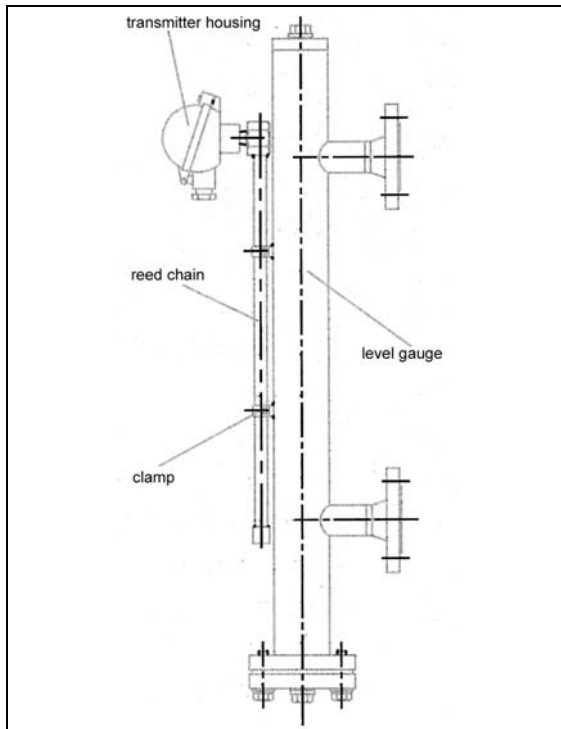

**Reed chain for higher temperature**

Max. medium temperature: 400 °C  
 Protection pipe: Ø14 mm  
 Material: 316Ti  
 Enclosure: IP65  
 Heat protection: 50x4 mm

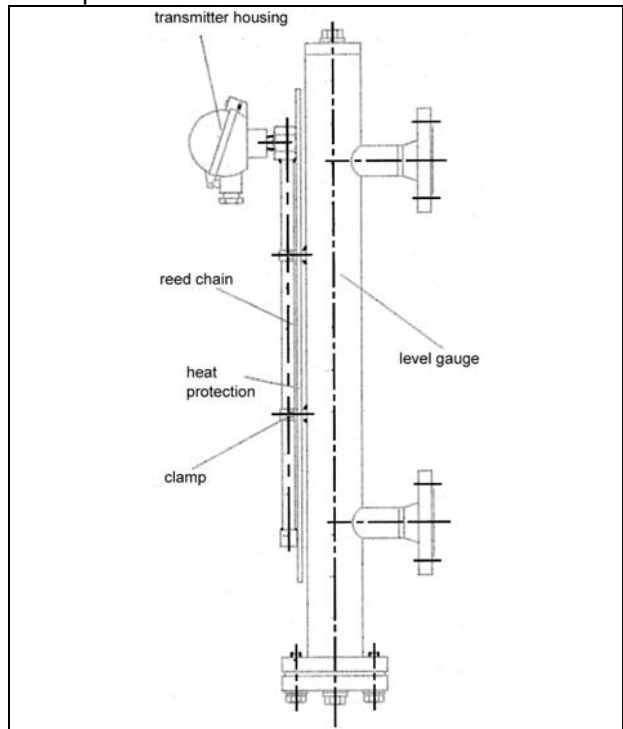

**Clamp standard**

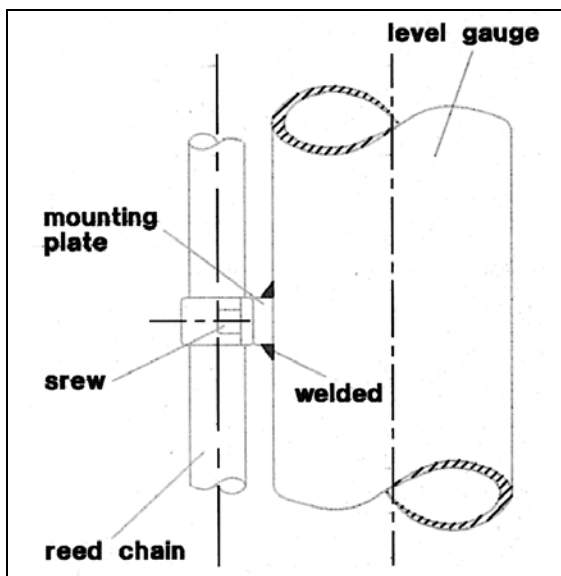

**Clamp special**

Will be needed by Armaflex isolation and secondary mounting off a reed chain.

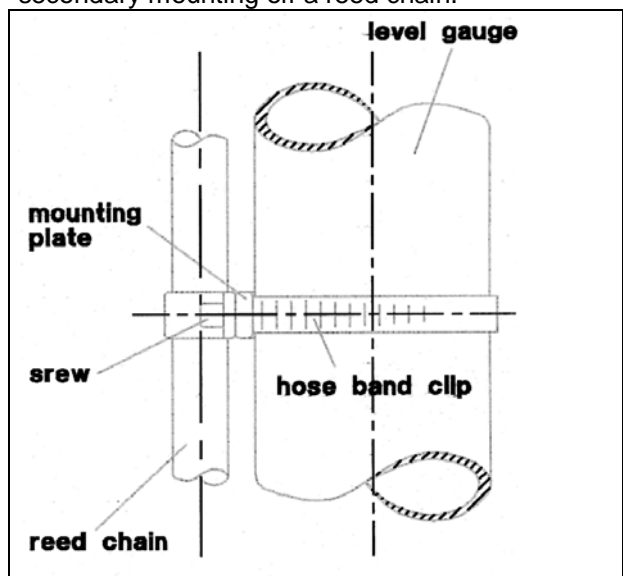

### 4.10 Magnetostrictive level transmitter

#### Datasheet M-300, M-400

#### Description:

Magnetostrictive transmitter for mounting to a level gauge type ITA

M-300/M-400 series working on the magnetostrictive principle is high accuracy transmitter for affordable price. The float inside of the level gauge type ITA containing a magnet moves along the magnetostrictive wire. A pulse generated by the electronics travels along the wire. When the pulse reaches the float's magnetic field, a twist develops in the wire. Reflected from the torsion point, the pulse creates an acoustic wave that travels back along the wire. The 4...20 mA output from the transmitter is proportional to the level.

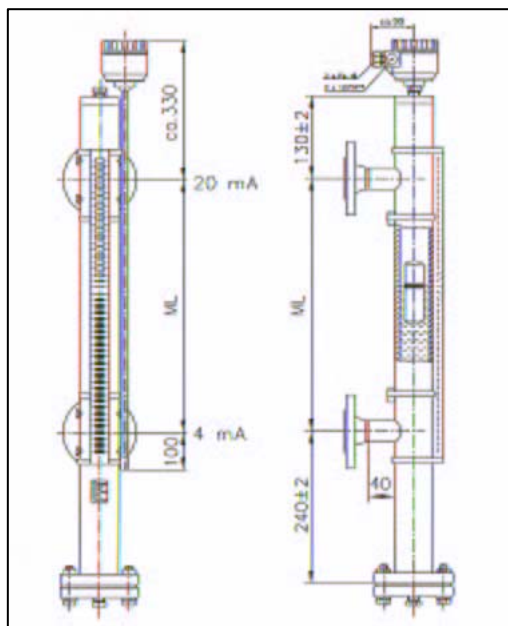

#### Technical data:

Type	rigid version	flexible version
principle/design:	magnetostrictive 2-wire transmitter	
measured process values:	level, interface level	
sensor length:	0,5...3 m	3...10 m
materials	Stainless steel (1.4571 – DIN)	
sensor:	Aluminium, powder paint coated or plastic (PBT)	
housing:	depends on the level gauge type ITA	
max. pressure:	Max. +150°C (+400°C for high-temperature-version)	
Temperature	-25°C...+70°C*	
Medium:		
Ambient:		
linearity with dry calibration:	±1 mm	
resolution:	1 mm or 5 mm (depends on order)	
temperature coefficient:	0,04 mm/°C	
measuring range:	min. 200 mm	
medium density:	depends on the level gauge type ITA	
outputs	4...20 mA or 20...4 mA	
analogue:	Hart	
serial:	6 digits (7 mm characters) icon; bargraph	
display:	0...60 s programmable	
damping:	3,8 mA or 22 mA	
error indication:	Rt=(Us-12V)/0,02 A; Us= voltage of power supply	
output load:	12...36 V DC	
power supply:	Ex II 1 G EEx ia IIB T6 (0,5...5 m) Ex II 1 G EEx ia IIA T6 (3...10 m)	
ATEX approval:	U <sub>max</sub> =30 V; I <sub>max</sub> =80 mA; P <sub>max</sub> =0,8 W; C <sub>i</sub> <30 nF; L <sub>i</sub> <200 µH	
intrinsically safe area:	class III	
protection	IP67	
electric:	cable gland PG16 or M20x1,5	
ingress:	cable diameter: Ø8...Ø15 mm; wire cross section: max. 1,5 mm <sup>2</sup>	
electrical connection:	1,7kg + sensor (sensor = 0,6 kg/m)	1,7kg + sensor (sensor = 0,6 kg/m+12 kg)
weight:		

\* temperature classification for Ex-application

**Temperature classification for Ex-Application**

temperature class	ambient temperature	process temperature
T6	-25...+70 °C	Max. 400 °C, because no wetted parts
T5	-25...+59 °C	
T4	-25...+45 °C	

**Order specification:**

<b>M</b>	<b>Magnetostrictive Level Transmitter</b>		
	<b>Function</b>		<b>/sensor design (depends on tube length)</b>
<b>T</b>	with transmitter	/rigid sensor (0,5...3 m); flexible (> 3 m)	
<b>B</b>	with transmitter and display	/rigid sensor (0,5...3 m); flexible (> 3 m)	
	<b>Connection to level gauge type ITA®</b>		
<b>U</b>	Direct welded clamps; st. st.		
<b>UX</b>	Hose band clips; st.st.		
-			
	<b>material electronic housing</b>		
<b>3</b>	Aluminium/powder paint coated		
<b>4</b>	Plastic (PTB fiber-glass reinforced, flame retardant)		
	<b>Measuring length</b>		
<b>ML</b>	measuring length in mm		
-			
	<b>Output</b>	<b>/resolution</b>	<b>/approval</b>
<b>2</b>	4...20 mA	/1 mm	
<b>4</b>	4...20 mA; Hart	/1 mm	
<b>6</b>	4...20 mA	/1 mm	/Ex
<b>8</b>	4...20 mA; Hart	/1 mm	/Ex
<b>A</b>	4...20 mA	/5 mm	
<b>E</b>	4...20 mA; Hart	/5 mm	/Ex

<b>M</b>			-			-	
----------	--	--	---	--	--	---	--

**4.11 Transmitters**

**Available housings**

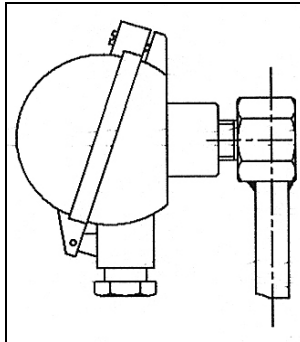

Standard-transmitter-housing  
 ◆ material aluminium  
 ◆ PG16 entry

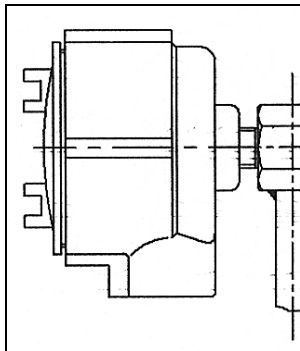

EExd transmitter housing  
 ◆ material aluminium epoxy coated  
 ◆ 1/2" NPT cable entry

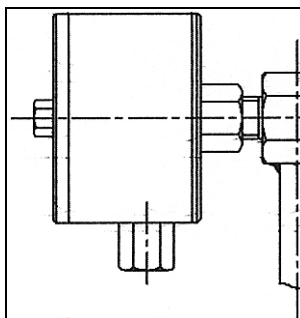

Stainless steel transmitter housing  
 ◆ material 316Ti  
 ◆ M20-1,5 entry

**Available transmitters**

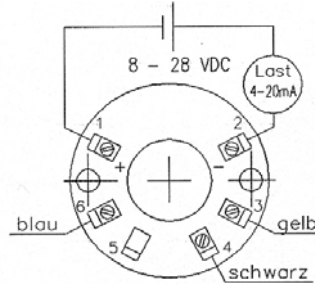

Type: INT5333B  
 ◆ EEx ia IIC T5/T6  
 ◆ output: 4...20 mA  
 ◆ power supply: 2...36 VDC  
 ◆ linearity: ± 1 %

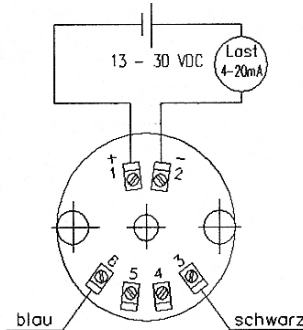

Type: TMT182  
 ◆ Eexia IIC T4  
 ◆ output: 4...20 mA (Hart-protocol)  
 ◆ power supply: 13...30 V DC  
 ◆ linearity:  
 400 Ω-area ± 0,04 Ω  
 4000 Ω-area ± 0,5 Ω  
 ◆ input:  
 5...400 Ω/50...4000 Ω



Transmitter type INT5333

## **INT5333 2-wire programmable Transmitter**



## **2-WIRE PROGRAMMABLE TRANSMITTER INT5333**

- ◆ RTD or Ohm input
- ◆ High measurement accuracy
- ◆ 3-wire connection
- ◆ programmable sensor error value
- ◆ for DIN form B sensor head mounting

### **Application:**

- Linearised temperature measurement with Pt100...Pt1000 or Ni100...Ni1000 sensor
- Conversion of linear resistance variation to a standard analogue current signal, for instance from valves or Ohmic level sensors

### **Technical characteristics:**

- Within a few seconds the user can program INT5333 to measure temperatures within all RTD ranges defined by the norms.
- The RTD and resistance inputs have cable compensation for 2- and 3-wire connection.

### **Mounting / installation:**

- For DIN form B sensor head or DIN rail mounting with a special fitting.

**Order information:**

<b>Type</b>	<b>Version</b>	
<b>INT5333</b>	<b>Standard</b>	<b>: A</b>
	<b>EEx</b>	<b>: B</b>
	<b>FM and EEx</b>	<b>: C</b>

**Electrical specifications:**

**Specifications range:**

-40...+85 °C

**Common Specifications:**

Supply voltage, DC

Standard, 5333A..... 8...35 V

EEx and FM, 5333B and C..... 8...28 VDC

Internal consumption..... 35 mW...0,8 W

Voltage drop..... 8 VDC

Warm-up time..... 5 min.

Communications interface..... Loop Link 5905

Signal/noise ratio..... min. 60 dB

Response time (programmable)..... 0,33...60 s

Signal dynamics, input..... 19 bit

Signal dynamics, output..... 16 bit

Calibration temperature..... 20...28 °C

Accuracy, the greater of general and basic values:

<b>General values</b>		
<b>Input type:</b>	<b>Absolute accuracy</b>	<b>Temperature coefficient</b>
All	≤ ± 0,1 % of span	≤ ± 0,1 % of span / °C

<b>Basic values</b>		
<b>Input type</b>	<b>Basic accuracy</b>	<b>Temperature coefficient</b>
RTD	≤ ± 0,3 °C	≤ ± 0,01 °C / °C
Lin. R.	≤ ± 0,2 Ω	≤ ± 20 Ω / °C

EMC immunity influence.....	≤ ± 0,5 % of span
-----------------------------	-------------------

Effect of supply voltage variation..... ≤ 0,005 % of span /VDC

Vibration..... IEC 68-2-6 Test FC

Lloyd's specification no. 1..... 4 g / 3...100 Hz

Max. wire size..... 1 x 1,5 mm<sup>2</sup>

Humidity..... < 95 % RH (non-cond.)

Dimensions..... Ø 44 x 20,2 mm

Tightness (enclosure/terminal)..... IP68 / IP00

Weight..... 50 g

**Electrical specifications, input:**

<b>RTD type</b>	<b>Min. value</b>	<b>Max. value</b>	<b>Min. span</b>
Pt100	-200 °C	+850 °C	25 °C
Ni100	-60 °C	+250 °C	25 °C
Lin.R	0 Ω	10000 Ω	30 Ω

**RTD and linear resistance input:**

Max. offset.....	50 % of selec. max. value
Cable resistance per wire (max.).....	10 Ω
Sensor current.....	> 0,2 mA, < 0,4 mA
Effect of sensor cable resistance (3-wire).....	< 0,002 Ω/Ω
Sensor error detection.....	Yes

**Output:****Current output:**

Signal range.....	4...20 mA
Min. signal range.....	16 mA
Updating time.....	135 ms
Load resistance.....	$\leq (V_{\text{supply}} - 8) / 0,023 [\Omega]$
Load stability.....	$< \pm 0,01 \%$ of span / 100 Ω

**Sensor error detection:**

Programmable.....	3,5...23 mA
NAMUR NE 43 upscale.....	23 mA
NAMUR NE 43 downscale.....	3,5 mA

**Ex data:**

$U_i$ .....	28 V DC
$I_i$ .....	120 mA DC
$P_i$ .....	0,84 W
$L_i$ .....	$\leq 10\mu\text{H}$
$C_i$ .....	$\leq 1 \text{ nF}$

**EEx approval CENELEC:**

DEMKO 03.....	ATEX 134705X
ATEX.....	0539 Ex II 1 G EEx ia IIC T1...T6
Max. amb. temperature for T1...T4.....	85 °C
Max. amb. temperature for T5 and T6.....	60 °C
Applicable in zone.....	0, 1 or 2
FM.....	IS, Cl. I, Div.1, Gp. A-D
Entity, FM control drawing no.....	5300Q502

**Observed authority requirements:**

EMC 89/336/EEC, Emission.....	EN50081-1, EN50081-2
Immunity.....	EN50082-2, EN50082-1
ATEX 94/9/EC.....	EN50014 and EN50020
FM class number.....	3600, 3610

**Standard:**

Of span = of the presently selected range

## Transmitter type TMT184 (Profibus)

# Resistance transmitter Type: TMT 184

Head transmitter with PROFIBUS-PA® interface. Supply and digital communication using PROFIBUS-PA®, for installation in a Form B sensor head.

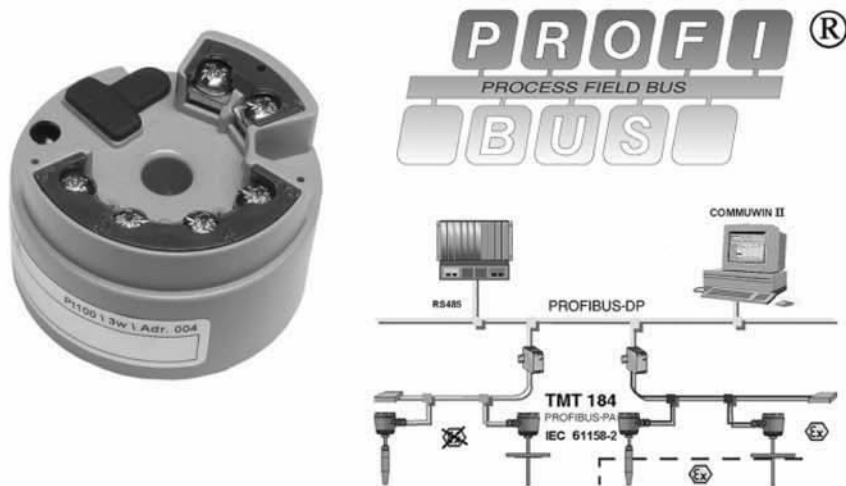

### Features and benefits:

- Universally programmable for various input signals using PROFIBUS-PA®
- DIP switch for address setting (as option)
- High accuracy in the total ambient temperature range
- EMC to NAMUR NE 21, CE
- Certification:
  - ATEX
  - FM
  - CSA
- PROFIBUS-PA® profile V3.0
- Galvanic isolation
- Customer specific address setting or expanded setup (see questionnaire page )

### Application areas:

- Applied in a PROFIBUS-PA® environment, the process industry fieldbus, an open standard to EN50170 and IEC 61158-2
- Temperature head transmitter with PROFIBUS-PA® protocol for converting various input signals into a digital output signal
- Input:
  - Resistance thermometer (RTD)
  - Thermocouple TC
  - Resistance transmitter ( $\Omega$ )
  - Voltage transmitter (mV)
- Swift and easy operation, visualization and maintenance using a PC direct from the control panel, e.g. using the COMMUWIN II operating software

# Operation and system construction

## Measurement principle

Electronic measurement and conversion of input signals in industrial temperature measurement.

## Measurement system

The TMT184 temperature head transmitter is a 2-wire transmitter with measurement inputs for resistance thermometers and resistance transmitters in 2-, 3- or 4-wire connection, thermocouples and voltage transmitters. Applications are in the measurement and control areas for process monitoring. The TMT184 setup is done using the PROFIBUS-PA® protocol combined with a PC operating software (e.g. COMMUWIN II).

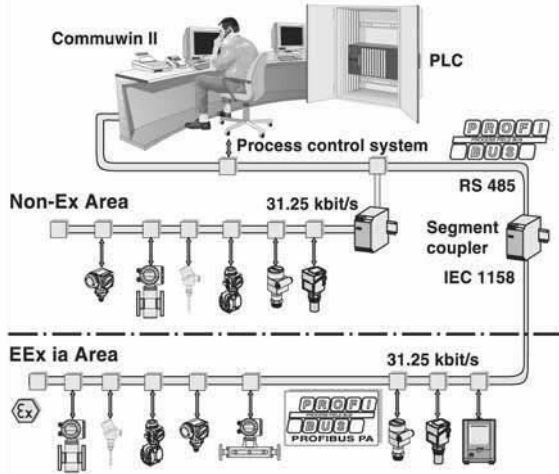

PROFIBUS-PA® is an open field bus standard in accordance with EN50170 and IEC61158-2, which has been specifically designed to handle the requirements of the process industry. In the simplest case a complete measurement circuit consists of a TMT184 fitted into a temperature sensor, a segment coupler, a PROFIBUS-PA® connection resistance, a PLC or a PC with an operating software.

The maximum number of transmitters that can be connected per bus segment is determined by the transmitter consumption, the maximum power of the segment coupler as well as the required bus length.

Normally:

- max. 9 TMT184 in an EEx ia explosion hazardous area per bus segment.
- max. 32 TMT184 in a non-explosion hazardous area per bus segment.

More detailed information for detailed project planning can be found in the operating manual. See further documentation on page .

## Input values

**Measurement value:** Temperature (temperature linear), resistance and voltage

**Measurement range:** Dependent on the sensor connection and input signal the transmitter evaluates a number of different measurement ranges.

## Type of input:

	Type	Measurement ranges	Min. measurement range
Resistance thermometer (RTD)	Pt100 Pt500 Pt1000 acc.to IEC 751	-200...850 °C (-328...1562 °F) -200...250 °C (-328... 482 °F) -200...250 °C (-328... 482 °F)	10 K 10 K 10 K
	Ni100 Ni500 Ni1000 acc.to DIN43760 - Connection type: 2-, 3- or 4-wire connection cable resistance compensation possible in the 2-wire system (0...30 Ω) - Sensor cable resistance: max. 11 Ω per cable - Sensor current: ≤ 0.2 mA	-60...250 °C (-78...482 °F) -60...150 °C (-78...302 °F) -60...150 °C (-78...302 °F)	10 K 10 K 10 K
Resistance transmitter	Resistance (Ω)	10...400 Ω 10...2000 Ω	10 Ω 100 Ω
Thermocouples (TC)	B(PtRh30-PtRh6) C(W5Re-W26Re) <sup>I</sup> D(W3Re-W25Re) <sup>I</sup> <b>E(NiCr-CuNi)</b> J(Fe-CuNi) K(NiCr-Ni) L(Fe-CuNi) <sup>II</sup> <b>N(NiCrSi-NiSi)</b> R(PtRh13-Pt) S(PtRh10-Pt) T(Cu-CuNi) U(Cu-CuNi) <sup>II</sup> MoRe5-MoRe41 <sup>III</sup> acc.to IEC 584 Part 1 - Cold junction: internal (Pt100) - Cold junction accuracy: ± 1 K	0...1820°C (32...3308 °F) 0...2320°C (32...4208 °F) 0...2495°C (32...4523 °F) -270...1000°C (-454...1832 °F) -210...1200°C (-346...2192 °F) -270...1372°C (-454...2192 °F) -200...900°C (-328...1652 °F) -270...1300°C (-454...2372 °F) -50...1768°C (-58...3214 °F) -50...1768°C (-58...3214 °F) -270...400°C (-454...752 °F) -200...600°C (-328...1112 °F) 0...2000°C (32...3632 °F)	500 K 500 K 500 K 50 K 50 K 50 K 50 K 50 K 50 K 500 K 500 K 50 K 50 K 50 K
Voltage transmitters (mV)	Millivolt transmitter (mV)	-10...75 mV	5 mV

I: according to ASTM E 988

II: according to DIN 43710

## Output values

### Output signal

Physical data transmission (Physical layer type):  
 Fieldbus interface in acc. to IEC 61158-2.

### Failure signal

Status message acc. to the PROFIBUS-PA® profile V3.0 specification.

### Galvanic isolation

2 kV AC

### Filter

Digital filter 1<sup>st</sup> degree 0...60 s

### Current consumption

10 mA ± 1 mA

### Error current

0 mA

### Switch on delay

- 10 s

### Data transmission speed

31,25 kBit/s, voltage mode

### Signal code

Manchester II

## Auxiliary energy

### Electrical connection

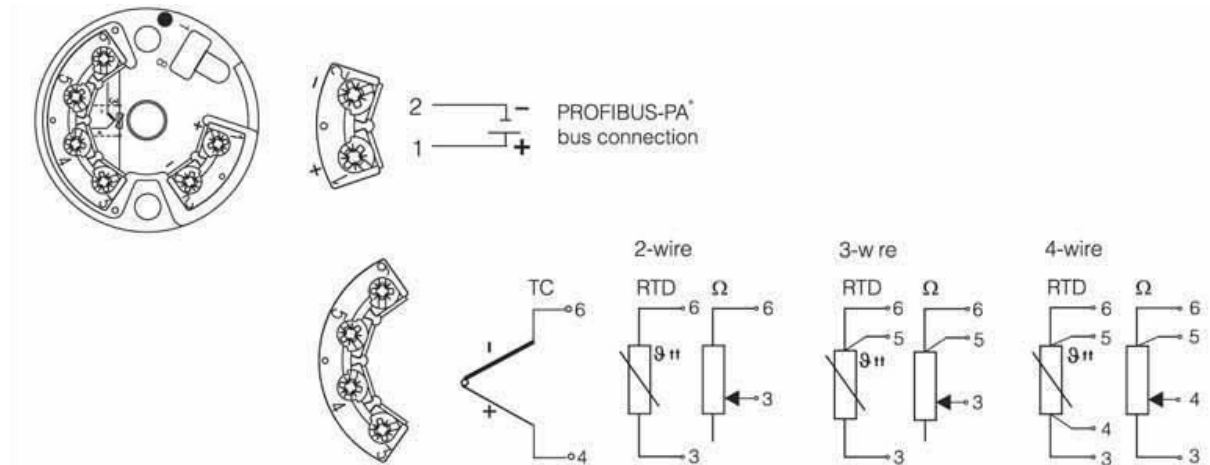

Head transmitter terminal layout

### Power supply

U<sub>b</sub> = 9...30 V DC non Ex area, polarity protected

U<sub>b</sub> = 9...15 V DC Ex area, polarity protected

## Accuracy

**Response time:** 1 s

**Reference conditions:** Calibration temperature: +23 °C ± 5 K

**Maximum measured error:**

	Type	Measurement accuracy <sup>1</sup>
<b>Resistance thermometer (RTD)</b>	Pt100, Ni100	0,15 K
	Pt500, Ni500	0,5 K
	Pt1000, Ni1000	0,3 K
<b>Thermocouple (TC)</b>	K, J, T, E, L, U	typ. 0,5 K
	N, C, D	typ. 1,0 K
	S, V, R, MoRe5-MoRe41	typ. 2,0 K

	Measurement accuracy <sup>1</sup>	Measurement range
<b>Resistance transmitter (Ω)</b>	± 0,1 Ω or 0,08 %	10...400 Ω
	± 0,15 Ω or 0,12 %	20...2000 Ω
<b>Voltage transmitter (mV)</b>	± 20 μV or 0,08 %	-10...75 mV

**Influence of ambient temperature (temperature drift):**

Resistance thermometer:  
 $T_d = \pm(15\text{ppm/K} \cdot \text{max.meas.range} + 50\text{ppm/K} \cdot \text{preset meas range}) \cdot \Delta\delta$   
 Thermocouple:  
 $T_d = \pm(50\text{ppm/K} \cdot \text{max.meas.range} + 50\text{ppm/K} \cdot \text{preset meas range}) \cdot \Delta\delta$   
 $\Delta\delta$  = Deviation of the ambient temperature according to the reference condition

**Long term stability:** ≤ 0,1 K/year<sup>2</sup> or ≤ 0,05 %/year<sup>3 2</sup>

**Influence of reference junction:** Pt100 DIN IEC 751 Cl.B (internal reference junction for thermocouples)

## Application conditions (installation conditions)

**Installation hints:**

- installation angle: no limitations
- installation area:

connection head acc. to DIN 43729 Form B; Field housing TAF 10

## Application conditions (ambient conditions)

**Ambient temperature:** -40...+85 °C (for hazardous areas see Ex-certificate)

**Storage temperature:** -40...+100 °C

**Climate class:** acc. to EN 60654-1, Class C

**Condensation:** allowable

**Ingress protection:** IP00, IP66 installed

**Shock and vibration resistance:** 4g/2...150 Hz acc. to IEC 60068-2-6

**Electromagnetic compatibility (EMC)** Interference immunity and interference emission acc. to EN 61326-1 (IEC 1326) and NAMUR NE 21

## Mechanical construction

### Dimensions

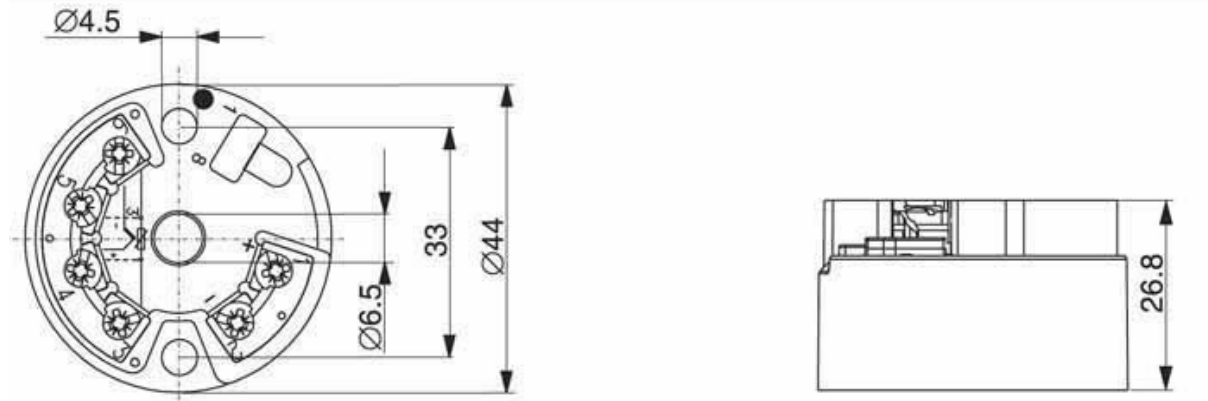

Head transmitter dimensions in mm

**Weight:** approx. 40 g

**Material:**  
- Housing: PC  
- Potting: PUR

**Terminals:** cable up to max. 1,75 mm<sup>2</sup> (secure screws)

## Display and operating system

### Remote operation

Operation via PROFIBUS-PA® using a suitable configuration or operating software.

### Certification

#### Ex-certification

Details regarding the availability of the Ex-versions (ATEX, FM, CSA etc.) can be obtained from your local sales organization. All relevant data for hazardous area protection can be found in separate Ex-documentation, which can be requested separately.

#### CE marking

The measurement system complies with the legal requirements laid out within the EU regulations.





<b>Ordering Codes for add. equipment</b>
--

Code	Description
<b>Switches</b>	
<b>S10</b>	mag. switch type 1690, 3 m cable Protection class: IP68, max. operation temperature: 120°C <b>(Art.-No. 641.6502.380LI)</b>
<b>S20</b>	mag. switch type 1690 ATEX, 3 m cable Protection class: IP67 BVS03 ATEX, max. operation temperature 120°C <b>(Art.-Nr. 610.045M1001)</b>
<b>SXK</b>	Cable length > 3 m, each additional m (please specify)
<b>SXS</b>	Hose clamp for switch 1690 and 1690 ATEX material 1.4404, 1 off each switch
<b>S30</b>	Mag. switch type LMS-A Protection class IP65, max. operation temperature: 200°C <i>(without special equipment)</i>
<b>S3G</b>	Mag. switch type LMS-A with gold plated contacts 8 VDC
<b>S3D</b>	Mag. switch type LMS-A mounted in EExd housing
<b>S3E</b>	Mag. switch type LMS-A with gold plated contacts 8 VDC + mounted in Eexd housing
<b>S40</b>	Mag. switch type: LMS-AH Protection class IP65, max. operation temperature 400°C <i>(without special equipment)</i>
<b>S4G</b>	Mag. switch type LMS-AH with gold plated contacts 8 VDC
<b>S4D</b>	Mag. switch type LMS-AH mounted in EExd housing
<b>S4E</b>	Mag. switch type LMS-AH with gold plated contacts 8 VDC + mounted in Eexd housing
<b>S50</b>	Mag. switch type NI-EX with P&F proximation initiator acc. NAMUR Protection class IP65 EExia ATEX, max. operation temperature: 60 °C
<b>S5H</b>	Mag. switch type NI-EX with P&F proximation initiator acc. NAMUR with additional heat protection, max. operation temperature: 400 °C
<b>S60</b>	Mag. switch type NI-EX with P&F proximity initiator acc. NAMUR Protection class IP65 EExia ATEX, max. operation temperature: 60 °C Protection class IP65, max. operation temperature: 100°C, max. 250VAC/10A
<b>S6H</b>	Switch type MS9, with micro switch and additional heat protection max. operation temperature: 400°C
<b>S70</b>	Switch type MS10, with micro switch Protection class IP65, max. operation temperature: 200°C, max. 250 VAC/10A mounted in Eexd housing
<b>S7H</b>	Switch type MS10, with micro switch with additional heat protection Protection class IP65, max. operation temperature: 400°C, max. 250 VAC/10A mounted in Eexd housing
<b>S80</b>	Switch type MAK9924
<b>Cable entry for switch (all switches)</b>	
<b>1</b>	M20 x 1,5
<b>2</b>	1/2" NPT
<b>3</b>	3/4" NPT
<b>Isolation amplifier for NI-EX switch</b>	
<b>T01</b>	Isolation amplifier for NI-EX switch; type: KFAG-SR2-EX1.W; one channel
<b>T02</b>	Isolation amplifier for NI-EX switch; type: KFAG-SR2-EX2.W; two channels

<b>Ordering Codes for add. equipment (Continuation)</b>
---

<b>Code</b>	<b>Description</b>
	<b>Reed chain</b>
<b>R10</b>	Reed chain, resolution 10 mm, max. 150 °C, base price
<b>L</b>	length in mm
<b>0</b>	without heat protection
<b>H</b>	with heat protection, max 400 °C / each 100 mm
<b>R05</b>	Reed chain, resolution 5 mm, base price
<b>L</b>	length in mm
<b>0</b>	without heat protection
<b>H</b>	with heat protection, max 400 °C / each 100 mm
<b>R20</b>	Reed chain, resolution 20 mm, base price
<b>L</b>	length in mm
<b>0</b>	without heat protection
<b>H</b>	with heat protection, max 400 °C / each 100 mm
<b>RXS</b>	Clamps for reed chain length > 1500 mm / 3 pcs.
	<b>Transmitter</b>
<b>M10</b>	Transmitter type: INT5333A
<b>M11</b>	Transmitter type: INT5333A with ExD-housing
<b>M12</b>	Transmitter type: INT5333A with stainless steel housing
<b>M20</b>	Transmitter type: INT5333B EX intrinsically safe
<b>M22</b>	Transmitter type: INT5333B EX intrinsically safe with stainless steel housing
<b>M30</b>	Transmitter type: INT5335A SMART/HART-technology
<b>M32</b>	Transmitter type: INT5335B Ex-proof with SMART/HART-technology with stainless steel housing
<b>M33</b>	Transmitter type: TMT-185 with Foundation Fieldbus
<b>0</b>	without Ex-protection
<b>1</b>	EExia ATEX
	<b>Cable entry for transmitter housings</b>
<b>1</b>	M20 x 1,5
<b>2</b>	1/2" NPT
<b>3</b>	3/4" NPT

**Ordering Codes for add. equipment (Continuation)**

Code	Description
	<b>Digital indicator</b>
D10	Digital indicator mounted in transmitter housing (only with reed-chain) FPM-indicator, standard version input 4-20 mA; display $\pm$ 19999
D11	Digital indicator mounted in transmitter housing (only with reed-chain) FPM-indicator, standard version input 4-20 mA; display $\pm$ 19999; EEx-version
D20	Digital indicator DA2000, input 4-20 mA; 24 VDC for 2-wire-transmitters
D21	Digital indicator DA2000, input 4-20 mA; 24 VDC for 2-wire-transmitters add. 4-20 mA-output
D22	Digital indicator DA2000, input 4-20 mA; 24 VDC for 2-wire-transmitters add- 2 off. contacts
D23	Digital indicator DA2000, input 4-20 mA; 24 VDC for 2-wire-transmitters add. 2 off contacts and 4-20 mA-output
	<b>Electronic heat tape</b>
H10	Electronic heat tape without Ex-protection, base price
H11	Electronic heat tape connection set
H12	Electronic heat tape connection socket, material CS
H20	Electronic heat tape, Ex-version
H21	Electronic heat tape connection set Ex-version
H22	Electronic heat tape connection socket, material CS / EExd housing
H23	Electronic heat tape thermostat Ex-version
	<b>Power supply</b>
SG1	Power supply 220 V / 50 Hz
	<b>Indication rail</b>
Z01	Aluminium indication rail coated (Epoxy-coat: Saekaphen); colour: white
	<b>Measuring scale</b>
Z02	Graduated scale, graved, material: plastics, base price
Z03	Graduated scale, graved, material: Aluminium, base price
Z04	Graduated scale, graved, material: 316SS, base price
	<b>Steam jacket</b>
Z05	Steam jacket, max. 6 bar, threaded connection, material 1.4404 (only available with Aluminium indication rail and Titanium float)
Z06	Steam jacket, max. 6 bar, flanged connection DN 15 PN 16 (1/2" 150#), material 1.4404 (only available with Aluminium indication rail and Titanium float)

<b>Ordering Codes for add. equipment (Continuation)</b>
---

Code	Description
	<b>Vent/drain fittings</b>
Z07	Vent-/drain valve 1/2" NPT / material 1.4401
Z08	Vent-/drain valve 1/2" NPT / material PTFE
Z09	Vent-/drain valve 1/2" NPT / material PP
Z10	Vent-/drain valve 1/2" NPT / material PVDF
Z11	Vent-/drain ball valve 1/2" NPT / material 1.4401
Z12	Vent-/drain valve 1/2" NPT, einseitig geflanscht mit DN 15 PN 16 (1/2" 150#) / material: 1.4401/1.4571
Z13	Vent-/drain valve 1/2" NPT / material: 1.4401 seitlich am Blindflansch DN50 (2"), 1.4571, angeschweißt
	<b>Insulation</b>
Z14	Low-temperature-insulation Armaflex -75...+105 °C (only available with Aluminium-indication rail and Titanium float) (each 100 mm)
Z15	Heat insulation ceramic tape; op. temperature up to 600 °C (only available with Aluminium-indication rail and Titanium float) (each 100 mm)
Z16	Insulation guide plate around indication rail, material 1.4404; height = 80 mm Equipment for Armaflex- or ceramic insulation (each 100 mm)
Z17	Makrolon window for insulation (each 100 mm)
	<b>Painting</b>
Z18	Device completely painted with RAL-colour (grounding + main paint)
	<b>Security springs</b>
Z19	Spring at top of gauge
Z20	Spring at bottom of gauge

<b>Ordering codes for special designs</b>
---

<b>Code</b>	<b>Description</b>
<b>ITA-3 GL</b>	Design for maritime and inland navigation acc. rules of "German Lloyd"
<b>ITA-6 GL</b>	Design for maritime and inland navigation acc. rules of "German Lloyd"
<b>ITA-6 D</b>	Design as steam regulator acc. TRD incl. 2 switches type: LMS-AH
<b>ITA-7-D</b>	Design as steam regulator acc. TRD incl. 2 switches type: LMS-AH
<b>ITA-3 / 3.0 Ex</b>	Design for Ex-zone 0 (following 94/9/EG: II 1 Gc IIC T1... T6)
<b>ITA-4 / 4.0 Ex</b>	Design for Ex-zone 0 (following 94/9/EG: II 1 Gc IIC T1... T6)
<b>ITA-4.1 / 4.1.0 Ex</b>	Design for Ex-zone 0 (following 94/9/EG: II 1 Gc IIC T1... T6)
<b>ITA-5 / 5.0 Ex</b>	Design for Ex-zone 0 (following 94/9/EG: II 1 Gc IIC T1... T6)
<b>ITA-6 / 6.0 Ex</b>	Design for Ex-zone 0 (following 94/9/EG: II 1 Gc IIC T1... T6)
<b>ITA-7 / 7.0 Ex</b>	Design for Ex-zone 0 (following 94/9/EG: II 1 Gc IIC T1... T6)
<b>ITA-10 / 10.0 Ex</b>	Design for Ex-zone 0 (following 94/9/EG: II 1 Gc IIC T1... T6)
<b>ITA-11 / 11.0 Ex</b>	Design for Ex-zone 0 (following 94/9/EG: II 1 Gc IIC T1... T6)
<b>ITA-12 / 12.0 Ex</b>	Design for Ex-zone 0 (following 94/9/EG: II 1 Gc IIC T1... T6)

<b>Ordering codes spare parts</b>
-----------------------------------

Code	Type	Float	max. pressure [bar]	min. density [kg/dm <sup>3</sup> ]	material	Dimensions [mm]
<b>F8C1SY</b>	ITA-3 ITA-3.0	standard, sealed	16	0,7374	1.4571	Ø52 x 270
<b>F7C2SY</b>	ITA-3 ITA-3.0	standard, sealed	16	0,5723	Titanium	Ø50,8 x 270
<b>B7C1KY</b>	ITA-3 ITA-3.0	shortened, sealed	16	1,2346	1.4571	Ø52 x 150
<b>B7C2KY</b>	ITA-3 ITA-3.0	shortened, sealed	16	0,9646	Titanium	Ø50,8 x 150
<b>G7C2SN</b>	ITA-3 ITA-3.0	low densities, sealed	16	0,4955	Titanium	Ø50,8 x 330
<b>H7C2SN</b>	ITA-3 ITA-3.0	low densities, sealed	16	0,4358	Titanium	Ø50,8 x 430
<b>K7C2SN</b>	ITA-3 ITA-3.0	low densities, sealed	16	0,4017	Titanium	Ø50,8 x 530
<b>L7C2SN</b>	ITA-3 ITA-3.0	low densities, sealed	16	0,3761	Titanium	Ø50,8 x 630
<b>N8C9KS</b>	ITA-3 ITA-3.0	coated, sealed	16	0,9020	Titanium / Halar	Ø52 x 180
<b>F8C5SY</b>	ITA-3 ITA-3.0	standard, sealed	16	0,7510	HC 4	Ø52 x 270
<b>F7C2SY</b>	ITA-3 Cryo ITA-3.0 Cryo	standard, sealed	16	0,5723	Titanium	Ø50,8 x 270
<b>K3C2SN</b>	ITA-3/3.0 Cryo, CR 60	low densities, sealed	16	0,6502	Titanium	Ø44,5 x 530
<b>K7C2SN</b>	ITA-3/3.0 Cryo, CR 64	low densities, sealed	16	0,4017	Titanium	Ø50,8 x 530
<b>E6B8SY</b>	ITA-34 ITA-3/3.0	coated, sealed	10	0,8500	PVDF	Ø50 x 255
<b>E6CASY</b>	ITA-34 ITA-3/3.0	sealed	16	0,8500	Borosilikat- glas	Ø50 x 255
<b>E8C9SY</b>	ITA-3.5 ITA-3.5.0	standard, sealed	16	0,6873	Titanium / Halar	Ø52 x 270
<b>F7C2SY</b>	ITA-4 ITA-4.0	standard, sealed	16	depends on meas. length	Titanium	Ø50,8x270
<b>F9C2SY</b>	ITA-4.1 ITA-4.1.0	standard, sealed	atm.	depends on meas. length	Titanium	Ø80x270
-	ITA-5 ITA-5.0	see ITA-3 to ITA-13				
-	ITA-5.1 ITA-5.1.0	see ITA-3 to ITA-13				

**Ordering codes spare parts (Continuation)**

Code	Type	Float	max. pressure [bar]	min. density [kg/dm <sup>3</sup> ]	material	dimensions [mm]
F8F1SY	ITA-6 ITA-6.0	standard, sealed	30	0,7738	1.4571	Ø52 x 270
F7H2SY	ITA-6 ITA-6.0	standard, sealed	40	0,6391	Titanium	Ø50,8 x 270
F8H1SY	ITA-6 ITA-6.0	standard, sealed	40	1,0000	1.4571	Ø52 x 270
B7H2SK	ITA-6 ITA-6.0	shortened, sealed	40	1,1007	Titanium	Ø50,8 x 150
G7H2SN	ITA-6 ITA-6.0	low densities, sealed	40	0,5694	Titanium	Ø50,8 x 330
H7H2SN	ITA-6 ITA-6.0	low densities, sealed	40	0,5300	Titanium	Ø50,8 x 430
K7H2SN	ITA-6 ITA-6.0	low densities, sealed	40	0,4463	Titanium	Ø50,8 x 530
L7H2SN	ITA-6 ITA-6.0	low densities, sealed	40	0,4370	Titanium	Ø50,8 x 630
F8H9SY	ITA-6 ITA-6.0	coated, sealed	40	0,7647	Titanium / Halar	Ø52 x 270
F8E5SY	ITA-6 ITA-6.0	standard, sealed	24	0,8000	HC 4	Ø52 x 270
F7H2SY	ITA-6 Cryo ITA-6.0 Cryo	standard, sealed	40	0,6391	Titanium	Ø50,8 x 270
K3H2SN	ITA-6 Cryo ITA-6.0 Cryo	low densities, sealed	40	0,6667	Titanium	Ø44,5 x 530
K7H2SN	ITA-6 Cryo ITA-6.0 Cryo	low densities, sealed	40	0,4693	Titanium	Ø50,8 x 530
F7K2SY	ITA-7 ITA-7.0	standard, sealed	64	0,6820	Titanium	Ø50,8 x 270
G7K2SN	ITA-7 ITA-7.0	low densities, sealed	64	0,6064	Titanium	Ø50,8 x 330
K7K2SN	ITA-7 ITA-7.0	low densities, sealed	64	0,4450	Titanium	Ø50,8 x 530
E6B6SY	ITA-8.1	standard, sealed	10	0,7500	PVC	Ø50 x 255
E6B7SY	ITA-8.2	standard, sealed	10	0,6500	PP	Ø50 x 255
E6B8SY	ITA-8.3	standard, sealed	10	0,8500	PVDF	Ø50 x 255
X6A6SY	ITA-9.1	standard, sealed	6	depends on meas. length	PVC	Ø50
X6A7SY	ITA-9.2	standard, sealed	6	depends on meas. length	PP	Ø50
X6A8SY	ITA-9.3	standard, sealed	6	depends on meas. length	PVDF	Ø50



**Ordering codes spare parts (Continuation)**

<b>Code</b>	<b>Type</b>	<b>Float</b>	<b>max. pressure [bar]</b>	<b>min. density [kg/dm<sup>3</sup>]</b>	<b>material</b>	<b>dimensions [mm]</b>
<b>F7L2SY</b>	ITA-10 ITA-10.0	standard, sealed	100	0,8299	Titanium	Ø50,8 x 270
<b>G7L2SY</b>	ITA-10 ITA-10.0	low densities, geschlossen	100	0,7617	Titanium	Ø50,8 x 330
<b>H7L2SY</b>	ITA-10 ITA-10.0	low densities, sealed	100	0,6779	Titanium	Ø50,8 x 430
<b>K7L2SY</b>	ITA-10 ITA-10.0	low densities, sealed	100	0,6321	Titanium	Ø50,8 x 530
<b>L7V2SN</b>	ITA-10 ITA-10.0	low densities, sealed	80	0,4632	Titanium	Ø50,8 x 630
<b>F3N2SY</b>	ITA-11 ITA-11.0	standard, sealed	160	1,0069	Titanium	Ø44,5 x 270
<b>F5N1SY</b>	ITA-11 ITA-11.0	standard, vented	160	0,7736	1.4571	Ø46 x 270
<b>G3N2SY</b>	ITA-11 ITA-11.0	standard, sealed	160	0,9059	Titanium	Ø44,5 x 330
<b>H3N2SY</b>	ITA-11 ITA-11.0	standard, sealed	160	0,8238	Titanium	Ø44,5 x 430
<b>K3N2SY</b>	ITA-11 ITA-11.0	standard, sealed	160	0,7411	Titanium	Ø44,5 x 530
<b>F2N2SY</b>	ITA-11 ITA-11.0	standard, sealed	160	0,9768	Titanium	Ø42 x 270
<b>M2N2SY</b>	ITA-11 ITA-11.0	low densities, sealed	160	0,8871	Titanium	Ø42 x 300
<b>P2N2SY</b>	ITA-11 ITA-11.0	low densities, sealed	160	0,7832	Titanium	Ø42 x 400
<b>R2N2SY</b>	ITA-11 ITA-11.0	low densities, sealed	160	0,7268	Titanium	Ø42 x 500
<b>F5R1VN</b>	ITA-12 ITA-12.0	standard, vented	250	0,7736	1.4571	Ø46 x 270
<b>F4R2VN</b>	ITA-12 ITA-12.0	standard, vented	250	0,5774	Titanium	Ø45 x 270
<b>F2R2SN</b>	ITA-12 ITA-12.0	low densities, sealed	250	0,8719	Titanium	Ø42 x 270
<b>G2R2SN</b>	ITA-12 ITA-12.0	low densities, sealed	250	0,7978	Titanium	Ø42 x 330
<b>H2R2SN</b>	ITA-12 ITA-12.0	low densities, sealed	250	0,7394	Titanium	Ø42 x 430
<b>K2R2SN</b>	ITA-12 ITA-12.0	low densities, sealed	250	0,7055	Titanium	Ø42 x 530
<b>F1R2SN</b>	ITA-12 ITA-12.0	low densities, sealed	250	0,8944	Titanium	Ø38x 270
<b>G1R2SN</b>	ITA-12 ITA-12.0	low densities, sealed	250	0,8281	Titanium	Ø38x 330
<b>G1W1VY</b>	ITA-13 ITA-13.0	standard, vented	320	0,7269	1.4571	Ø38 x 330
<b>F1W2VY</b>	ITA-13 ITA-13.0	standard, vented	320	0,5773	Titanium	Ø38 x 270

**Ordering codes spare parts (Continuation)**

<b>Code</b>	<b>Type</b>	<b>Float</b>	<b>max. pressure [bar]</b>	<b>min. density [kg/dm<sup>3</sup>]</b>	<b>material</b>	<b>dimensions [mm]</b>
F1T2SN	ITA-13 ITA-13.0	low densities, sealed	300	0,9757	Titanium	Ø38 x 270
G1W2SN	ITA-13 ITA-13.0	low densities, vented	320	0,5032	Titanium	Ø38 x 330
H1R2SN	ITA-13 ITA-13.0	low densities, sealed	250	0,8000	Titanium	Ø38 x 430
<b>E01</b>	Indication rail, max. operation temperature 100 °C					Makrolon
<b>E02</b>	Indication rail, max. operation temperature 400 °C					Aluminium
<b>E03</b>	Indication rail, max. operation temperature 400 °C					1.4301
<b>E04</b>	Gaskets for ITA-3,-7 max. operation temperature 100 °C					PTFE
<b>E05</b>	Gaskets for ITA-3,-7 max. operation temperature 400 °C					Klingersil
<b>E06</b>	Spiral wound or cam profiled gaskets for ITA-7,-11 max. operation temperature 400 °C					1.4571
<b>E07</b>	Spiral wound or cam profiled gaskets for ITA-12,-13 max. operation temperature 400 °C					1.4571
<b>E08</b>	Gaskets for all mag. level gauges, mat. plastics					Viton
<b>E09</b>	Brackets for indication rails					VA
<b>E10</b>	Gaskets for vent/drain plugs R½"					copper
<b>E11</b>						PTFE
<b>E12</b>						soft iron

**5. Special constructions**

**5.1 ITA-T1S Continuous level sensing element**

Technical information  
 ITA-T1S  
 Special features

- simple and rugged design
- reliable performance in liquids with densities of  $\geq 0,5 \text{ kg/dm}^3$
- short mounting depth  $\geq 300 \text{ mm (11.81")}$ , therefore suitable for small vessels
- indicating length up to  $3000 \text{ mm (118")}$
- resistant to pressures of  $\leq 40 \text{ bar (580 psi g)}$  and temperatures of  $\leq 130 \text{ }^\circ\text{C (266 }^\circ\text{F)}$
- housing of cast aluminium or stainless steel in IP65 equivalent to NEMA 4 and NEMA 4x enclosure
- wide variety of material combinations
- various plastic coatings available for all wetted parts
- 4...20 mA or Hart protocol 4...20 mA output via the signal conditioner



Fig1: ITA®-T1S with EExd-housing and tank mounting flange

Introduction

Intra-Automation does not limit you with the standard designs catalogued here. Our experienced engineering staff, with extensive research and development capabilities, will customize liquid level indicators to meet your specific requirements. Modifications regarding the variety of mountings, exotic materials and float configurations provide compatibility for most liquid media, various tank temperatures and pressures, as well as liquids with a broad range of specific gravities.

Operating

The ITA-T1S Liquid Level Transmitters, vertically mounted in the tank and cable connected (3-wire) to a remote receiver, operates on the float principle. A float guided on a non-magnetic tube follows the level of the liquid surface, thereby actuating the reed switches located inside the tube by means of a built-in magnet system. The reed switches shunt over parts of a resistor string. The magnet system operates the reed switches according to the position of the float and thus causes the  $\Omega$  resistance of the resistor string to change as a function for liquid level. A current 4...20 mA is then obtained as an output signal together with the INT5333; INT5333ATEX; TMT182 signal conditioner. The float travel distance can be limited by stops fitted to the guide tube.

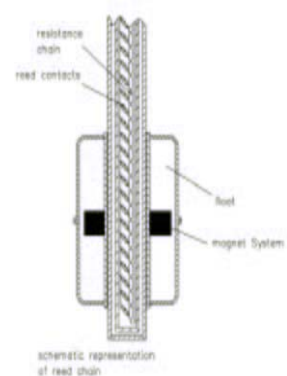

Fig2: diagrammatic view of reed switches

**Monitoring**

Combined with DigiFlow 520 these transmitters form a complete liquid level monitoring system. Used as a separate system with a process control system, Intra transmitters can interface with programmable controllers and other industrial microprocessors.



**Interface measuring**

Very often dissimilar liquids resides in a tank. Most tank gauging methods are limited in these cases and only indicate the level of the uppermost surface. But, with using Intra-Automation level sensing elements, you can easily monitor the interface between liquids. By adjusting the specific gravity of the magnet float, Intra can adapt the transmitter to monitor the interface of a broad range of media. This principle applies to oil and water, slurries, acid, bilge and other dissimilar liquids. In conjunction with DigiFlow 520 tank level, ITA-T1S will help assure that only the "correct" liquid is taken from a tank, or introduced into a process system.

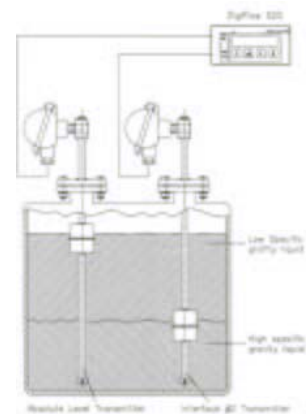

**Technical data**

Level transmitter overall length	ITA-T1S
measurement accuracy	0,3...6 m (0.98...19.69 ft)
ambient temperature	±5, 10 or 20 mm (±0.2", 0.39" or 0.79")
◆ aluminium housing	-40...+60°C (-40...+140°F)
◆ stainless steel housing	-40...+60°C (-40...+140°F)
tank product	
◆ temperature	-10...+100°C (-14...+212°F)
◆ min. density	0,5 kg/dm <sup>3</sup> (32,21 lbs/ft <sup>3</sup> )
◆ max. allowable op. Pressure	40 bar (580 psig)
protection category DIN40050/IEC144	IP65 (NEMA 4.4x)
terminals	Max. 1,5 mm <sup>2</sup> (AWG 14 cable cross sect.)
cable entry	
◆ aluminium housing	PG16 (optional M20x1.5)
◆ stainless steel housing	PG13,5 (optional M20x1.5)
current output	<i>other entries on request</i>
connection	4...20 mA (optional Hart 4...20 mA)
◆ screw connection acc. ISO	R ½"
◆ screw connection acc. ANSI/NEMA	½" NPT-M
◆ flanges acc. DIN	DN50, DN100, PN16 and PN40
◆ flanges acc. ANSI	2", 4", class 150 lbs/RF and 300 lbs/RF
materials	
housing	
◆ standard	cast aluminium (option: with epoxy finish)
◆ special	stainless steel
◆ explosion proof	cast aluminium with epoxy finish
flange	carbon steel, stainless steel (optional Halar coated), PP, PVC, PVDF
thread	stainless steel
guide tube	carbon steel, stainless steel (optional Halar coated), PP, PVC, PVDF
float	see "float type"

**Other connections on request**

**Float type**

type 1)	shape	dimensions in mm (inches)	material	min. density kg/dm <sup>3</sup> (lbs/ft <sup>3</sup> )	max. operating pressure in bar (psig) @ 20°C (68°F)	max. product temperature in °C (°F)
A	spherical	∅ 52 (2.05)	1.4571 (316 Ti)	0,7 (43.70)	40 (580)	-40...+100 (-40...+266)
B	spherical	∅ 80 (3.15)	3.7035 (Titanium)	0,6 (37.46)	17 (247)	-40...+100 (-40...+266)
C	cylindrical	∅ 80x35 (3.15x1.38)	1.4571 (316 Ti)	0,5 (31.21)	13 (189)	-40...+100 (-40...+266)
D	cylindrical	∅ 44x52	1.4571 (316 Ti)	0,8 (49.94)	25 (362)	-40...+100 (-40...+266)
E	cylindrical	∅ 32x34	Buna N	0,55	10 (150)	0...+82 (-18...+180)
F	cylindrical	∅ 32x34	Intox	0,5	100 (1450)	-40...+100 (-40...+266)

1) other types on request



float type A



float type B



float type C



float type D



float type E



float type F

**Transmitter**

Type	Output in mA	Supply voltage in VDC	Current in mA	Operating temperature in °C (°F)	Min. resistance max. resistance in Ohm	Approval
INT5333	4...20	8...28	4...20	-20...+85 (-4...+185)	50 6000	Non
TMT182	4...20	10...30	4...20	-40...+85	0...400 0...2000	EEx ia C FM IS CSA IS
TMT184	Profibus	10...35	Profibus	-40...+85	10...400 10...2000	EEx ia CII ATEX FM CSA

**Order key:**

<b>ITA-T1S</b>	Continuous Level Sensing Element	
	<b>Material of guide tube</b>	
<b>S</b>	316Ti (1.4571)	
<b>T</b>	Titanium (3.7035)	
<b>P</b>	Polypropylene	
<b>Y</b>	others	
	<b>Material of tank connection</b>	
<b>S</b>	316 Ti (1.4571)	
<b>T</b>	Carbon steel	
<b>Y</b>	others	
	<b>Type/size of tank connection</b>	
<b>R1</b>	R½"	
<b>N1</b>	½" NPT	
<b>F11</b>	Blind flange DN50 PN16 (DIN 2501)	
<b>F12</b>	Blind flange DN50 PN32 (DIN 2501)	
<b>F21</b>	Blind flange 2" 150 lbs RF (ANSI B 16.5)	
<b>F22</b>	Blind flange 2" 150 lbs RF (ANSI B 16.5)	
<b>Y</b>	other	
	<b>Measuring accuracy</b>	
<b>10</b>	± 10 mm (± 0.394")	
<b>5</b>	± 5 mm (± 0.197")	
<b>20</b>	± 20 mm (± 0.788")	
	<b>Float type</b>	
<b>A</b>	Ø52 mm; min.SG: 0,7 kg/dm³, max. p. 40 bar; mat.: 316Ti	
<b>B</b>	Ø80 mm; min.SG: 0,6 kg/dm³, max. p. 17 bar; mat.: Titanium	
<b>C</b>	Ø80x35 mm; min.SG: 0,5 kg/dm³, max. p. 13 bar; mat.: 316Ti	
<b>D</b>	Ø44x52 mm; min.SG: 0,8 kg/dm³, max. p. 25 bar; mat.: 316Ti	
<b>E</b>	Ø32x34 mm; min.SG: 0,55 kg/dm³, max. p. 10 bar; mat.: Buna N	
<b>F</b>	Ø32x34 mm; min.SG: 0,5 kg/dm³, max. p. 100 bar; mat.: Intox	
<b>Y</b>	other	
	<b>Transmitter housing</b>	
<b>A</b>	mat. cast aluminium, IP65 (NEMA4/4X), standard	
<b>S</b>	mat. 316Ti, IP65 (NEMA47/4X), standard	
<b>E</b>	mat. alu/epoxy finish, IP65 (NEMA4/4X), EExd II C T6	
<b>Y</b>	other	
	<b>Transmitter</b>	
<b>T1</b>	INT5333 non Ex	
<b>T2</b>	TMT182 non Ex	
<b>T3</b>	TMT182Ex	
<b>T4</b>	TMT184 Profibus	

<b>ITA-T1S</b>									
----------------	--	--	--	--	--	--	--	--	--

**5.2 ITA-T1R Magnetic multi-float-switch**

**Technical data:**

- Max. oper. Pressure : 40 bar, depending on mounting type and float type
- Max. temperature : 100 °C (213 °F)
- Min. oper. Temperature : depending on the float type
- Installation : vertical; ± 30°
- Protection class : IP65 (NEMA 4)
- Weight : depending on version
- Min. switch distance : float.diameter + 30 mm

**Dimensions**

- L1:** min. 30 mm (flanged version)  
min. 50 mm (screwed-mounting)
- L<sub>max</sub>:** 3000 mm

**L2-L5:** min. (float diameter + 20 mm)

**A:** min. 50 mm

**Guide tube Ø :** 14 mm

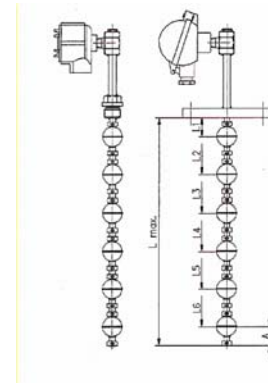

**Order coding system:**

<b>ITA-T1R</b>	<b>Magnetic Multi-Float-Switch</b>	
	Material of guide tube	
<b>S</b>	316Ti (1.4571)	
	Material of tank mounting	
<b>S</b>	316Ti (1.4571)	
<b>C</b>	Carbon steel	
	Mounting type:	
<b>R1</b>	R½"	
<b>N1</b>	½" NPT	
<b>F11</b>	Blind flange DN50 PN16 (DIN 2501)	
<b>F12</b>	Blind flange DN50 PN32 (DIN 2501)	
<b>F21</b>	Blind flange 2" 150 lbs RF (ANSI B 16.5)	
<b>F22</b>	Blind flange 2" 150 lbs RF (ANSI B 16.5)	
	Switches: 1 <input type="checkbox"/> 2 <input type="checkbox"/> 3 <input type="checkbox"/> 4 <input type="checkbox"/> 5 <input type="checkbox"/> 6 <input type="checkbox"/>	
	Switchpoint: _____ (mm)	
	Float type:	
<b>A</b>	Ø52 mm; min.SG: 0,7 kg/dm³, max. p. 40 bar; mat.: 316Ti	
<b>B</b>	Ø80 mm; min.SG: 0,6 kg/dm³, max. p. 17 bar; mat.: Titanium	
<b>C</b>	Ø80x35 mm; min.SG: 0,5 kg/dm³, max. p. 13 bar; mat.: 316Ti	
<b>D</b>	Ø44x52 mm; min.SG: 0,8 kg/dm³, max. p. 25 bar; mat.: 316Ti	
<b>E</b>	Ø32x34 mm; min.SG: 0,55 kg/dm³, max. p. 10 bar; mat.: Buna N	
<b>F</b>	Ø32x34 mm; min.SG: 0,5 kg/dm³, max. p. 100 bar; mat.: Intox	
	Connection box	
<b>S</b>	Standard (max. 2 switches); IP65 (NEMA 4)	
<b>D</b>	EExd (max. 2 switches); IP65 (NEMA 4)	
<b>K</b>	Plastic (max. 6 switches) IP65 (NEMA 4)	
<b>A</b>	Aluminium (max. 2 switches); IP65 (NEMA 4)	
	Contacts	
<b>S</b>	Normally open (NO)	
<b>O</b>	Normally closed (NC)	
	U <sub>max</sub> = 25 V; I <sub>max</sub> = 150 mA	

<b>ITA-T1R</b>							
----------------	--	--	--	--	--	--	--

**Ordering codes documentation**

General documentation

<b>Code</b>	<b>Description</b>
<b>D001</b>	Certificate of Conformity
<b>D003</b>	Drawings for special types
<b>D004</b>	Certificate of origin
<b>D005</b>	Certificate of origin by German Chamber of Commerce
<b>D006</b>	Legalised by Embassy of recipient
<b>D007</b>	Standard QA-Plan
<b>D008</b>	Inspection certificate
<b>D009</b>	QA-Manual
<b>D009a</b>	Calibration certificate
<b>D009b</b>	Legalised by Embassy of recipient
	<b>Documents on CD</b>
<b>D009c</b>	only <b>one</b> manual or technical information
<b>D009d</b>	<b>up to 4</b> manuals or technical information
<b>D009e</b>	manuals incl. e.g. 3.1B, drawings, cert. of conf. etc.
<b>D009f</b>	add. documents as paper print

Orderwise documentation

<b>Code</b>	<b>Description</b>
<b>D010</b>	Production schedule
<b>D011</b>	Manufacturing Progress Status Report
<b>D012</b>	Test Procedures (Covering Manufacturing)
<b>D013</b>	Welding Procedures (WPS, PQR), Standard material
<b>D014</b>	Welding Procedures (WPS, PQR), Special material

Material certificates

<b>Code</b>	<b>Description</b>
<b>D015</b>	Material Certificate EN 10204:2004-2.2
<b>D016</b>	Material certificates acc. EN 10204:2004-3.1, for ITA-3 to ITA-6, please advise if cast marking for pressure retaining parts required Cast marking of pressure retaining parts
<b>D016a</b>	for special material (ITA3 to ITA-6)  Cast marking of pressure retaining parts
<b>D017</b>	Material certificates acc. EN 10204:2004-3.1, for ITA-7 to ITA-13, please advise if cast marking for pressure retaining parts required Cast marking of pressure retaining parts
<b>D017a</b>	for special material (ITA7 to ITA-13)  Cast marking of pressure retaining parts
<b>D018</b>	Material certificates acc. EN 10204:2004-3.2 (former 3.1C or 3.1A)



**Ordering codes documentation (Continuation)**
**CE Declaration of conformity acc. PED 97/23/EG**

<b>Code</b>	<b>Description</b>
<b>D019</b>	<b>Category sound engineering practice</b> manufactured and tested acc. Module A1, checked against diagram 1 of PED 97/23/EG
<b>D020</b>	<b>Category I,II und III</b> manufactured and tested acc. Module H, checked against diagram 1 of PED 97/23/EG
<b>D022</b>	<b>Category IV</b> manufactured and tested acc. Modul G. Layout test and inspection by German TÜV

**Inspection and testing**

<b>Code</b>	<b>Description</b>
<b>D023</b>	Hydr. pressure test incl. test certificate
<b>D024</b>	Inspection And Pressure Testing acc. AD-Merkblatt, TRB and TRD By German TÜV, incl. Cast Marking and Certificates EN 10204 3.1B, for Standard ITA
<b>D025</b>	Inspection And Pressure Testing acc. AD-Merkblatt, TRB and TRD By German TÜV, incl. Cast Marking and Certificates EN 10204 3.1B, for Special Constructed ITA
<b>D026</b>	Radiographic Examination Of Welds (Only Buttwelds) <b>acc. DIN 54111</b>
<b>D026.1</b>	Radiographic Examination Of Welds (Only Buttwelds) <b>acc. ASME Sec. VIII</b>
<b>D027</b>	Dyepenetrant Examination Of Welds acc. <b>EN473:2000</b> and <b>PED</b>
<b>D027.1</b>	Dyepenetrant Examination Of Welds acc. <b>ASME Sec. VIII</b>
<b>D028</b>	Härteprüfung nach NACE MR01-75, incl. NACE-Konformitätsbescheinigung (nur in Verbindung mit EN10204-3.1 Werkstoffbelegung)
<b>D029</b>	Weight Certificate (for all units of an order)
<b>D030</b>	PMI-Check
<b>D031</b>	Percentage of ferrite in welding

**Certificates for electrical components**

<b>Code</b>	<b>Description</b>
<b>D032</b>	Standard wiring plans and data sheets
<b>D033</b>	ATEX-certificates

**General notes for documentation**

**The standard documentation mentioned in our quotations and order acknowledgements consists of:**  
**1 off installation & operation manual (hard copy)**



Besides the products covered by this brochure, Intra-Automation GmbH also manufactures other high-quality and high precision instruments for industrial measurement tasks. For more information, please contact us (contact details on the backside of this brochure).

### Flow Measurement



Itabar®-Flow-Sensors

IntraSonic IS200 Ultrasonic Flow Meters

### Level Measurement

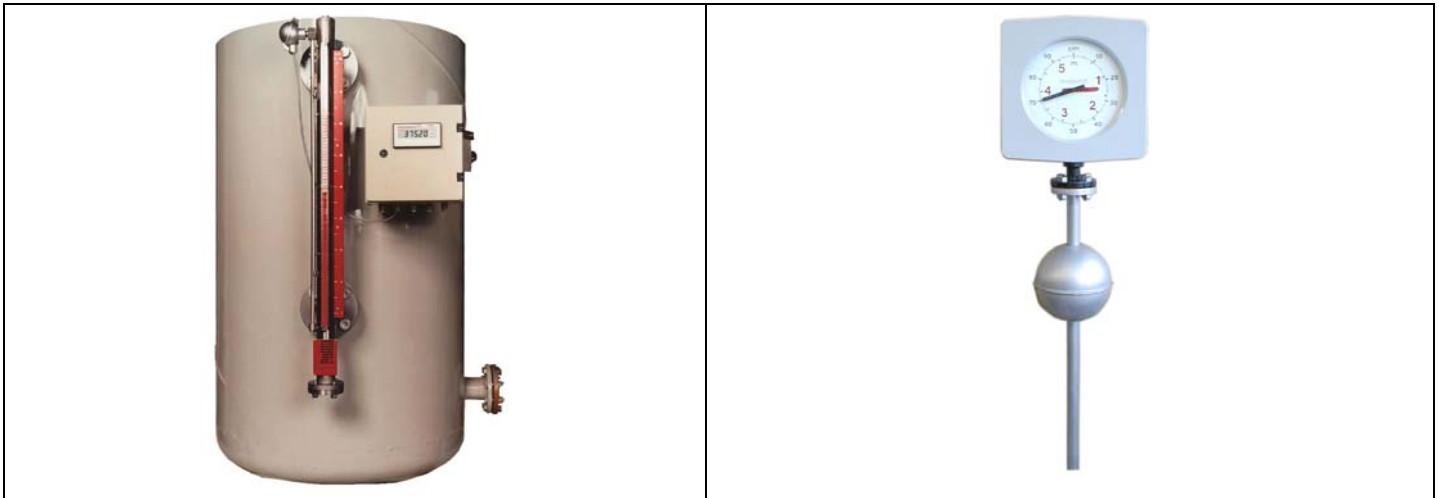

ITA-mag. level gauges

MAGLINK level indicators

### Other measurement tasks:



DigiFlow Flow and Level Computers

IntraCont digital Controllers

IntraDigit digital indicators



**Headquarters:**  
**(Germany, world-wide sales)**  
INTRA-AUTOMATION GmbH  
Otto-Hahn-Strasse 20  
41515 Grevenbroich  
GERMANY

☎ +49-(0)2181-75665-0  
☎ +49-(0)2181-64492  
✉ [info@intra-automation.de](mailto:info@intra-automation.de)  
💻 [www.intra-automation.de](http://www.intra-automation.de)

**Subsidiary in the Netherlands:**  
**(Sales in the Benelux-States)**  
BV INTRA-AUTOMATION HTP  
Bosschendijk 193  
4731 DD Oudenbosch  
THE NETHERLANDS

☎ +31-(0)165-32201  
☎ +31-(0)165-322970  
✉ [info@intra-automation.nl](mailto:info@intra-automation.nl)  
💻 [www.intra-automation.nl](http://www.intra-automation.nl)